

ACADEMIC JOURNAL OF HEALTH SCIENCES

MEDICINA BALEAR

Lower COVID-19 incidence in Bulgaria in 2022 can be attributed to the Delta variant's belated intense spread

Investigation of the Effect of Biochemical Parameters of Platelet-Rich Plasma on Sperm and Expression Levels of BAX, BCL₂ and Casp₉ Genes under Freezing Conditions

Prevalence of adverse drug effects of anti-retroviral drugs on HIV-positive patients receiving anti-retroviral treatment in General Hospital Onitsha, Anambra, Nigeria

Clinical characteristics in adult patients hospitalized for COVID-19 in a hospital in the Nuble region, Chile: descriptive cross-sectional study

Correlation between overweight and obesity scales and blood pressure values in 418.343 Spanish workers

Executive Functions Profiles in Preschool Children with Autism Spectrum Disorder

Gender-based evaluation of haematological and some inflammation markers in patients with mandibular fracture in a tertiary Hospital in southeast, Nigeria

Investigating the toxicity of germ of date seed on normal and cancerous cell line and P53 gene expression

The knowledge and attitudes of nursing students towards nosocomial infections in Morocco

Self-esteem as a protective agent of emotional exhaustion syndrome in teachers from Quito, Ecuador

Exploring biomedical waste management and disposal practices among hospitals in Port Harcourt, Rivers State

Colistin Resistance in Clinical Isolates of Acinetobacter baumannii by Broth Microdilution Method, Biofilm Production, and Antimicrobial Susceptibility Profiles: Experimental Study

Assessment of pubertal delay in adolescents with sickle cell anemia in two health facilities in Cameroon

Pathogenicity Testing of Microbial Isolates from Refuse Dumps sites and collection centres in Awka metropolis, Nigeria

Search for a clinical pattern for the prediction of pathological colonoscopy in patients participating in the first 2 rounds of the Colorectal Cancer Early Detection Program of the Hospital Comarcal de Inca

An epidemiological study of the prevalence and associated risk factors of goiter among adults in the southern part of Albania

The role of nurses in violence against healthcare professionals: a population-based study

Epidemiological profile of overload among paramedical staff at the regional hospital in southern Morocco

Comparison of the effect of different in-channel posts on the fracture resistance of simulated immature teeth

Vitamin D has no significant associations with high sensitivity C reactive protein and tumor necrosis factor-alpha in adults with prediabetes

COVID-19 Vaccination: Impact on Disease Severity and Mortality in an African Setting

Apollo's war against fevers: Rafael Rapó, Majorca (1707)

Bizarre parosteal osteochondromatous proliferation (Nora's lesion): A case with acute and painful presentation

Timely diagnosis of thyroid carcinoma in a young woman presenting to primary care during COVID-19 pandemic lockdown: from ultrasound to pathology

An unusual bite

ACADEMIC JOURNAL OF HEALTH SCIENCES

www.medicinabalear.org

Academic Journal of Health Sciences Medicina Balear is the organ of the **Royal Academy of Medicine of the Balearic Island**, It was created in 1986 with the aim of following up the scientific concerns and promoting the research spirit of health professionals in the Balearic Islands and with the additional objective of projecting health issues of interest to society.

Currently **Academic Journal of Health Sciences Medicina Balear** publishes in English, Spanish or Catalan original papers, review articles, letters to the editor and other writings of interest related to health sciences. The journal submits the originals to the anonymous review of at least two external experts (peer review).



The scientific material published in **AJHS Medicina Balear** is protected by copyright. **AJHS Medicina Balear** is not responsible for the information and opinions of the authors.

This work-unless otherwise indicated in the text, photographs, or other illustrations-is licensed under the Creative Commons NonCommercial-NoDerivativeWorks 3.0 Spain license.

Creative Commons; <http://creativecommons.org/licenses/by-nc-nd/3.0/es/>. In addition, the general public is authorized to reproduce, distribute and communicate the work provided that the authorship and the publishing entity are acknowledged and that no commercial use or derivative work is made.

Medicina Balear is included in the Digital Library of the Balearic Islands, of the University of the Balearic Islands, and is included in the following databases: Emerging Sources Citation Index (ESCI), Sherpa Romeo, Dulcinea, Latindex (catàleg), Dialnet, Índice Médico Español, DOAJ, Imbiomed, REDIB, Google Scholar and Journal Citation Indicator (JCI).



Biblioteca digital de les
Illes Balears



Universitat
de les Illes Balears



Clarivate
Analytics

WEB OF SCIENCE™

SHERPA
RoMEO

DOAJ
DIRECTORY OF
OPEN ACCESS
JOURNALS



DULCINEA
CONDICIONES DE AUTO-ARCHIVO DE
LAS REVISTAS CIENTÍFICAS ESPAÑOLAS

latindex IME

Índice
Médico
Español



Dialnet



CSIC
CONSEJO SUPERIOR DE INVESTIGACIONES CIENTÍFICAS

Google Scholar



EDIT

Royal Academy of Medicine of the Balearic Islands



www.ramib.org

Campaner, 4, 07003 Palma de Mallorca Tel. 971 72 12 30 Email: info@ramib.org

Pàgina web: <http://www.ramib.org>

Dipòsit Legal: PM 486 - 95

eISSN: 2255 - 0569

Design and layout

Intelagencia Publicitat - www.intelagencia.es - intelagencia@intelagencia.es

ACADEMIC JOURNAL OF HEALTH SCIENCES

Bimonthly journal of the Royal Academic of Medicine
of the Balearic Island

Editor A. Arturo López González, *RAMIB*,
Reial Acadèmia de Medicina de les Illes Balears (*RAMIB*)

EDITORIAL COUNCIL

Assistant manager Joan March Noguera, *RAMIB*
Secretary Sebastià Crespí Rotger, *RAMIB*
Editor-in -chief Pere Riutord Sbert, *RAMIB*
Vowels Javier Cortés Bordoy, *RAMIB*; Joan Benejam Gual, *RAMIB*;
Antonia Barceló Bennasar, *RAMIB*; Lluís Masmiquel Comas, *RAMIB*

SCIENTIFIC COUNCIL

Marta Couce Matovelle (*Case Western Reserve University*), José A. Guijarro Pastor (*AEMET*), Jaume Rosselló Mir (*Universitat de les Illes Balears*), Antoni Aguiló Pons (*Universitat de les Illes Balears*), Bartolomé Burguera González (*Cleveland Clinic - Ohio*), Amador Calafat Far (*Socidrogalcohol*), Valentín Esteban Buedo (*Conselleria de Sanitat, Generalitat Valenciana*), Carmen González Bosch (*Universitat de València*), Miguel A. Limon Pons (*Institut Menorquí d'Estudis*), Jordi Martínez Serra (*Hospital Son Espases*), Virgili Páez Cervi (*Bibliosalut*), Lucio Pallarés Ferreres (*Hospital Son Espases*), Ignacio Ricci Cabello (*University of Oxford*), Guillermo Sáez Tormo (*Universitat de València*), M^a Teófila Vicente Herrero (*IUNICS*), M^a José Anadón Baselga (*Universidad Complutense de Madrid*), Miquel Capó Martí (*Universidad Complutense de Madrid*), Antonio Coca Payeras (*Universitat de Barcelona*), James Drane (*Edinboro University*), Leopoldo Forner Navarro (*Universitat de València*), Alexandre García-Mas, (*Universitat de les Illes Balears*), Antoni Gelabert Mas (*Universitat Autònoma de Barcelona*), Joan Grimalt Obrador (*Consell Superior d'Investigacions Científiques, CSIC*), Federico Hawkins Carranza (*Universitat Complutense de Madrid*), Joan Carles March Cerdà (*Escuela Andaluza de Salud Pública, EASP*), Gabriel Martí Amengual (*Universitat de Barcelona*), Jasone Monasterio Aspiri (*Universitat Autònoma de Barcelona*) Rosa Pulgar Encinas (*Universidad de Granada*), Ciril Rozman (*Universitat de Barcelona*), Joan Benejam Gual (*Hospital de Manacor*), Joan Llobera Cànaves (*Atenció Primària - Mallorca*), José Reyes Moreno (*Hospital de Inca*), José María Vicens Colom (*Cercle d'Economia de Mallorca*), Carmen Tomás-Valiente Lanuza (*UIB*), Antonio Pareja Bezares (*Conselleria de Salut*), Farhad Safarpour Dehkordi (*Tehran University*), Anton Erkoreka Barrena (*Director del Museo Vasco de Historia de la Medicina y de la Ciencia*), José Ignacio Ramírez Manent (*Atención Primaria de Mallorca-Facultad de Medicina UIB*), Colwyn M. Jones (*European Association of Dental Public Health*), Pål Barkvoll (*Universitetet i Oslo*), Teresa Szupiany-Janecek (*Jagiellonian University Medical College Krakow*), Yarmukhamedov Bekhzod (*Tashkent University*), Dr. Pablo Arsenio López (*Director de LA PRENSA MÉDICA ARGENTINA*), Manuel Luis Martí (*Academia Nacional de Medicina de Buenos Aires*), Jesús Yasoda Endo Milán (*Universidad de Ciencias Médicas de Villa Clara. Cuba*), Manel Gené Badia (*Universidad de Barcelona*), Pedro Juan Tárraga López (*Universidad de Castilla la Mancha*), Natalia Tretiak (*Poltava Ukrainian Medical & Stomatological Academy*), Petro Tretiak Kravchuk (*Poltava Ukrainian Medical & Stomatological Academy*), Hans A Eguía (*Dansk Selskab for Almen Medicin-DSAM*), Erjona Abazaj (*Institute of Public Health of Albania*), Emmanuel Ifeanyi Obeagu (*Department of Medical Laboratory Science, Kampala International University, Uganda*), Mustafa Azizoğlu (*Dicle University, Turkey*).

With the
collaboration:



G CONSELLERIA
O PRESIDÈNCIA,
I FUNCIÓ PÚBLICA
B IGUALTAT

Fundació
Patronat Científic



Col·legi de Metges
Illes Balears



PREMIOS Y BECAS 2023

<https://www.comib.com/premios-y-becas-de-la-fundacio-patronat-cientific-del-comib-convocatoria-2023/>

PREMIOS DE INVESTIGACIÓN

La **Fundació Patronat Científic** convoca los Premios de Investigación **Mateu Orfila**, **Damià Carbó** y **Metge Matas** con la finalidad de **premiar la trayectoria de la investigación en Ciencias de la Salud** en nuestra comunidad.

PREMIO FUNDACIÓ MUTUAL MÈDICA AL MEJOR PROYECTO DE TESIS DOCTORAL

El premio tiene como finalidad **facilitar a los médicos colegiados** en las Illes Balears la **obtención del título de Doctor**. Con el patrocinio de la **Fundació Mutual Mèdica**.

BECAS FUNDACIÓ BANCO SABADELL DE ROTACIÓ EXTERNA PARA MÉDICOS RESIDENTES

Facilitar a los médicos que realicen la residencia en hospitales de Balears la **formación**, al menos durante un mes, en **centros hospitalarios nacionales y extranjeros**, en los dos últimos años de la residencia o al terminar la misma. Con la colaboración de la **Fundació Banc Sabadell**.

BECAS DE INNOVACIÓN

Tienen como objetivo facilitar a los médicos colegiados en las Illes Balears, excepto MIR, la **formación, durante al menos un mes, en centros sanitarios nacionales y extranjeros en técnicas diagnósticas o terapéuticas**.

CERTAMEN DE CASOS CLÍNICOS PARA MÉDICOS RESIDENTES

Premios a los mejores casos clínicos presentados por médicos residentes colegiados en Illes Balears de cualquier **especialidad médica o quirúrgica**.

PREMIO CAMILO JOSÉ CELA DE HUMANIDADES MÉDICAS

Premio literario de ámbito nacional destinado a **honrar la especial relación que tuvo el Nobel con los médicos** a lo largo de su vida.

ORIGINALS ARTICLES

- Lower COVID-19 incidence in Bulgaria in 2022 can be attributed to the Delta variant's belated intense spread** 9-16
Zhivka Getsova, Galin Kamenov, Nikolay Bogdanov, Vanya Rangelova
- Investigation of the Effect of Biochemical Parameters of Platelet-Rich Plasma on Sperm and Expression Levels of BAX, BCL₂, and Casp₉ Genes under Freezing Conditions** 17-26
Monireh Roomozi, Ramesh Monajemi, Kambiz Roshanaei, Masoud Tahvilidar
- Prevalence of adverse drug effects of anti-retroviral drugs on HIV-positive patients receiving anti-retroviral treatment in General Hospital Onitsha, Anambra, Nigeria** 27-36
Emmanuella Chidimma Ofoelo, David Chinaecherem Innocent, Ifeoma Lucy Ofoelo, Advait Vasavada, Stanley Chinedu Eneh
- Clinical characteristics in adult patients hospitalized for COVID-19 in a hospital in the Ñuble region, Chile: descriptive cross-sectional study** 37-43
Addí Rhode Navarro-Cruz, José M. Chavez-Montecinos, Javier Herrera-Fuentealba, Ashuin Kammar García, Gladys Quezada-Figueroa, Obdulia Vera-López, Martín Lazcano-Hernández, Orietta Segura-Badilla
- Correlation between overweight and obesity scales and blood pressure values in 418.343 Spanish workers** 44-51
Angel Arturo López-González, Pilar Tomás-Gil, Josep Lluís Coll Villalonga, Pau Martí- Lliteras, Hilda María González San Miguel, José Ignacio Ramírez-Manent
- Executive Functions Profiles in Preschool Children with Autism Spectrum Disorder** 52-58
Amela Pasalic, Haris Memisevic
- Gender-based evaluation of haematological and some inflammation markers in patients with mandibular fracture in a tertiary Hospital in southeast, Nigeria** 59-61
Emmanuel Ifeanyi Obeagu, Pilar Tomás-Gil, Josep Lluís Coll Villalonga, Pau Martí-Lliteras, Getrude Uzoma Obeagu
- Investigating the toxicity of germ of date seed on normal and cancerous cell line and P53 gene expression** 62-65
Abbasali Mokarrat-Yazdi BSc, Masoumeh Mazidi MD, Mohsen Ghiasi Tarzi MSc, Hadi Zare-Zardini PhD
- The knowledge and attitudes of nursing students towards nosocomial infections in Morocco** 66-72
Mohamed Amine Baba, Ahmed Kharbach, Abderrahmane Achbani, Aziz Naciri, Mohamed Nejmeddine
- Self-esteem as a protective agent of emotional exhaustion syndrome in teachers from Quito, Ecuador** 73-78
Darwin Raúl Noroña Salcedo, Vladimir Vega Falcón
- Exploring biomedical waste management and disposal practices among hospitals in Port Harcourt, Rivers State** 79-88
David Chinaecherem Innocent, Cosmas Nnadozie Ezejindu, Stanley Chinedu Eneh, Angelica Chinecherem Uwaezuoke, Valentine Nnachetam Unegbu, Advait Vasavada
- Colistin Resistance in Clinical Isolates of Acinetobacter baumannii by Broth Microdilution Method, Biofilm Production, and Antimicrobial Susceptibility Profiles: Experimental Study** 89-93
Anas M.J. Jamal Masalmeh, Emrah Güler, Kaya Süer, Meryem Güvenir
- Assessment of pubertal delay in adolescents with sickle cell anemia in two health facilities in Cameroon** 94-99
Andreas Chiabi, Ladwena Shuymuh, Cecilia Fomenky, Kate Kan, Denis Nsame
- Pathogenicity Testing of Microbial Isolates from Refuse Dumps sites and collection centres in Awka metropolis, Nigeria** 100-104
Chetachi Blessing Okwuanaso, Ifeoma. B. Enweani-Nwokelo, Emmanuel Ifeanyi Obeagu
- Search for a clinical pattern for the prediction of pathological colonoscopy in patients participating in the first 2 rounds of the Colorectal Cancer Early Detection Program of the Hospital Comarcal de Inca** 105-114
Marita Trelles, María del Pilar Roca, Jorge Sastre-Serra, Mónica Florido, Eduardo Iyo, Silvia Patricia Ortega, Miguel Angel Crespi, Carmen Sanchez-Contador, Elisa Miró, Guillem Artigues, José Reyes
- An epidemiological study of the prevalence and associated risk factors of goiter among adults in the southern part of Albania** 115-121
Igli Kokalari, Erjona Abazaj, Ela Aii
- The role of nurses in violence against healthcare professionals: a population-based study** 122-126
Selman Kizilkaya, Altuğ Çağatay
- Epidemiological profile of overload among paramedical staff at the regional hospital in southern Morocco** 127-131
Mohamed Boukrim, Majdoulina Obtel, Abderrahmane Achbani, Rachid Razine
- Comparison of the effect of different in-channel posts on the fracture resistance of simulated immature teeth** 132-136
Alp Şirman, Handan Ersev
- Vitamin D has no significant associations with high sensitivity C reactive protein and tumor necrosis factor-alpha in adults with prediabetes** 137-141
Ibrahim Faisal, Md Shahed Morshed, Tahniyah Haq, Shahjada Selim, Md Habibul Ghani, Muhammad Abul Hasanat, Md Fariduddin
- COVID-19 Vaccination: Impact on Disease Severity and Mortality in an African Setting** 142-147
Andreas Chiabi, Princewill Kum Unji, Alex Mambap Tatang, Samuel Angwafor, Loveline Lum Niba, Minette Jaqueline Adjii Porro, Denis Nsame Nforriwe
- SPECIAL ARTICLE**
- Apollo's war against fevers: Rafael Rapó, Majorca (1707)** 148-167
Antoni Contreras Màs
- CASE REPORT**
- Bizarre parosteal osteochondromatous proliferation (Nora's lesion): A case with acute and painful presentation** 168-170
Sayed Houssein Saeed-Banadaky
- Timely diagnosis of thyroid carcinoma in a young woman presenting to primary care during COVID-19 pandemic lockdown: from ultrasound to pathology** 171-174
Laura Hrehová, Kamal Mezian
- An unusual bite** 175-179
Juan Martínez-Andrés, Irene Ferrando-Fabra, Patricia Martínez-Andrés



¿Qué profesional puede tener 45 años de edad y 90 de experiencia?

La respuesta es Banca March

La experiencia de un profesional no está únicamente en su edad, sino también en la edad de la firma para la que trabaja.

Y 90 años de experiencia es lo que ofrecen los profesionales de Banca March.

90 años gestionando patrimonios y demostrando entre otras cosas, que la prudencia no está reñida con la rentabilidad.

 **BancaMarch**

ORIGINALES

- La menor incidencia de COVID-19 en Bulgaria en 2022 puede atribuirse a la intensa propagación tardía de la variante Delta** 9-16
Zhivka Getsova, Galin Kamenov, Nikolay Bogdanov, Vanya Rangelova
- Investigación del efecto de los parámetros bioquímicos del plasma rico en plaquetas en el esperma y los niveles de expresión de los genes BAX, BCL₂ y Casp₉ en condiciones de congelación de congelación** 17-26
Monireh Roomozi, Ramesh Monajemi, Kambiz Roshanaei, Masoud Tahvildar
- Prevalencia de los efectos adversos de los medicamentos antirretrovirales en pacientes seropositivos que reciben tratamiento antirretroviral en el Hospital General de Onitsha, Anambra, Nigeria** 27-36
Emmanuella Chidimma Ofoelo, David Chinaecherem Innocent, Ifeoma Lucy Ofoelo, Advait Vasavada, Stanley Chinedu Eneh
- Características clínicas en pacientes adultos hospitalizados por COVID-19 en un hospital de la región de Nuble, Chile: Estudio transversal descriptivo** 37-43
Addi Rhode Navarro-Cruz, José M. Chavez-Montecinos, Javier Herrera-Fuentealba, Ashuin Kammar García, Gladys Quezada-Figueroa, Obdulia Vera-López, Martín Lazcano-Hernández, Orietta Segura-Badilla
- Correlación entre las escalas de sobrepeso y obesidad y los valores de presión arterial en 418.343 trabajadores españoles** 44-51
Angel Arturo López-González, Pilar Tomás-Gil, Josep Lluís Coll Villalonga, Pau Martí- Lliteras, Hilda María González San Miguel, José Ignacio Ramírez-Manent
- Perfiles de funciones ejecutivas en niños preescolares con trastorno del espectro autista** 52-58
Amela Pasaic, Haris Memisevic
- Evaluación basada en el género de los marcadores hematológicos y de inflamación en pacientes con fractura mandibular en un Hospital terciario del sureste de Nigeria** 59-61
Emmanuel Ifeanyi Obeagu, Pilar Tomás-Gil, Josep Lluís Coll Villalonga, Pau Martí-Lliteras, Getrude Uzoma Obeagu
- Investigación de la toxicidad del germen de semilla de dátil en líneas celulares normales y cancerosas y expresión del gen P53** 62-65
Abbasali Mokarmat-Yazdi BSc, Masoumeh Mazidi MD, Mohsen Ghiasi Tarzi MSc, Hadi Zare-Zardini PhD
- Los conocimientos y las actitudes de los estudiantes de enfermería hacia las infecciones nosocomiales en Marruecos** 66-72
Mohamed Amine Baba, Ahmed Kharbach, Abderrahmane Achbani, Aziz Naciri, Mohamed Nejmeddine
- La autoestima como agente protector del síndrome de agotamiento emocional en docentes de Quito, Ecuador** 73-78
Darwin Raúl Noroña Salcedo, Vladimir Vega Falcón
- Exploración de las prácticas de gestión y eliminación de residuos biomédicos en los hospitales de Port Harcourt, Estado de Rivers** 79-88
David Chinaecherem Innocent, Cosmas Nnadozie Ezejindu, Stanley Chinedu Eneh, Angelica Chinecherem Uwaezuoke, Valentine Nnachetam Unegbu, Advait Vasavada
- Resistencia a la colistina en aislados clínicos de Acinetobacter baumannii por el método de microdilución en caldo, producción de biopelículas y perfiles de susceptibilidad a los antimicrobianos: Estudio experimental** 89-93
Anas M.J. Jamal Masalmeh, Emrah Güler, Kaya Sürer, Meryem Güvenir
- Evaluación del retraso puberal en adolescentes con anemia falciforme en dos centros de salud de Camerún** 94-99
Andreas Chiabi, Ladwena Shuymuh, Cecilia Fomenky, Kate Kan, Denis Nsame
- Pruebas de patogenicidad de aislados microbianos procedentes de vertederos y centros de recogida de basuras en la metrópoli de Awka, Nigeria** 100-104
Chetachi Blessing Okwuanaso, Ifeoma. B. Enweani-Nwokelo, Emmanuel Ifeanyi Obeagu
- Búsqueda de un patrón clínico para la predicción de colonoscopia patológica en los pacientes participantes de las 2 primeras rondas del Programa de Detección precoz de Cáncer Colorrectal del Hospital Comarcal de Inca** 105-114
Marita Trelles, María del Pilar Roca, Jorge Sastre-Serra, Mónica Florido, Eduardo Iyo, Silvia Patricia Ortega, Miguel Angel Crespi, Carmen Sanchez-Contador, Elisa Miró, Guillem Artigues, José Reyes
- Estudio epidemiológico sobre la prevalencia y los factores de riesgo asociados al bocio en adultos del sur de Albania** 115-121
Igli Kokalari, Erjona Abazaj, Ela Ali
- El papel de las enfermeras en la violencia contra los profesionales sanitarios: un estudio de base poblacional** 122-126
Selman Kizilkaya, Altuğ Çağatay
- Perfil epidemiológico de la sobrecarga entre el personal paramédico del hospital regional del sur de Marruecos** 127-131
Mohamed Boukrim, Majdouline Obtel, Abderrahmane Achbani, Rachid Razine
- Comparación del efecto de diferentes postes en canal sobre la resistencia a la fractura de dientes inmaduros simulados** 132-136
Alp Şirman, Handan Ersev
- La vitamina D no tiene asociaciones significativas con la proteína C reactiva de alta sensibilidad y el factor de necrosis tumoral alfa en adultos con prediabetes** 137-141
Ibrahim Faisal, Md Shahed Morshed, Tahniyah Haq, Shahjada Selim, Md Habibul Ghani, Muhammad Abul Hasanat, Md Fariduddin
- Vacunación COVID-19: Impacto en la gravedad y mortalidad de la enfermedad en un entorno africano** 142-147
Andreas Chiabi, Princewill Kum Unji, Alex Mambap Tatang, Samuel Angwafor, Loveline Lum Niba, Minette Jaqueline Adji Porro, Denis Nsame Nforiwe
- ARTÍCULO ESPECIAL**
- La guerra de Apolo contra las fiebres: Rafel Rapó, Mallorca (1707)** 148-167
Antoni Contreras Màs
- ESTUDIO DE CASOS**
- Proliferación osteocondromática parosteal extraña (lesión de Nora): Un caso de presentación aguda y dolorosa** 168-170
Seyyed Houssein Saeed-Banadaky
- Diagnóstico oportuno de carcinoma de tiroides en una mujer joven que acudió a atención primaria durante el confinamiento por la pandemia de COVID-19: de la ecografía a la patología** 171-174
Laura Hrehová, Kamal Mezian
- Una mordedura inusual** 175-179
Juan Martínez-Andrés, Irene Ferrando-Fabra, Patricia Martínez-Andrés

Haz algo grande por tu salud



#Duerme 1HoraMás

En Asisa somos expertos en salud y sabemos que el sueño es vital para el buen funcionamiento de tu corazón, tu cerebro y todo tu organismo.

Los especialistas determinan que **una persona adulta necesita entre 7 y 9 horas diarias de sueño** para estar bien.

Sin embargo, se estima que el 80% de los españoles duermen menos de este tiempo,

exponiéndose a **sufrir hipertensión, taquicardia, depresión, pérdida de memoria, sobrepeso y diabetes**, entre otros problemas. Y como sabes, **en Asisa solo nos preocupa tu salud. Por eso invertimos todos nuestros recursos en cuidarte**, incluido este anuncio en el que te aconsejamos que duermas una hora más todos los días.

Empresa Colaboradora:

**TR 200
AÑOS**

Asisa Palma de Mallorca.
C/ Pere Dezcallar i Net, 10
asisa.es 901 10 10 10

*Nada más que tu salud
Nada menos que tu salud*

asisa 

ORIGINAL

Lower COVID-19 incidence in Bulgaria in 2022 can be attributed to the Delta variant's belated intense spread

La menor incidencia de COVID-19 en Bulgaria en 2022 puede atribuirse a la intensa propagación tardía de la variante Delta

Zhivka Getsova¹ , Galin Kamenov¹, Nikolay Bogdanov¹ , Vanya Rangelova² 

1. National Centre of Infectious and Parasitic Diseases, Sofia, Bulgaria

2. Department of Epidemiology and Disaster Medicine, Medical University of Plovdiv, Bulgaria

Corresponding author

Vanya Rangelova

E-mail: vaniaran1238@gmail.com

Received: 2 - XII - 2022

Accepted: 3 - I - 2023

doi: 10.3306/AJHS.2023.38.03.9

Abstract

Objectives: The first COVID-19 wave caused case fatality rates (CFRs) of above 7% globally. In 2021 and 2022 the values of the same indicator went down to 2%. Differences between countries are still observed. The present study aimed to assess the CFRs dynamics in Bulgaria in relation to the specificity of the epidemic process in the country.

Methods: Descriptive analysis of cumulative incidence, mortality rates, and hospital admissions during the Delta and Omicron waves in Bulgaria and in the EU was performed. Differences in stringency index and testing capacities were analyzed to provide reasoning behind the findings. Indicator values were compared temporally and quantitatively.

Results: Data was reviewed for 27 EU countries. Opposing trends in Bulgaria and in the EU were reported. During the Delta wave incidence in Bulgaria was 25% higher than in the EU and increased by 67% during the Omicron period. In the EU, the increase during the Omicron wave was five-fold. Mortality in Bulgaria decreased by 38% between the two waves but it continued to be above the median mortality rate in the EU. Hospital admissions followed similar trends. Out of 16 countries only 5 experienced a drop in the number of new hospital patients. In Bulgaria, admissions shrank by 45% during the Omicron predominance.

Conclusions: Higher incidence during the Delta wave resulted in the accumulation of a population with recently obtained natural immunity. Given the evidence from countries with good vaccination coverage, it is reasonable to conclude that some of the mortality in Bulgaria could have been averted. Due to the observed positive association between acceptance of vaccines and other anti-epidemic measures, we recommend that future risk communication efforts highlight the importance of personal decision-making and social behaviour.

Keywords: COVID-19, Delta variant, Omicron variant, incidence, Bulgaria.

Resumen

Objetivos: La primera ola de COVID-19 provocó tasas de letalidad (CFR) superiores al 7% a nivel mundial. En 2021 y 2022 los valores del mismo indicador bajaron al 2%. Aún se observan diferencias entre países. El presente estudio tuvo como objetivo evaluar la dinámica de los CFR en Bulgaria en relación con la especificidad del proceso epidémico en el país.

Métodos: Se realizó un análisis descriptivo de la incidencia acumulada, las tasas de mortalidad y los ingresos hospitalarios durante las ondas Delta y Omicron en Bulgaria y en la UE. Se analizaron las diferencias en el índice de rigurosidad y las capacidades de prueba para proporcionar un razonamiento detrás de los hallazgos. Los valores de los indicadores se compararon temporal y cuantitativamente.

Resultados: Se revisaron los datos de 27 países de la UE. Encontramos tendencias opuestas en Bulgaria y en la UE. Durante la onda Delta, la incidencia en Bulgaria fue un 25 % más alta que en la UE, pero aumentó un 67 % durante el período Omicron. En la UE, el aumento fue del 576%. La mortalidad en Bulgaria disminuyó un 38 %, mientras que en la UE aumentó un 56 %. Los ingresos hospitalarios siguieron tendencias similares. De 16 países, solo 5 experimentaron una caída en el número de nuevos pacientes hospitalizados. En Bulgaria, las admisiones se redujeron en un 45% durante el predominio de Omicron.

Conclusiones: La mayor incidencia durante la onda Delta resultó en la acumulación de población con inmunidad natural recién obtenida. Dada la evidencia de países con buena cobertura de vacunación, es razonable concluir que parte de la mortalidad en Bulgaria podría haberse evitado. Debido a la asociación positiva observada entre la aceptación de las vacunas y otras medidas antiepidémicas, recomendamos que los futuros esfuerzos de comunicación de riesgos destaquen la importancia de la toma de decisiones personales y el comportamiento social.

Palabras clave: COVID-19, variante Delta, variante Omicron, incidencia, Bulgaria.

Introduction

In 2021 the COVID-19 case fatality rate (CFR) decreased substantially. While in 2020, the first wave caused CFR of above 7% globally, in 2021 and 2022 the values of the same indicator went down to 2%¹. However, differences between countries are still observed.

The main factors that drive CFR down refer to changes in the SIR (Susceptible, Infected, Removed (or Resistant)) structure of the population². Therefore, the immune response of the infected and the healthcare sector's capacity are related to the severity of the epidemiologic situation³. For instance, several studies confirm that some demographic determinants of the immune reaction related to patients' sex and age affect CFRs dynamics⁴⁻⁸. The natural course of the pandemic leading to accumulation of recovered population together with the social efforts for mass vaccination have also contributed to minimizing fatality outcomes.

Although CFR as a measurement implies some biases due to differences in testing strategies and case and death definitions adopted in different countries, we consider it important to provide an explanation for opposing trends in the dynamics of the indicator. Despite its values being highly dependent on testing rates (both of vaccinated and non-vaccinated populations)⁹⁻¹⁰, one of the reviewed studies concludes that testing percentage is not a driving factor for the different outcomes between the first and second wave of COVID-19 in Canada¹¹. The authors explain the decrease in CFRs with the higher incidence among the younger age groups after the first wave.

Nevertheless, with the introduction of the EU Digital Green Certificate in October 2021 in Bulgaria and the subsequent increase of performed tests for SARS-CoV-2, CFRs are believed to be less inaccurate as asymptomatic and mild infections were more likely to be registered.

The aim of the present study is to highlight the determining factors for the increasing fatality rates in Bulgaria in the period after July 2021 when the Delta variant became predominant, and the Omicron wave up to 1 May 2022.

Materials and methods

We chose for the subject of our analysis the epidemiologic situation in Bulgaria where CFRs are higher than the values from the region in the study period. A descriptive comparative analysis of cumulative incidence and mortality rates per 1 million for the conditional period of the Delta and Omicron waves in Bulgaria and in the EU was performed. The study compares the dynamics of biweekly incidence and total vaccine coverage temporally and quantitatively to explain changes in the share of immune population. Hospital admissions per million

were additionally compared in Bulgaria and in the EU to provide information of disease severity and overwhelming of the health sector that also pushes CFRs up.

To compare outcomes between the two waves periods of conditional variant predominance were analyzed. For the onset of the Delta wave 1 July was accepted as incidence in the EU started to grow approximately at that time¹. Co-circulation of Delta and Omicron makes the differentiation between the two waves a particular challenge. Given the ECDC's information that first local transmission within Europe has been registered on 2 December 2021¹² and the report on Omicron prevalence from the period between 20 December 2021 and 9 January 2022¹³, the onset of the Omicron wave was conditionally considered to be from 1 December 2021 for incidence rates. When analyzing mortality, we considered deaths registered from 15 July to 15 December 2021 as related to the Delta wave. This is due to time distance between symptoms onset and disease outcome. For the same reason, deaths caused by the Omicron variant are considered until 15 May 2022.

Along with the dynamics of incidence and mortality studied, we compared testing approaches as determinants of the recorded incidence. We also measured the average value of the stringency index regarding application of anti-epidemic measures for the period of Delta and Omicron per country to analyze whether incidence dynamics could be affected by the different measures imposed.

Publicly available sources were used for the analysis – the site "Our world in data" from where we have generated some of the graphs.

Ethical considerations

The study received an ethical exemption as it met one of the criteria for exemption (research that does not collect identifiable data).

Results

While most of the countries presented higher CFR in 2020 that decreased in time, in Bulgaria the indicator remained with no significant change. At the beginning of the pandemic, its values were drastically lower than the ones from the EU. The maximum cumulative value recorded in Bulgaria is from June 2020 - 6.05%, while in the EU during May 2020 the CFR surpassed 11%. While in the following few months CFRs decreased and met at slightly above 2%, after the fall of 2020 values in Bulgaria were gradually growing. The tendency was not observed in the region. For the second year of the pandemic, CFR in Bulgaria remained around 4% while the average value for the EU went down to 2%. Values of the indicator in Bulgaria went up with the peak of the Delta wave in November 2021.

Biweekly incidence dynamics show that the Delta wave started earlier in the EU but after the swell there was a long-lasting plateau (1500-2000 cases per 1M biweekly). A second increase was recorded in the region, starting mid-October, which merged with the Omicron wave. Biweekly incidence until the end of November in the EU was with the highest value of 7719 cases per million.

In Bulgaria, the cases started growing later with a steep increase from the beginning of October 2021. The peak was registered in the beginning of November when the new cases per million surpassed 9300 per 1M on a two-week basis. Therefore, during the Delta wave (1 July – 30 November 2021) the cumulative number of infections per million in Bulgaria (39974.63 cases per 1M) was substantially higher than in the EU (30067.68) (Table I). Total cumulative incidence in Bulgaria was higher by 25% compared to the EU.

Just as with Delta, there was a significant delay of the Omicron wave in Bulgaria. When Omicron gained ground, the number of new cases went several times up in the EU – from 7700 new cases per million on a biweekly basis in the end of November to 38000 during the Omicron predominance. In Bulgaria the raise was not so striking. The new cases per million during the Omicron wave there reached a peak of 17500 biweekly. Regarding cumulative values of incidence from the wave period starting 1 December 2021 to the end of the study period 30 April 2022, during the Omicron wave in Bulgaria there were recorded 66740.61 infections per million in comparison with 203283.74 in the EU (Table I).

Total cumulative incidence in Bulgaria was lower by 67% compared to the EU.

Cumulative mortality per million in the EU during both waves was substantially lower than in Bulgaria. The more severe Delta variant led to 1696.81 deaths per million in Bulgaria and 298.38 in the EU. Deaths during the Omicron wave increased with 56.48% in the EU (466.9 per 1M) and decreased with 38.4% in Bulgaria (1045.77 per 1M) but were still consistently higher than in the EU (Table II). With higher incidence and reduction in the number of deaths, CFR in Bulgaria went down from 4.14% on 15 December 2021 to 3.19% on 15 May 2022.

Hospitalizations in Bulgaria during both waves as well as during previous waves occurred much more often than elsewhere in the EU. Hospital admissions per million during the Omicron wave in Bulgaria decreased by almost half in comparison with the Delta period while in most EU countries with few exceptions they went up (Figure 1, Table III).

Regarding testing efforts, the total number of tests performed per 1000 in different countries varied between 237.412 and 9348.24 during the Delta wave (1 July – 30 November 2021) and between 445.042 and 8126.62 during the Omicron wave (1 December 2021 – 30 April 2022). In the first period of the study Bulgaria was placed in the second quarter (491.406 tests per 1000) compared with the other EU countries, while during the second period the country presented with the second lowest result (475.623 tests per 1000) (Figure 2).

Table I: Dynamics of COVID-19 cumulative incidence across the EU on dates marking conditional wave period¹.

Country	7/1/2021	12/1/2021	4/30/2022	Delta INC	Omicron INC	Waves Ratio
Romania	55918.44	92133.51	149720.21	36215.06	57586.70	1.59
Poland	75180.92	93170.16	156535.37	17989.24	63365.21	3.52
Bulgaria	61270.71	101245.33	167985.94	39974.63	66740.61	1.67
Hungary	83231.49	114756.39	195783.62	31524.90	81027.22	2.57
Malta	58143.55	75045.37	174164.88	16901.82	99119.50	5.86
Sweden	104188.68	115361.31	238931.29	11172.63	123569.98	11.06
Croatia	88660.85	151205.32	276458.54	62544.47	125253.22	2.00
Spain	80470.66	108971.45	250514.21	28500.79	141542.76	4.97
Finland	17378.10	34287.80	184793.08	16909.71	150505.28	8.90
Czechia	158640.92	206653.57	371534.00	48012.65	164880.43	3.43
Ireland	54704.22	115091.15	304242.27	60386.93	189151.12	3.13
Italy	71923.77	85138.28	277905.27	13214.51	192766.99	14.59
Belgium	93518.71	153852.33	349349.86	60333.62	195497.54	3.24
EU	73926.80	103994.48	307278.22	30067.68	203283.74	6.76
Germany	44708.04	70784.10	297448.93	26076.06	226664.83	8.69
Greece	40514.14	90479.84	318219.80	49965.70	227739.96	4.56
Lithuania	100186.21	170690.91	412679.23	70504.70	241988.32	3.43
Slovakia	142276.02	217078.57	464095.34	74802.55	247016.77	3.30
Estonia	98656.51	167961.79	430640.90	69305.28	262679.11	3.79
Slovenia	121429.08	199660.28	476575.09	78231.21	276914.80	3.54
Portugal	85714.01	111944.36	391413.38	26230.35	279469.02	10.65
Latvia	73375.64	135913.03	438659.84	62537.39	302746.81	4.84
Netherlands	96526.87	153660.94	460456.18	57134.06	306795.24	5.37
France	86328.66	115242.70	425667.69	28914.03	310425.00	10.74
Austria	72409.33	129568.64	467911.41	57159.31	338342.78	5.92
Cyprus	86346.42	150629.40	535955.63	64282.98	385326.23	5.99
Denmark	50245.98	84130.65	532375.68	33884.67	448245.03	13.23

Table II: Dynamics of COVID-19 cumulative mortality across the EU on dates marking conditional wave period¹.

Country	7/1/2021	12/1/2021	4/30/2022	Delta MORT	Omicron MORT	Waves Ratio
Romania	1771.73	2997.38	3394.56	1225.65	397.18	0.32
Poland	1962.82	2341.93	3033.51	379.11	691.58	1.82
Bulgaria	2637.72	4334.53	5380.30	1696.81	1045.77	0.62
Hungary	3091.01	3834.48	4772.81	743.48	938.33	1.26
Malta	797.35	894.17	1353.59	96.82	459.42	4.75
Sweden	1398.96	1454.18	1805.37	55.22	351.20	6.36
Croatia	2027.77	2901.14	3923.52	873.37	1022.38	1.17
Spain	1707.50	1866.18	2220.48	158.68	354.31	2.23
Finland	179.01	284.86	773.85	105.85	488.98	4.62
Czechia	2886.09	3312.13	3829.03	426.04	516.90	1.21
Ireland	1006.31	1170.15	1444.49	163.84	274.34	1.67
Italy	2157.99	2281.86	2789.38	123.87	507.53	4.10
Belgium	2170.97	2388.08	2722.58	217.11	334.50	1.54
EU	1662.20	1960.58	2427.48	298.38	466.90	1.56
Germany	1094.84	1279.01	1648.50	184.17	369.49	2.01
Greece	1227.24	1871.93	2828.72	644.69	956.79	1.48
Lithuania	1580.39	2530.64	3277.05	950.24	746.42	0.79
Slovakia	2298.99	2867.49	3678.85	568.51	811.36	1.43
Estonia	956.57	1406.64	1923.68	450.06	517.05	1.15
Slovenia	2087.85	2568.64	3124.45	480.79	555.82	1.16
Portugal	1670.25	1817.09	2194.63	146.84	377.55	2.57
Latvia	1356.52	2352.29	3094.05	995.78	741.76	0.74
Netherlands	1017.44	1161.60	1278.73	144.16	117.13	0.81
France	1653.17	1795.33	2185.40	142.16	390.07	2.74
Austria	1468.94	1831.64	2222.24	362.70	390.60	1.08
Cyprus	428.57	685.26	1172.98	256.70	487.72	1.90
Denmark	433.87	519.11	1073.92	85.24	554.81	6.51

Figure 1: Weekly hospital admissions within countries providing data for the selected indicator, measured in the end of the week - between 3 October 2021 and 24 April 2022. Starting period is selected according to the availability of data for Bulgaria^{1,15}.

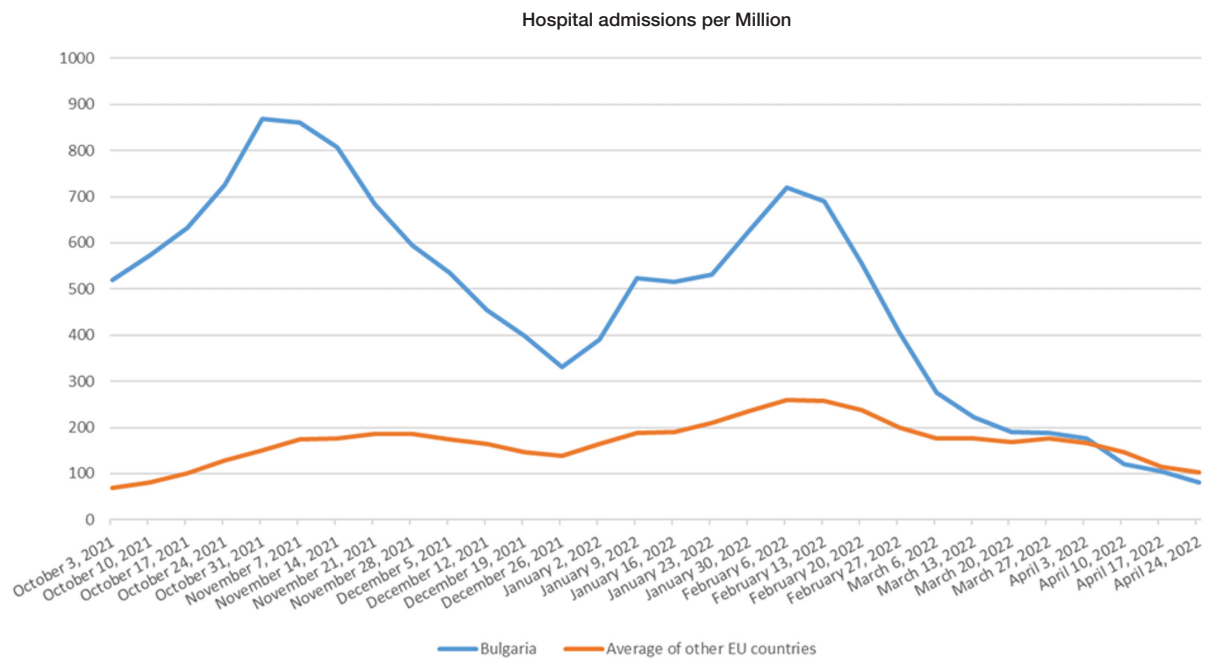
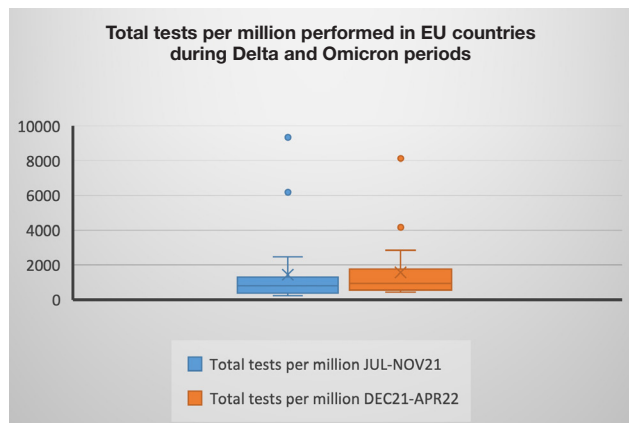

Table III: Average number of weekly hospital admissions for the periods 3 October 2021– 28 November 2021 (Delta wave) and 5 December 2021 – 24 April 2022 (Omicron wave). 1,15 Highlighted in red are values greater than the ones recorded in the country for the earlier period. Starting period is selected according to the availability of data for Bulgaria gathered through recordings from the COVID-19 Informational Portal.

PERIOD	Belgium	Bulgaria	Croatia	Czechia	Denmark	Estonia	France	Germany	Greece	Ireland	Italy	Latvia	Malta	Netherlands	Slovenia	Spain
OCT-NOV21	97.40	696.57	293.17	202.55	54.59	236.25	32.16	73.87	200.63	79.61	31.32	448.03	8.18	56.76	237.66	32.34
DEC21-APR22	131.92	382.77	242.78	237.15	249.81	227.92	169.88	107.11	250.79	153.21	109.16	341.04	100.11	71.54	171.04	143.86
RATIO OMICRON TO DELTA	1.35	0.55	0.83	1.17	4.58	0.96	5.28	1.45	1.25	1.92	3.49	0.76	12.24	1.26	0.72	4.45

Figure 2: Distribution of total tests performed in EU countries during the two 5-month periods – 1 July 2021 – 30 November 2021 (Delta) and 1 December 2021 – 30 April 2022 (Omicron). Values are obtained by subtracting measurements on respectively 1 July 2021 from the measurement on 30 November 2021 (total tests per 1 M during Delta) and on 30 November 2021 from the measurement on 1 May 2022 (total tests per 1M during Omicron)¹



In terms of imposed restrictions, we measured the average value of the stringency index calculated by Our World in Data for the two studied periods. Country scores during the Delta and Omicron periods ranged respectively as follows (26.87-68.86) and (20.63-63.10) (Figure 3). Results show that during both waves Bulgaria had similar averages of the indicator (39.85 during Delta and 36.95 during the Omicron wave) and ranked around the middle in both studied periods. The greatest release of measures was observed in Portugal where the indicator's value dropped by 23.11 units. Only two countries show higher average for the Omicron period – Estonia (stringency index increase with 8.98 units) and Slovakia (1.76 units).

Discussion

Differences in the incidence during the Delta wave could be related to differences in established immunity among populations. Although antibody effectiveness decreases with the emergence of new variants, vaccination remains the best means for prevention of infection^{16,17}. With a vaccinated population of less than 30%¹⁸ and assumable other 40% recovered from previous infection in Bulgaria¹⁹, in October 2021 there were supposedly 30% who remained susceptible. In contrast the average vaccination coverage in the EU at this time reached and surpassed 70% (Table III). Even if vaccination effectiveness against infection declines over time to around 22%²⁰, evidence suggest that COVID-19 incidence in Europe, which nevertheless increased, was suppressed by the obtained vaccination immunity. In contrast, low vaccination rates in Bulgaria did not allow the peak of new infections to be averted.

Interesting is the fact that the Omicron wave in Bulgaria presented with much lower infection rates than most of

Figure 3: Distribution of Average Stringency Index for the two studied wave periods¹

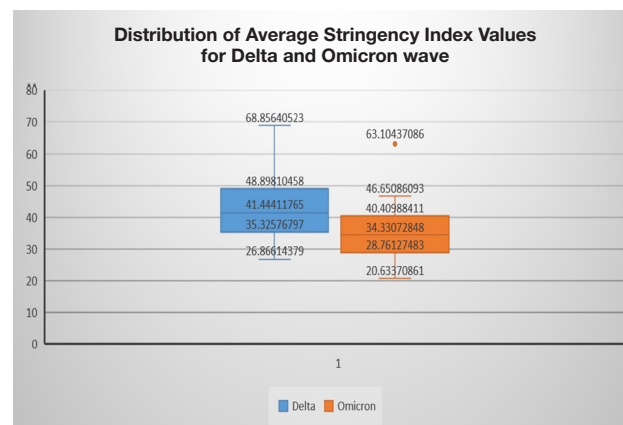

EU countries with the exception of Romania and Poland. A reason for this observation we find in the virtual delay of the Delta wave in the three countries and its intensive spread at a later stage demonstrated through large swells on the graph (Figure 4). However, intensive spread of Delta in Lithuania at approximately the same stage of the pandemic as Bulgaria, Romania and Poland did not suppressed the incidence growth levels in 2022.

Figure 4: Dynamics of COVID-19 incidence in EU, Bulgaria, Romania, Lithuania, and Poland¹

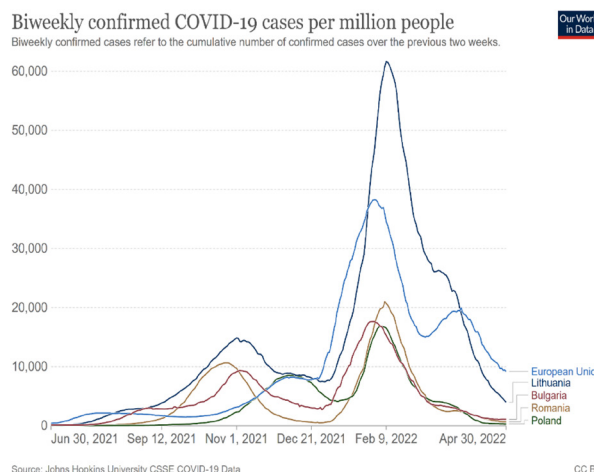

The more intensive spread of Delta and the short time window between the two waves in Romania, Poland and Bulgaria at the end of 2021 allowed for the accumulation of naturally immune population. In fact, the belated Delta wave in Poland reached its peak after the conditional onset of the Omicron wave that this study assumes²¹. Furthermore, we argue that the longer co-circulation of Delta and Omicron was an important determinant of the epidemiological situation in 2022. In our interpretation, we link the lower incidence rate during the Omicron predominance to the proximity between the fourth and

the fifth wave. While reports prove the latest variant's capacity to escape neutralizing antibodies especially time after infection or vaccination²², the Bulgarians, Romanians and Polish who recently recovered from Delta were relatively protected from contracting the new variant. In contrast, the rest of Europe may have experienced wane in immunity levels among recovered and vaccinated without a booster. The observed exception in Lithuania could be related to the considerably lower average stringency index (23.51).

A possible explanation for the observed higher values of COVID-19 mortality in Bulgaria in comparison with the rest of Europe in the second half of 2021 and the beginning of 2022 could be found again in mismatches in COVID-19 vaccine coverage. In general, a decrease in hospitalizations and deaths once vaccination was extended to cover the whole population was observed in the countries with good vaccination coverage²³⁻²⁷. In comparison, hospitalization rates in Bulgaria have not changed after the introduction of COVID-19 vaccines (**Figure 5**).

Figure 5: Number of COVID-19 patients in hospital per 1 M people¹.

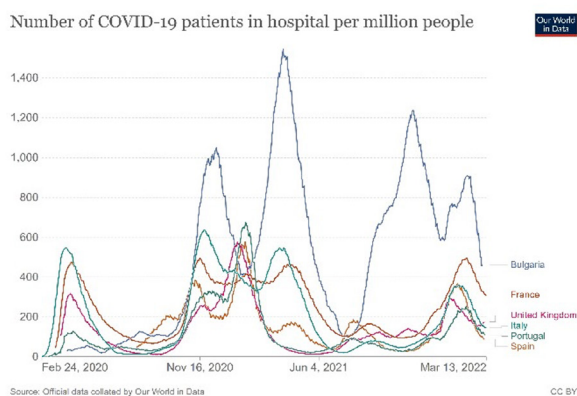

Given the higher incidence observed everywhere during the Omicron predominance, values of hospital admissions and mortality across Europe were bound to increase compared to the previous period. Reduction was only observed in Bulgaria, Croatia, Estonia, Latvia and Slovenia. Despite the steep swell in the incidence, with the increase in the numerator (number of cases), CFRs did not grow either in the rest of Europe.

The higher CFRs in Bulgaria could be explained with the low number of tests performed per 1000 as many of the infections may have gone unnoticed by the health system. However, values of weekly hospital admissions and cumulative deaths per 1M for both of the periods studied appear substantially higher in comparison with the rest of Europe. High numbers of hospital patients and fatal outcomes indicate an epidemic situation with greater severity. That is why despite biases, the CFRs are a useful indicator for intervention necessity in the case.

Observations regarding both incidence and mortality were made in an environment of varying social behaviors. Although most of the countries introduced almost identical anti-epidemic norms to control the virus, surveys show that deviations from mask wearing and social distance practice appeared at a different level around the EU²⁸. According to the collected data in the Covid Behaviors website, Bulgaria had one of the lowest degrees of population compliance. Provided the fact that vaccine acceptance correlates positively with anti-COVID measures compliance²⁹, it is difficult to ascertain whether the rapid spike in incidence in Bulgaria during the Delta wave was only due to low vaccination rates. However, since vaccine confidence and responsible social behavior are both determined by acceptance of measures, a recommendation of interventions consolidating COVID-19 social awareness and vaccination acceptance seem equally valid.

Another well-known factor that has a direct impact on COVID-19 is the resilience of the health system. Bulgaria is ranked first for mortality of cardiovascular diseases –cardiovascular death rate measures 424.688 (EU range 86.06– 424.688)¹. Patients with such conditions have been reported of higher risk for severe COVID-19 disease³⁰. Therefore, the bad general health of the Bulgarian population is an exacerbating factor and affects negatively CFR values causing them to soar. Existing pre-morbidity determines higher COVID-19 severity and therefore, results in higher hospitalization rates. During the pandemic bad general health dwindles the effect of interventions that were successful in countries with healthier population. Measuring the association between different health systems' performances and CFRs dynamics would be a subject of a prospective analysis.

Conclusion

In conclusion, we would like to highlight that the introduction of mass vaccination coincides with the reduction of hospitalizations and deaths in the countries with high vaccination coverage. Higher incidence during the Delta wave resulted in accumulation of population with recently obtained natural immunity. It is related to lower intensity of consequent Omicron wave in Bulgaria. However, reasons for the observed higher mortality in the country are complex and it is difficult to differentiate to what extent the exuberant number of deaths is related solely to low vaccination rates. Other factors such as health system resilience and population's general health are key confounders worth to study in prospective works. As limitations of our analysis we point out it does not consider other confounding factors that may be additionally pushing death rates up.

Given the evidence from countries with good vaccination coverage, it is reasonable to conclude that some of the

mortality in Bulgaria could have been averted if higher immunity was achieved through vaccines. Due to the observed positive association between acceptance of vaccines and other anti-epidemic measures, we recommend that future risk communication efforts highlight the importance of personal decision-making and social behavior. Persuasive communication should underline the benefits of collective responsibility. Increasing confidence in all measures will reduce pandemic burden related to incidence and mortality.

Conflicts of interest

None.

Funding

This work was funded by the European Fund for regional development through Operational Program Science and Education for Smart Growth 2014 - 2020, Grant BG05M2OP001-1.002-0001-C04 "Fundamental Translational and Clinical Investigations on Infections and Immunity".

References

- Mathieu E, Ritchie H, Rodés-Guirao L. Coronavirus Pandemic (COVID-19). Published online at OurWorldInData.org. Retrieved from: <https://ourworldindata.org/coronavirus> [Online Resource] Accessed 14.10.2022
- Qiu H, Wang Q, Wu Q, Zhou H. Does flattening the curve make a difference? An investigation of the COVID-19 pandemic based on an SIR model. *International Review of Economics & Finance*. 2022 Jul; 80: 159–65. <https://doi.org/10.1016/j.iref.2022.02.063>.
- Timelli L, Liuzzi G, Cannavacciuolo A, Petrosillo N, Puro V, Girardi E. Association of COVID-19 case fatality rate with disease burden: an ecological analysis in Italy during the first wave. *Int J Infect Dis*. 2021 Oct;111:186-189. <https://doi.org/10.1016/j.ijid.2021.08.032>.
- Tazerji SS, Shahabinejad F, Tokasi M, Rad MA, Khan MS, Safdar M, et al. Global data analysis and risk factors associated with morbidity and mortality of COVID-19. *Gene Rep*. 2022 Mar;26:101505. doi: 10.1016/j.genrep.2022.101505. Epub 2022 Jan 15. PMID: 35071820
- Chen Y, Klein SL, Garibaldi BT, Li H, Wu C, Osevala NM, et al. Aging in COVID-19: Vulnerability, immunity and intervention. *Ageing Res Rev*. 2021 Jan;65:101205., <https://doi.org/10.1016/j.ar.2020.101205>.
- Passarelli-Araujo H, Pott-Junior H, Susuki AM, Olak AS, Pescim RR, Tomimatsu MF, et al. The impact of COVID-19 vaccination on case fatality rates in a city in Southern Brazil. *American Journal of Infection Control* 2022; 50(5): 491-6.<https://doi.org/10.1016/j.ajic.2022.02.015>
- Cuschieri S, Grech, V. Protecting our vulnerable in the midst of the COVID-19 pandemic: lessons learnt from Malta. *Public Health* 2021; 198: 270-2., <https://doi.org/10.1016/j.puhe.2021.07.043>.
- Upadhyay AK, Shukla S. Correlation study to identify the factors affecting COVID-19 case fatality rates in India. *Diabetes & Metabolic Syndrome: Clinical Research & Reviews* 2021; 15(3): 993-9. <https://doi.org/10.1016/j.dsx.2021.04.025>.
- di Lego V, Sánchez-Romero M, Prskawetz A. The impact of COVID-19 vaccines on the Case Fatality Rate: The importance of monitoring breakthrough infections. *International Journal of Infectious Diseases* 2022; 119:178-83., <https://doi.org/10.1016/j.ijid.2022.03.059>.
- Lubis R, Satria FB, Zaki RA, Nurjazuli N, Hendrati LY. Factors influencing the COVID-19 pandemic situation in Indonesia, Malaysia and Taiwan in 2021. *Public Health in Practice* 2022; 4:100311. <https://doi.org/10.1016/j.puhp.2022.100311>.
- Hsu SH, Chang SH, Gross CP, Wang SY. Relative risks of COVID-19 fatality between the first and second waves of the pandemic in Ontario, Canada. *International Journal of Infectious Diseases* 2021; 109:189-91., <https://doi.org/10.1016/j.ijid.2021.06.059>.
- ECDC, Epidemiological update: Omicron variant of concern (VOC) – data as of 2 December 2021 (12.00), available at: <https://www.ecdc.europa.eu/en/news-events/epidemiological-update-omicron-variant-concern-voc-data-2-december-2021> Accessed 14.10.2022
- ECDC, Weekly epidemiological update: Omicron variant of concern (VOC) – week 2 (data as of 20 January 2022) EU/EEA, available at: <https://www.ecdc.europa.eu/en/news-events/weekly-epidemiological-update-omicron-variant-concern-voc-week-2-data-20-january-2022> Accessed 14.10.2022
- NCIPD, REFERENCE FOR SEQUENCING VARIANTS OF SARS-COV-2 AS OF 04.02.2022, Published on 04 February 2022 10:14, available at: https://www.ncipd.org/index.php?option=com_k2&view=item&id=673:ncov-sequencing-19012022&tmpl=component&print=1&lang=bg# Accessed 14.10.2022
- COVID-19 Information Portal <https://coronavirus.bg/> Accessed 14.10.2022
- Johnson AG. COVID-19 incidence and death rates among unvaccinated and fully vaccinated adults with and without booster doses during periods of Delta and Omicron variant emergence—25

- US Jurisdictions, April 4–December 25, 2021. *MMWR. Morbidity and mortality weekly report* 2022; 71. <http://dx.doi.org/10.15585/mmwr.mm7104e2>
17. Zheng C, Shao W, Chen X, Zhang B, Wang G, Zhang W. Real-world effectiveness of COVID-19 vaccines: a literature review and meta-analysis. *International Journal of Infectious Diseases* 2022; 114:252-60. <https://doi.org/10.1016/j.ijid.2021.11.009>
18. ECDC, COVID-19 Vaccine Tracker, available at: <https://vaccinetracker.ecdc.europa.eu/public/extensions/COVID-19/vaccine-tracker.html#uptake-tab> Accessed 14.10.2022
19. COVID-19 Information Portal, „Collective immunity levels will be clear in a month”, 21.06.2021, available at: <https://coronavirus.bg/bg/news/2013> Accessed 14.10.2022
20. Ssentongo P, Ssentongo AE, Voleti N, Groff D, Sun A, Ba DM, Nunez J, Parent LJ, Chinchilli VM, Paules CI. SARS-CoV-2 vaccine effectiveness against infection, symptomatic and severe COVID-19: a systematic review and meta-analysis. *BMC Infect Dis.* 2022 May 7;22(1):439. doi: 10.1186/s12879-022-07418-y.
21. Emma B. Hodcroft. 2021. “CoVariants: SARS-CoV-2 Mutations and Variants of Interest.” <https://covariants.org/> Accessed 14.10.2022
22. Cao Y, Wang J, Jian F, Xiao T. Credenciamento ESIB. *Nature* 2022; 602(7898):657-63.
23. Nguyen LBL, Bauer R, Lesieur Z, Galtier F, Duval X, Vanhems P, et al. Vaccine effectiveness against COVID-19 hospitalization in adults in France: A test negative case control study. *Infectious Diseases Now* 2022; 52(1): 40-3. <https://doi.org/10.1016/j.idnow.2021.12.002>
24. Zheng C, Shao W, Chen X, Zhang B, Wang G, Zhang W. Real-world effectiveness of COVID-19 vaccines: a literature review and meta-analysis. *International Journal of Infectious Diseases* 2022; 114:252-60. <https://doi.org/10.1016/j.ijid.2021.11.009>
25. Mallah N, Pardo-Seco J, López-Pérez LR, González-Pérez JM, Rosón B, Otero-Barrós MT, et al. Effectiveness of COVID-19 vaccine booster in the general population and in subjects with comorbidities. A population-based study in Spain. *Environmental Research* 2022; 215: 114252. <https://doi.org/10.1016/j.enres.2022.114252>.
26. Meslé MM, Brown J, Mook P, Hagan J, Pastore R, Bundle N, et al. Estimated number of deaths directly averted in people 60 years and older as a result of COVID-19 vaccination in the WHO European Region, December 2020 to November 2021. *Eurosurveillance* 2022; 26(47):2101021. <https://doi.org/10.2807/1560-7917.ES.2021.26.47.2101021>
27. Reno C, Sanmarchi F, Stoto MA, Fantini MP, Lenzi J, Golinelli, D. The impact of health policies and vaccine rollout on the COVID-19 pandemic waves in Italy. *Health policy and technology* 2022; 100604. <https://doi.org/10.1016/j.hlpt.2022.100604>.
28. Babalola S, Krenn S, Rosen JG, Serlemitsos E, Shaivitz M, Storey D, et al. COVID Behaviors Dashboard. Johns Hopkins Center for Communication Programs in collaboration with Facebook Data for Good, Delphi Group at Carnegie Mellon University, University of Maryland Social Data Science Center, Global Outbreak Alert and Response Network. Published September 2021. Available at: <https://covidbehaviors.org>. Accessed 14.10.2022
29. Wake AD. The willingness to receive COVID-19 vaccine and its associated factors: “vaccination refusal could prolong the war of this pandemic”—a systematic review. *Risk management and healthcare policy* 2021; 14: 2609. <https://doi.org/10.2147/RMHP.S311074>
30. Sharma, AK, Baig VN, Sharma S, Dalela G, Panwar RB, Katoch VM, et al. Cardiovascular risk factors and outcomes in COVID-19: A hospital-based study in India. *PLOS Global Public Health* 2022; 2(4):e0000234. <https://doi.org/10.1371/journal.pgph.0000234>

ORIGINAL

Investigation of the Effect of Biochemical Parameters of Platelet-Rich Plasma on Sperm and Expression Levels of BAX, BCL₂ and Casp₉ Genes under Freezing Conditions

Investigación del efecto de los parámetros bioquímicos del plasma rico en plaquetas en el espermatozoos y los niveles de expresión de los genes BAX, BCL₂ y Casp₉ en condiciones de congelación

Monireh Roomozi¹ , Ramesh Monajemi¹ , Kambiz Roshanaei² , Masoud Tahvildar³ 

1. Department of Biology, Falavarjan Branch, Islamic Azad University, Isfahan, Iran

2. Department of Urology, Qom Branch, Islamic Azad University, Qom, Iran

3. Department of Biology, Falavarjan Branch, Islamic Azad University, Isfahan, Iran

Corresponding author

Ramesh Monajemi

E-mail: monajemi@iaufala.ac.ir

Received: 5 - XII - 2022

Accepted: 5 - I - 2023

doi: 10.3306/AJHS.2023.38.03.17

Abstract

Objectives: Cryopreservation of spermatozoa is an important technique to help fertility. To improve semen freezing protocols, various compounds are used today to protect spermatozoa against damages. The purpose of this study is to examine the effect of platelet rich plasma on the quality of sperm parameters, oxidative stress level and chromatin health and to assess the expression level of BAX, BCL2 and Caspase9 genes in the frozen sperm cells.

Methods: In this study, 40 normal semen samples were collected from patients who referred to the Fertility Research Center of Jahad Daneshgahi in Qom. These samples were frozen in different concentrations of platelet-rich plasma of 2.5, 5, 10, 20 and 25% by fast freezing and stored in liquid Nitrogen for 14 days. Sperm parameters were analyzed before and after freezing according to WHO 2010 protocol. To determine the optimal dose and study the effect of the intended platelet-rich plasma more accurately, complementary tests of DNA fragmentation using SDFa, and evaluation of the expression level of BAX, BCL2 and Caspase9 genes using Real-time PCR were conducted. The data was finally analyzed using one-way analysis of variance and post hoc-Tukey test.

Results: Study results show that concentrations of 5 and 10 %, as the best doses of platelet-rich plasma in the freezing process, significantly protect the parameters of motility, viability and morphology of the sperm; they also cause significant decrease in DNA fragmentation due to freezing ($p < 0.05$). Gene expression results shows that optimal dose of platelet-rich plasma increases the expression level of BAX, BCL2 and Caspase9 genes ($p < 0.05$) and the ratio of BAX/BCL2 shows a significant increase as well.

Conclusion: Results of this study show that appropriate dose of platelet-rich plasma can positively influence the frozen-thawed sperm and significantly protect the sperm against freezing damages.

Keywords: Infertility, Cryopreservation, Platelet-Rich Plasma, Apoptosis.

Resumen

Objetivos: La criopreservación de espermatozoides es una técnica importante para ayudar a la fertilidad. Para mejorar los protocolos de congelación de semen, hoy en día se utilizan varios compuestos para proteger a los espermatozoides contra daños. El propósito de este estudio es examinar el efecto del plasma rico en plaquetas sobre la calidad de los parámetros del espermatozoos, el nivel de estrés oxidativo y la salud de la cromatina y evaluar el nivel de expresión de los genes BAX, BCL2 y Caspase9 en los espermatozoides congelados.

Métodos: En este estudio, se recolectaron 40 muestras de semen normales de pacientes que se derivaron al Centro de Investigación de Fertilidad de Jahad Daneshgahi en Qom. Estas muestras fueron congeladas en diferentes concentraciones de plasma rico en plaquetas al 2,5, 5, 10, 20 y 25% por congelación rápida y almacenadas en Nitrógeno líquido durante 14 días. Los parámetros espermáticos se analizaron antes y después de la congelación según el protocolo de la OMS de 2010. Para determinar la dosis óptima y estudiar con mayor precisión el efecto del plasma rico en plaquetas deseado, se realizaron pruebas complementarias de fragmentación de ADN mediante SDFa y evaluación del nivel de expresión de los genes BAX, BCL2 y Caspase9 mediante PCR en tiempo real. Finalmente, los datos se analizaron mediante el análisis de varianza de una vía y la prueba post hoc de Tukey.

Resultados: Los resultados del estudio muestran que concentraciones de 5 y 10%, como las mejores dosis de plasma rico en plaquetas en el proceso de congelación, protegen significativamente los parámetros de motilidad, viabilidad y morfología de los espermatozoides; también provocan una disminución significativa de la fragmentación del ADN por congelación ($p < 0,05$). Los resultados de la expresión génica muestran que la dosis óptima de plasma rico en plaquetas aumenta el nivel de expresión de los genes BAX, BCL2 y Caspase9 ($p < 0,05$) y la proporción de BAX/BCL2 también muestra un aumento significativo.

Conclusión: Los resultados de este estudio muestran que la dosis adecuada de plasma rico en plaquetas puede influir positivamente en el espermatozoos congelado-descongelado y protegerlo significativamente contra daños por congelación.

Palabras clave: Infertilidad, Criopreservación, Plasma Rico en Plaquetas, Apoptosis.

Introduction

Despite a lot of efforts made to know the biology of freezing using various methods, it still causes overgeneration of Reactive Oxygen Species (ROS) and development of oxidative stress through exerting chemical and physical pressure on the sperm membrane. Under physiological conditions, spermatozoa produce a little ROS which is required for capacitation and acrosome reaction. When ROSs and RNSs are over-generated, biological deterioration called oxidative stress and nitrate stress occurs; these, in turn, influence the membrane structure and deteriorate the selective permeability of the sperm membrane and finally lead to cell death¹.

A platelet-rich extract consisting of various components is recently employed which has the following functions:

- Removing ROSs such as Hydroxyl radical and singlet oxygen and RNSs such as peroxy nitrite and Nitric oxide;
- Revitalizing external and internal oxidants such as Vitamin E, Vitamin C, catalase and glutathione reductase;
- Improving the capacitation of antioxidants such as superoxide dismutase, glutamate oxaloacetate transaminase, catalase and lactate dehydrogenase;
- Forming a strong shield in the sperm cell membrane against free radical attacks².

Cryopreservation of sperm is initial exposure of sperm to cryoprotectants, lowering the temperature below 0°C, storing, melting and, finally, removing the cryoprotectant and returning to the natural physiological state. Freezing human sperm is widely used in in vitro fertilization (IVF) plans under laboratory conditions to preserve the male gamete and provide a chance for subsequent fertilization. About 10-15% of couples are seeking infertility treatment and childbearing throughout the world; and 50% of these infertile couples have sperm-related problems. Sperm banking is used for several purposes: men whose fertility power is influenced by vasectomy, treatment with cytotoxic agents or by radiotherapy as well as men who are at the risk of sperm damage because of their working conditions³. Sperm freezing banks may also be used to store semen samples to be used in the following cases:

1. Infertility cases where a man cannot produce enough and adequate sperm to use ART.
2. Collecting semen is impossible on the day of obtaining the eggs for any reason.
3. Men with Azoospermia whose sperm is obtained through surgical techniques. However, sperm stored at low temperatures is less fertile than the fresh sperm. In the freezing process, the temperature of cells or the whole tissue is lowered to below 0°C and this temperature is usually 196°C below zero and the freezing occurs using Liquid Nitrogen (LN2)⁴. Long-term sperm storage is

accomplished through controlling intracellular metabolism; in fact, no biochemical activity occurs below -196°C which results from lack of sufficient thermal energy required for chemical reactions at this temperature. Moreover, there is no fluid required for such a metabolic activity. However, the tissue of living cells might be damaged during the freeze-thawing process. Negative effects of freezing on sperm function are: decline in motility, viability, chromatin structure, the sperm plasma membrane, fertilization ability, preliminary fetal growth, implantation and, finally, reduced pregnancy chance⁵.

Since sperm cells have inadequate antioxidants in their cytoplasm, they are more vulnerable to damages caused by freezing which may lead to impaired function due to molecular changes made in the membrane structure and sperm genome. Apoptosis is another mechanism that threatens the sperm health during the freezing. Survival of the cell after freezing is not only associated with potential damages resulting from the freezing process, but it also depends on the thawing process. Studies show that there is a negative correlation between ROS production and sperm morphology. Teratozoospermic samples with high percentage of Cytoplasmic droplets produce higher amounts of ROS which results from active cytoplasmic enzyme of Glucose 6 phosphate dehydrogenase (G6PD) that produces NADPH and increases ROS production. Lipid peroxidation is a well-known and harmful process because of making changes in lipid arrangement of the sperm membrane and decreasing the sperm motility. Lipid peroxidation control is applied on the reproductive process by antioxidant molecules and protective enzymes within the sperm and seminal plasma. Seminal plasma contains enzymes such as Superoxide dismutase (SOD), Glutathione peroxidase (GPX and Cat) which play a significant role in inhibiting the damaging effects of ROS. Lipid peroxidation reduces the sperm motility which may result from imbalance in the activities of SOD, GPX and CAT in the seminal plasma or lack of total Antioxidant Capacity of the cell. These enzymes are antioxidants that restrain Lipid peroxidation. Therefore, oxidative damage is not only associated with ROS production but it also depends on sperm antioxidant system and seminal plasma^{6&7}.

On the other hand, some studies show that there is no significant correlation between antioxidants and thawed semen fertility after freezing. Considering the damaging effect of freezing, we used the platelet-rich plasma to see its effects on protecting vital parameters and molecular structure of sperm under freezing conditions and evaluate the Bax, BCL₂ and casp₉ gene expression levels in the presence of the platelet-rich extract in the freezing process.

Sperm parameters

Sperm motility: In semen analysis, progressive motility of sperm is measured by calculating the rapid movement (a) plus slow movement (b). Total number

of the mobile sperm is measured by calculating both progressive and non-progressive motility. WHO and most laboratories assume 50% as the normal low sperm motility. However, Fertilizer Association considers 40% motility as a criterion for male factor infertility. Therefore, the normal low level indicates significant changes and depends on the regional laboratory experience. Generally, men who have greater than 10 million motile sperm per milliliter (ml) of semen enjoy a higher fertility chance than men who have 2-10 million sperm/ml. Sperm motility is induced by the wave motion of sperm flagellum which results from the conversion of ATP biochemical energy into Kinetic Energy and this causes microtubules in flagella slide along each other. Abnormalities in various components of flagellum in human spermatozoa can cause defects in sperm motility, which are classified based on defects in axoneme or preaxoneme structure. It seems that spermatozoa need to pass through cervical mucus and penetrate the transparent outer layer of the egg^{88,9}.

Materials and methods

Before the experiment, a vial containing Agarose was placed in a bain-marie boiling at 100°C for 5 minutes. The resulting solution was transferred to 0.5 ml microtubes with a volume of 100 µl and stored at 2-8°C.

Material and solutions used in this experiment include:

- 0.5 ml microtube
- Denaturing solution A
- Lysing solution B
- Staining solution C
- Staining solution D
- Staining solution E
- 96° alcohol
- Treated slide

After microscopic evaluation, semen spermatozoa are washed twice in HamsF-10. To do this, 500 λ of semen sample is poured into the test tube; 1.5 ml HamsF-10 is added to it and centrifuged (200 g for 5 minutes). Finally, a suspension with 15-20 million spermatozoa is prepared. One of the 0.5 ml microtubes containing Agarose is placed in 100°C bain-marie for 5 minutes

so that Agarose is thawed well. Then it is put in 37°C bain-marie. 30 µl of the sperm suspension is added to the microtube containing Agarose and mixed by turning it up-down. 30 λ of the above mixture is placed on the slide over the center of the hole S and a coverslip is placed on top; press it briefly to avoid the formation of air bubbles. All through the process, the slide should be placed horizontally. The slide should immediately be transferred on a cold surface (metal or glass surface) and stored in the fridge for 5 minutes. Then the slide is taken out from the fridge and the coverslip is slowly removed from the hole S. The slide is placed in a box horizontally and denaturing solution A is poured into the hole to fill up. After 7-minute incubation at room temperature in dark, the slide is tilted to remove the excess solution from the hole. Then the lysing solution B is poured on the hole and incubated for 15 minutes at room temperature in a biological safety cabinet. After 15 minutes, the solution is removed from the slide and the hole is washed with distilled water for 2 minutes. The slide is tilted again to fully remove the distilled water from the hole and immersed in increasing percentages of ethanol for dehydration (70, 90, 100% ethanol, each for 2 minutes). Ethanol is removed from the slide and the slide is placed on the staining dish. To stain the slide and view the aura around the sperm head, staining solution C is poured on the hole and the slide is incubated at room temperature for 75 seconds. Then it is tilted and the staining solution D is poured on the hole and the slide is incubated at room temperature for 3 minutes. Finally, the staining solution E is poured on the hole and the slide is incubated at room temperature for 2 minutes. Like previous stages, remove the solutions from the hole S and wash it in water. Then place the slide in tilted form to air dry at room temperature. View the slide with 100x lens. First, obtain the image with a 40x lens and then measure the aura diameter with 100x (oil immersion) magnification. In this stage, at least 200 perfect sperm (including both head and tail) should be counted and the percentage of the number of the sperm with and without aura should be reported.

Research Implementation Method

Location of experiments: This study was conducted in the Fertility Research Center of Jahad Daneshgahi and Azad University of Qom.

Table 1: List of the required tools and instruments.

Instrument	Brand	Manufacturing country	Seller company
Optical microscope	Olympus	Japan	Tehran Jarah Novin
Fluorescence microscope	EURO Star	Germany	Nima Pouyesh Teb
37°C Incubator	Pars Azma	Iran	Pars Azma
Cell counter	Labtron	Iran	Behdad
Centrifuge	Hitech	Germany	Faradid Adak Gostaran
Laminar Flow Hood	Besat	Iran	Besat Iran
Thermal Cycler	----	Poland	ParaMed
Real-time PCR	Corbett	Australia	ParaMed
Microcentrifuge	Kiagene	Germany	Tajhizyar
Spectrophotometer	Photometer 5010	Germany	Farasamed

Research methodology

This is a case-control laboratory study where samples were selected among men aged 30-40 years old by an approved urologist between 2020-2021. Men with varicoceles, men who had a prior history of varicocele surgery, men who suffered from a systemic disease or were taking medication for such a disease, men with a prior history of Chemotherapy or Radiotherapy, anatomical problems in genital organs including testicular atrophy, low sperm count (oligospermia) or azoospermia, men on treatment with antiandrogen or androgen or testosterone, with aromatase inhibitors or anti estrogen drugs, or antidepressants were excluded from the study.

Discussion

Seminal fluid collection: Subjects were asked to avoid intercourse for 3-4 days and then they were given a sterile and graduated container to collect their semen sample. The collected samples were stored in the 37°C Incubator for 20 minutes to get liquefied. After common evaluation based on WHO 2010 criteria, individuals' semen samples went through the laboratory processes.

Evaluation or analysis of sperm parameters: The analysis was conducted in two levels: macroscopic (appearance, liquefaction, volume, and pH) and microscopic level (sperm count, sperm motility, sperm morphology).

Microscopic tests: By microscope examination of semen, density, count, motility, morphological abnormalities, agglutination and viability of the sperm were studied. Although ordinary optical microscope is usually used to assess non-stained semen, Phase Contrast Microscope can be used for fresh and non-stained or washed semen sample for more accurate analysis. 10µl of the sample is first drawn on the slide by a sampler. Then it is covered by a 22 × 22 mm coverslip. Before viewing the sample, wait a minute until the sample is stabilized. This can be conducted at room temperature but the temperature should be 20-25°C. Very different number of spermatozoa in various fields indicates non-uniformity of the sample. Therefore, samples should be mixed again. Non-uniformity implies the presence of mucus, abnormal viscosity, abnormal dissolution and agglutination of the sperm which should be reported¹⁰.

Sperm motility: Sperm motility is one of the most important factors to determine the potential fertility of individuals and the pregnancy rate in fertility centers is estimated based on the percentage of the progressive motility of an individual's specimen. While in andrology labs, the motility rate is calculated in two ways: by eye using the microscope or by the computer software (CASA); accurate assessment of sperm motility should be conducted at least 30 minutes to one hour after ejaculation

and once the sample is liquefied. As time passes, the report would not be accurate owing to dehydration as well as PH and temperature changes. Sperm motility assessment should be conducted at the temperature of 37 °C or at room temperature¹⁰. First, a smear was made from sperm cell suspension. If the cell density is lower than 106×20 /ml of semen fluid, a drop of 10-20 µl is used; if it is greater than 106×20 /ml of semen fluid, a drop of 5-8 µl is used. Leave the drop in the middle of one end of the slide. Place the edge of the second slide at a 30-degree angle at the drop so that the sperm drop is spread in the width of the first slide. Hold the two slides firmly; draw the second slide slowly towards yourself; then, push the slide slowly forward along the first slide. This is known as the best technique (Figure 1).

Figure 1: Making smear for staining.

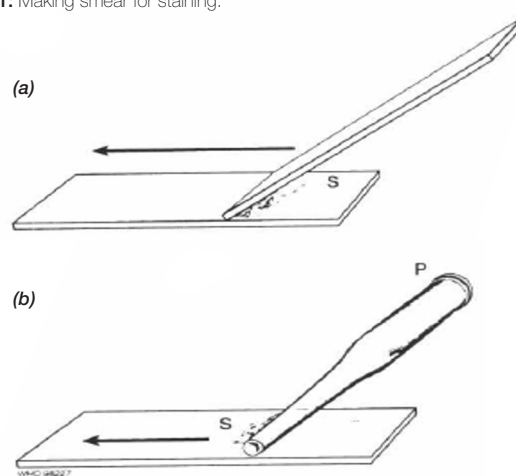
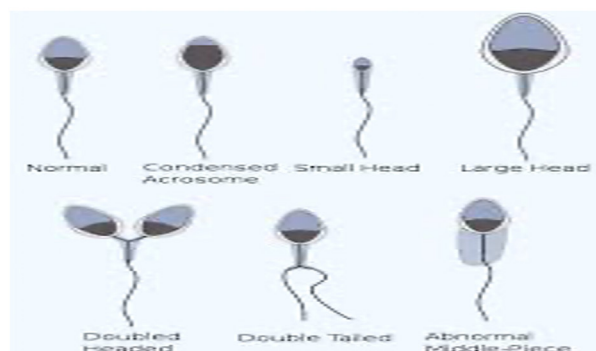

Figure 2: Normal sperm and various related abnormalities.



Sperm vitality assessment: Sperm vitality in semen sample is determined by the number of the live sperm. This assessment is recommended for semen fluid sample with the sperm having progressive motility less than 40%. This technique is based on differentiating the live from dead sperm by Eosin-nigrosin staining. Live cells become red by applying Eosin and Nigrosin provides a dark background in slide for easier assessment. This test was performed using Vitality Assay Kit (Dayan Zist Azma-Iran) which contains solution A and B.

Figure 3: Eosin-nigrosin staining to test sperm viability.



After sample analysis, the sperm is centrifuged and a volume of 2 ml is prepared; it is then divided into four equal parts. One part is frozen only by the freezing solution and the remaining three parts are frozen with different concentrations of PRP plus freezing solution with 1:1 proportion (semen to solution). Sperm freezing solution is added slowly by drops to the semen, immersed in Nitrogen vapor and transferred to the liquid Nitrogen.

Real Time PCR studies to measure gene expression

Preparation of primers

1. Add sterile distilled water in the amounts determined by the company to each tube containing primer, and centrifuge. A concentration of 100 pmol is obtained.
2. Store this solution as the main stock at -20°C.
3. Take 10 µL of each primer R, F; mix it with 90 µL of water to obtain a volume of 100 µL. The concentration will be 10 pmol (**Table II**).

Real-time PCR technique

To determine the concentration of genes under study, fluorescent dyes or fluorescent oligonucleotide indicators are used. During PCR reaction, as the concentration of

Figure 4: Stages of preparing PRP.

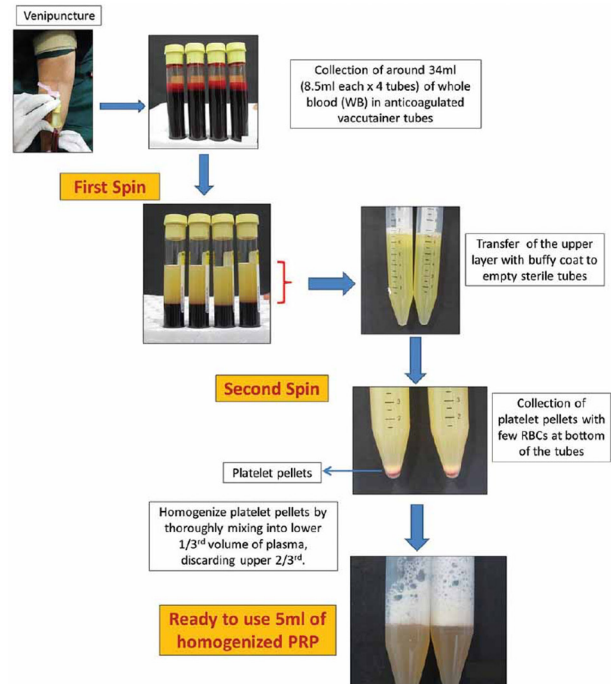

the given genes increases, the amount of fluorescence in solution increases as well. By measuring the fluorescent light intensity at the end of each cycle, a curve is finally obtained. Then the concentration of target genes in the sample under study is measured using standard charts.

Steps of cDNA synthesis: After RNA extraction using HyperScript™ RT premix (with Random hexamer) kit by Gene All Company, cDNA was synthesized. The extracted RNA with appropriate concentration and volume of 20µl of DEPC water is added to 0.2 ml microtube of the intended company (**Table III**).

cDNA synthesis temperature is as follows in **table IV**. After cDNA synthesis, they are stored at -70°C.

Table II: Sequence of primers used.

Accession No.	Product size(bp)	Primer	Gene
NM_001357943.2	92	TGGCTACAGCAACAGGGTG CTCTTGTGCTCTTGTCTGGG	Forward Reverse GAPDH
NM_001291429.2	149	CGGCAACTTCAACTGGGG TCCAGCCCAACAGCCG	Forward Reverse BAX
NM_000657.3	114	GGTGCCGGTTTCAGGTACTCA TTGTGGCCCTTCTTTGAGTTCG	Forward Reverse BCL2
NM_032996.3	120	CAGTCCCAGATTCTCAAGG GATGTTCTTCACTGTGGGGC	Forward Reverse Cas9

Table III: Components of cDNA synthesis.

Amount	Compounds
10µl	HyperScript™ RT premix (with Random hexamer)
1pg - 2µg	Extracted RNA
Final volume should be 20µl	DEPC water

Table IV: Temperature process of cDNA synthesis.

Time	Temperature	Primer
5 min	25	Random hexamer
55 min	55	
5 min	95	

Optimization

To analyze interpretation of the intended gene expression value, an internal control gene or a housekeeping gene is required. Main genes are BCL₂, BAX and CASP₉ and the internal control gene is GAPDH¹¹. For optimization and achieving the best results, all components required for the experiment were tested in different concentrations and different temperatures which finally the most optimal concentration and temperature were selected (Table V to XII).

Note: The optimal temperature and concentration is the one that displays a single pick thawing curve in real time PCR test.

Note: Housekeeping genes are genes that are expressed consistently in all tissues of the body, such as GAPDH.

Table V: Optimal concentration of Real Time PCR reaction for GAPDH.

Concentration	The amount required for total volume of 20 µl	Compounds
—	10 µl	real Q-plus 2x Master mix Green
5µm	0.5 µl	PrimerF
5µm	0.5 µl	PrimerR
—	1 µl	cDNA
—	Up to 20µl volume	ddH2O(DW)

Table VI: Real Time PCR plan for GAPDH.

Cycle	Time	Temperature(°c)	Step
1	10 min	95	Initial Denaturation
40	10 sec	95	Denaturation
	40 sec	60	Annealing
	20 sec	72	Extension
1	10 sec	55-95	Melting Curve

Table VII: Optimal concentration of Real Time PCR reaction material for BCL₂.

Concentration	The amount required for total volume of 20 µl	Compounds
—	10µl	real Q-plus 2x Master mix Green
5µm	0.5 µl	PrimerF
5µm	0.5 µl	PrimerR
—	1 µl	cDNA
—	Up to 20µl volume	ddH2O(DW)

Table VIII: Real Time PCR plan for BCL₂.

Cycle	Time	Temperature(°c)	Step
1	10 min	95	Initial Denaturation
40	10 sec	93	Denaturation
	40 sec	59	Annealing
	25 sec	72	Extension
1	10 sec	55-95	Melting Curve

Table IX: Optimal concentration of Real Time PCR reaction material for BAX.

Concentration	The amount required for total volume of 20 µl	Compounds
—	10µl	real Q-plus 2x Master mix Green
5µm	0.5 µl	PrimerF
5µm	0.5 µl	PrimerR
—	1 µl	cDNA
—	Up to 20µl volume	ddH2O(DW)

Table X: Real Time PCR plan for BAX.

Cycle	Time	Temperature(°c)	Step
1	10min	95	Initial Denaturation
40	10sec	93	Denaturation
	40sec	58	Annealing
	25sec	72	Extension
1	10sec	55-95	Melting Curve

Table XI: Optimal concentration of Real Time PCR reaction material for casp₉.

Concentration	The amount required for total volume of 20 µl	Compounds
—	10µl	real Q-plus 2x Master mix Green
5µm	0.5 µl	PrimerF
5µm	0.5 µl	PrimerR
—	1 µl	cDNA
—	Up to 20µl volume	ddH2O(DW)

Table XII: Real Time PCR plan for casp₉.

Cycle	Time	Temperature(°c)	Step
1	10 min	95	Initial Denaturation
40	10 sec	93	Denaturation
	40 sec	59	Annealing
	25 sec	72	Extension
1	10 sec	55-95	Melting Curve

Calculating gene expression value

After the test, once CTs for the reference gene and the intended gene was obtained, ΔΔCT method was used to calculate the gene expression value.

$$\begin{aligned} \text{Groups } \Delta CT &= CT \text{ Target} - CT \text{ GAPDH} \\ \text{Control } \Delta CT &= CT \text{ Target} - CT \text{ GAPDH} \\ \Delta \Delta CT &= \Delta CT \text{ sample} - \Delta CT \text{ Reference} \end{aligned} \quad \rightarrow \quad 2^{-(\Delta \Delta CT)}$$

Gene duplication curve

Duplication curve graph was drawn for BCL₂, Casp₉, BAX and GAPDH, as the internal control gene, by measuring the Fluorescence intensity changes. In this graph, Y-axes represent intensity of Fluorescence signal and X-axes display the reaction number. In the graph, the area where Fluorescence signal is first detected is called the threshold. In other words, this area indicates the amount of product which is duplicated exponentially in all samples so that the Fluorescence leaves the background and begins to rise above it. The cycle where the curve intersects the threshold line for generated Fluorescence is called CT. The lower this point, the greater the number of the intended gene version.

Melting curve

Due to the non-specificity of the fluorescent dye of SYBR Green and for exclusivity of primers and ensuring the duplication of specific pieces as well making sure that non-specific pieces such as primer dimers are not present in the product, melting curve is drawn. This dye binds all double- stranded DNA. Once bound, fluorescent light is detected by the detector. As the quantity of cDNA copies increases during PCR reaction, fluorescence generation increases as well; and then it is stabilized. These changes

are displayed in the fluorescent curve. At the end of PCR reaction, products are melted by increasing temperature and they become two-stranded as the temperature decreases. Fluorescent changes of the specimen in this stage are displayed in the melting curve and it indicates the specificity or non-specificity of the product.

Examining the gene expression value and results of $\Delta\Delta CT$

$$\text{Fold} = \frac{E^{-\text{Ct}_{\text{Treat}} - \text{CT}_{\text{control}}}_{\text{target}}}{E^{-\text{Ct}_{\text{Treat}} - \text{CT}_{\text{control}}}_{\text{ref.}}} \quad (1)$$

Statistical analysis

For data analysis, SPSS version 16 (SPSS, Chicago, IL, USA) was used. Normal distribution of data was determined by Kolmogorov-Smirnov test. Results were reported as Mean \pm standard deviation. Means of the groups were analyzed using one-way analysis of variance (ANOVA) and Post- hoc Tukey test. Values $p < 0/05$ are considered as significant.

Results

Statistical analysis of data in this study indicates that the data are normally distributed. In addition, the effect of platelet-rich plasma on sperm quality, oxidative stress value, and chromatin health was studied; the level of apoptotic BAX expression, anti-apoptotic BCL2 and CASP9 in sperm cells under freezing were examined using sperm analysis techniques, viability, chromatin emission evaluation and Real time to assess changes in sperm molecular and vital parameters under freezing conditions in the presence of platelet-rich plasma and without its presence. In the first phase, samples were obtained from 30-40-year-old patients who referred to Rooya Fertility Center of Jahad Daneshgahi in Qom. Those who met the requirements joined the study by consent. Participants had abstained from sexual intercourse for 2-3 days and met the criteria to join the study. Then macroscopic and microscopic sperm analysis was performed according to WHO 2010 protocol.

Sperm Parameter Means before the freezing process

Sperm parameters were studied in participants before the freezing process. Mean, standard deviation, minimum and maximum values for each parameter is displayed in **table XIII**.

Table XIII: Sperm parameters before freezing.

Sperm parameters before freezing	Min	Max	Mean \pm SD
Specimen volume (ml)	5/1	5/4	324/0 \pm 2/3
Sperm concentration (106/ml)	25	95	754/29 \pm 6/52
Total motility value (%)	45	60	325/10 \pm 2/51
Progressive movement (%)	35	55	875/7 \pm 7/42
Vitality (%)	45	90	215/20 \pm 7/69
Normal morphology (%)	4	7	315/1 \pm 1/5

Determining optimal concentration of platelet-rich plasma

To determine the optimal concentration of platelet-rich plasma in freezing process, parameters of sperm motility (%), progressive movement (%), concentration (million/milliliter), morphology (%), vitality (%) and coiled-tail (%) were evaluated and the right concentration was selected accordingly.

Examining sperm motility percentage

The results show that the fresh sperm group had the highest motility rate and the frozen and melted sperm with concentration of 0.00% PRP had the lowest motility compared to other groups. ANOVA test showed that the freeze-thawing process causes significant reduction in the percentage of sperm motility (%) in groups ($p < 0.0001$).

Tukey post- hoc test showed that:

- The mean difference between fresh sperm group and other groups is significant.
- The mean difference between 0.00% PRP group and other groups is significant.
- The mean difference between 2.5%PRP group and 25%PRP group is not significant but it is significantly different from other groups.
- The mean difference between 5%PRP group and 10%PRP group is not significant but it is significantly different from other groups.
- The mean difference between 10%PRP group and groups of 5%PRP and 20%PRP is not significant but it is significantly different from other groups.
- The mean difference between 20%PRP group and 10%PRP group is not significant but it is significantly different from other groups.
- The mean difference between 25%PRP group and 2.5%PRP group is not significant but it is significantly different from other groups.

Comparison of the means of sperm motility percentage is displayed in the **figure 5**.

Figure 5: Comparison of the means of sperm motility percentage

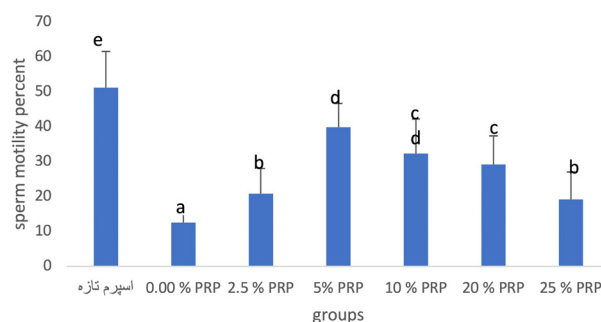

Calculating the percentage of sperm progressive movement

Results of the **figure 6** show that 25% PRP group has the lowest and 25% PRP has the greatest percentage

of sperm progressive movement. One-way analysis of variance (ANOVA) test showed a significant mean difference in sperm progressive movement percentage (%) between the groups ($p < 0.0001$).

Tukey post- hoc test showed that:

- The mean difference between fresh sperm group and other groups is significant.
- The mean difference between 0.00% PRP group and groups of 20%PRP and 25%PRP is not significant but it is significantly different from other groups.
- The mean difference between 2.5%PRP group and groups of 20%PRP and 25%PRP is not significant but it is significantly different from other groups.
- The mean difference between 5%PRP group and 10%PRP group is not significant but it is significantly different from other groups.
- The mean difference between 10%PRP group and groups of 2.5%PRP and 5%PRP is not significant but it is significantly different from other groups.
- The mean difference between 20%PRP group and groups of 0.00%PRP and 25%PRP is not significant but it is significantly different from other groups.
- The mean difference between 25%PRP group and groups of 0.00%PRP and 20%PRP is not significant but it is significantly different from other groups.

Different letters represent a significant difference between groups and similar letters represent that there is no significant difference. Comparison of the means of the percentage of sperm progressive movement is displayed in the **figure 6**.

Figure 6: The mean of sperm progressive movement percentage.

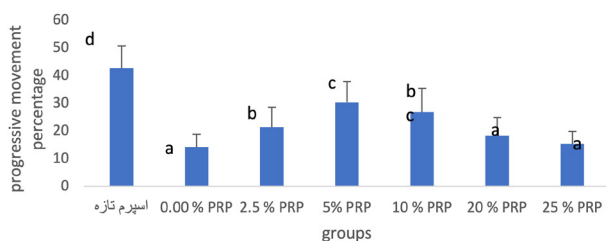

Different letters represent a significant difference between groups and similar letters represent that there is no significant difference ($p < 0.05$).

Assessing the percentage of sperm with coiled-tail

Papanicolaou method was used to assess the percentage of sperm with coiled-tail which is displayed in **figure 7**. The highest percentage of the sperm with coiled-tail is found in 0.00%PRP group and the lowest percentage is found in the fresh sperm group.

One-way analysis of variance (ANOVA) test showed a significant mean difference in the percentage of the

sperm with coiled-tail (%) between the groups ($p < 0.027$).

Tukey post- hoc test showed that:

- The mean difference between fresh sperm group and other groups is significant.
- The mean difference between 0.00%PRP group and groups of 5%PRP and fresh sperm is significant but it is not significantly different from other groups.
- The mean difference between 2.5%PRP group and fresh sperm group is significant but it is not significantly different from other groups.
- The mean difference between 5%PRP group and groups of fresh sperm and 0.00%PRP is significant but it is not significantly different from other groups.
- The mean difference between 10%PRP group and fresh sperm group is significant but it is not significantly different from other groups.
- The mean difference between 20%PRP group and fresh sperm group is significant but it is not significantly different from other groups.
- The mean difference between 25%PRP group and fresh sperm group is significant but it is not significantly different from other groups.

Comparison of the means of the percentage of the sperm with coiled-tail is reported in the **figure 7**.

Figure 7: The mean of the percentage of the sperm with coiled-tail

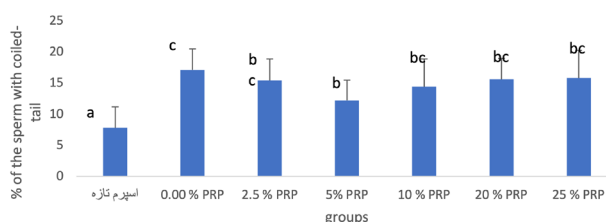

Different letters represent a significant difference between groups and similar letters represent that there is no significant difference ($p < 0.05$).

Figure 7¹: Sperm morphology illustrated in Papanicolaou way before freezing (a), after freeze-thaw (b) and the sperm with coiled-tail due to freezing process (c)

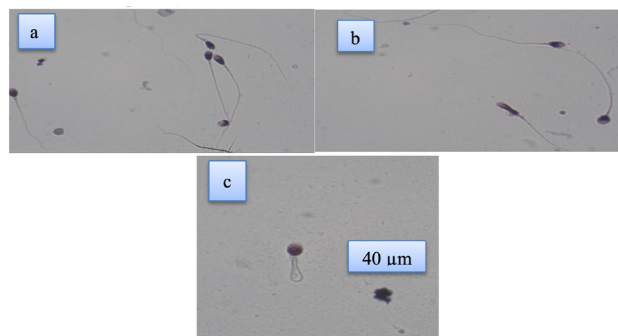

Assessing sperm concentration (million/milliliter)

The lowest sperm concentration is found in 20%PRP group and the highest concentration is found in the fresh sperm group. One-way analysis of variance (ANOVA) test showed a significant mean difference in sperm concentration between the groups ($p= 0.004$).

Tukey post- hoc test showed that:

- The mean difference between fresh sperm group and other groups is significant.
- The mean difference between 0.00%PRP group and groups of 10%PRP, 20%PRP and 25%PRP is not significant but it is significantly different from other groups.
- The mean difference between 2.5%PRP group and 5%PRP group is not significant but it is significantly different from other groups.
- The mean difference between 5%PRP group and 2.5%PRP group is not significant but it is significantly different from other groups.
- The mean difference between 10%PRP group and groups of 0.00%PRP, 20%PRP and 25%PRP is not significant but it is significantly different from other groups.
- The mean difference between 20%PRP group and groups of 0.00%PRP, 10%PRP and 25%PRP is not significant but it is significantly different from other groups.
- The mean difference between 25%PRP group and groups of 0.00%PRP, 10%PRP and 20%PRP is not significant but it is significantly different from other groups.

Figure 8: The mean of sperm concentration in the fresh sperm group and frozen-thawed sperm groups with PRP concentrations.

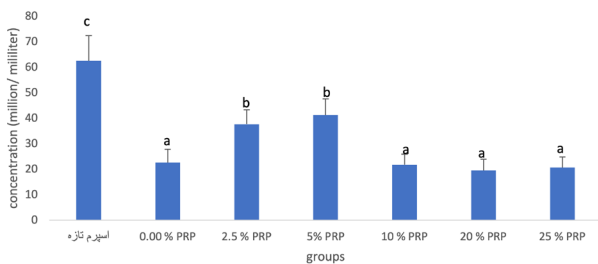

Different letters represent a significant difference between groups and similar letters represent that there is no significant difference ($p<0.05$).

Comparing the effect of different concentrations of platelet-rich plasma on DNA fragmentation in the fresh sperm and the frozen-thawed sperm

Chromatin emission evaluation test was used to assess DNA fragmentation which is indicated in **figure 9**. The lowest rate of DNA fragmentation is found in the fresh sperm group and the greatest amount is found in 0.00%PRP. One-way analysis of variance (ANOVA) test showed a significant mean difference in ROS between the groups ($p= 0.012$).

Tukey post- hoc test showed that:

- The mean difference between fresh sperm group and other groups is significant.
- The mean difference between 0.00%PRP group and other groups is significant.
- The mean difference between 2.5%PRP group and groups of 10%PRP, 20%PRP and 25%PRP is not significant but it is significantly different from other groups.
- The mean difference between 5%PRP group and 10%PRP group is not significant but it is significantly different from other groups.
- The mean difference between 10%PRP group and 5%PRP group is not significant but it is significantly different from other groups.
- The mean difference between 20%PRP group and groups of 2.5%PRP, 10%PRP and 25%PRP is not significant but it is significantly different from other groups.
- The mean difference between 25%PRP group and groups of 2.5%PRP, 10%PRP and 20%PRP is not significant but it is significantly different from other groups.

Figure 9: Comparison of DNA fragmentation percentage.

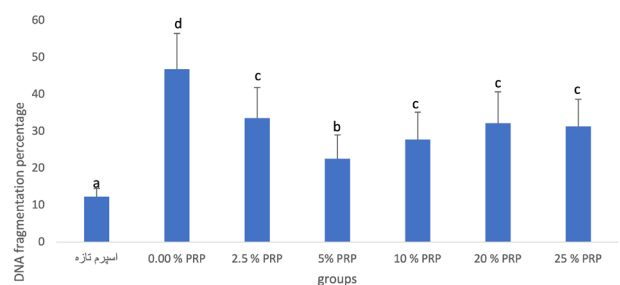

Different letters represent a significant difference between groups and similar letters represent that there is no significant difference ($p<0.05$) (**Figure 10**).

Figure 10: DNA fragmentation by staining Chromatin emission evaluation.

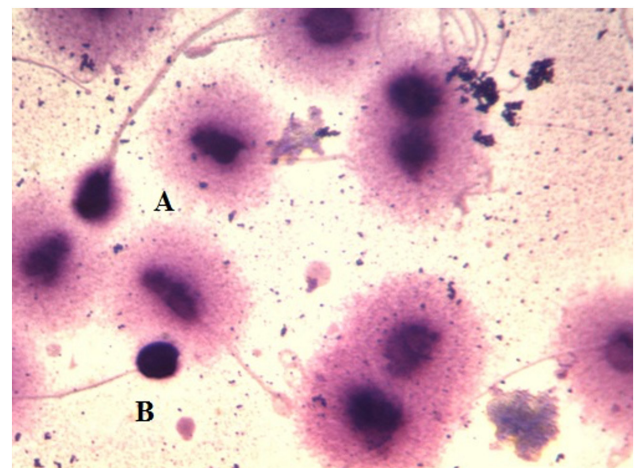

The effect of different concentrations of platelet-rich plasma on expression of CASPASE9 Apoptosis in the frozen-thawed sperm

Expression level of CASPASE9 Apoptosis in samples was calculated using Real Time PCR and the values are reported in the **figure 11**.

- The ratio of expression level of CASPASE9 Apoptosis in the frozen-thawed sperm with 0%PRP to the fresh sperm increased by 9.91 times which was significant ($p < 0.0001$).
- The ratio of expression level of CASPASE9 Apoptosis in the frozen-thawed sperm with 2.5%PRP to the fresh sperm increased by 6.03 times which was significant ($p < 0.0001$).
- The ratio of expression level of CASPASE9 Apoptosis in the frozen-thawed sperm with 5%PRP to the fresh sperm increased by 2.22 times which was significant ($p < 0.039$).
- The ratio of expression level of CASPASE9 Apoptosis in the frozen-thawed sperm with 10%PRP to the fresh sperm increased by 5.52 times which was significant ($p < 0.0001$).
- The ratio of expression level of CASPASE9 Apoptosis in the frozen-thawed sperm with 20%PRP to the fresh sperm increased by 6.55 times which was significant ($p < 0.0001$).
- The ratio of expression level of CASPASE9 Apoptosis in the frozen-thawed sperm with 25%PRP to the fresh sperm increased by 8.38 times which was significant ($p = 0.001$).

References

1. Kumaresan A, Siqueira A, Hossain M, Bergqvist A. Cryopreservation-induced alterations in protein tyrosine phosphorylation of spermatozoa from different portions of the boar ejaculate. *Cryobiology*. 2011; 63(3):137-44
2. Buanayuda G. W, Lunardhi H, Mansur I. G. Effect of In-Vitro Alpha Lipoic Acid Addition on Spermatozoa Motility in Sperm Preparation Process. *Folia Medica Indonesiana*. 2019; 55(4):50-246
3. Andrade-Rocha F. Sperm parameters in men with suspected infertility. Sperm characteristics, strict criteria sperm morphology analysis and hypoosmotic swelling test. *The Journal of reproductive medicine*. 2001; 46(6):577-82
4. Ghandehari Alavijeh R, Shaygannia E., Tavalae M, Nasr-Esfahani M. H. Effect of alpha-lipoic acid antioxidant on sperm parameters and treatment of infertile men. *Medical Science Journal of Islamic Azad University-Tehran Medical Branch*. 2020; 30(1):16-24
5. Gomaa AM, Abd El-Mottaleb NA, Aamer HA. Antioxidant and anti-inflammatory activities of alpha lipoic acid protect against indomethacin-induced gastric ulcer in rats. *Biomedicine & Pharmacotherapy*. 2018; 101:188-94
6. Hezavehei M, Sharafi M, Kouchesfahani HM, Henkel R, Agarwal A, Esmaeili V, Shahverdi A. Sperm cryopreservation: A review on current

Figure 11: Changes of caspase9 expression level.

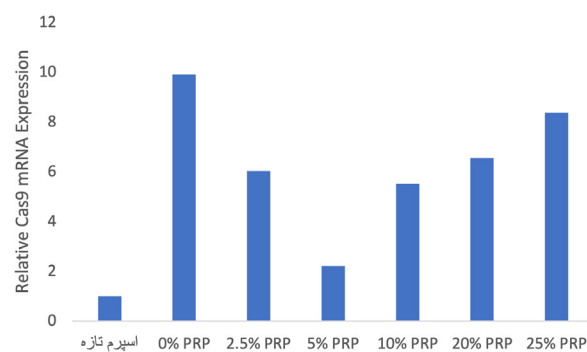

Conclusion

Study results show that concentrations of 5 and 10 %, as the best doses of platelet-rich plasma in the freezing process, significantly protect the parameters of motility, viability and morphology of the sperm; they also cause significant decrease in DNA fragmentation due to freezing ($p < 0.05$). Gene expression results shows that optimal dose of platelet-rich plasma increases the expression level of BAX, BCL₂ and Caspas9 genes ($p < 0.05$) and the ratio of BAX/BCL₂ shows a significant increase as well.

Conflict of interest

Authors do not have any conflict of interest to declare.

molecular cryobiology and advanced approaches. *Reprod Biomed Online*. 2018 Sep;37(3):327-339. doi: 10.1016/j.rbmo.2018.05.012.

7. İnanan BE, Kanyılmaz M. Effect of alpha-lipoic acid on oxidative stress, viability and motility in the common carp (*Cyprinus carpio*) spermatozoa after short-term storage and cryopreservation. *Cryobiology*. 2020 Jun;94:73-79. doi: 10.1016/j.cryobiol.2020.04.006

8. Lestari SW, Lestari SH, Pujianto DA. Sperm quality after swim up and density gradient centrifugation sperm preparation with supplementation of alpha lipoic acid (ALA): A preliminary study. Paper presented at the AIP Conference Proceedings. 2018.

9. Li C, Miao X, Li F, Wang S, Liu Q, Wang Y, Sun J. Oxidative Stress-Related Mechanisms and Antioxidant Therapy in Diabetic Retinopathy. *Oxid Med Cell Longev*. 2017;2017:9702820. doi: 10.1155/2017/9702820.

10. Ren F, Feng T, Dai G, Wang Y, Zhu H, Hu J. Lycopene and alpha-lipoic acid improve semen antioxidant enzymes activity and cashmere goat sperm function after cryopreservation. *Cryobiology*. 2018; 84: 27-32

11. Tavalae M, Torki BB, Azadi L, Nasr E M. Human sperm cryopreservation update in treatment of infertility. 2018;8(4): 332-53

ORIGINAL

Prevalence of adverse drug effects of anti-retroviral drugs on HIV-positive patients receiving anti-retroviral treatment in General Hospital Onitsha, Anambra, Nigeria

Prevalencia de los efectos adversos de los medicamentos antirretrovirales en pacientes seropositivos que reciben tratamiento antirretroviral en el Hospital General de Onitsha, Anambra, Nigeria

**Emmanuella Chidimma Ofoelo¹ , David Chinaechem Innocent¹ ,
Ifeoma Lucy Ofoelo² , Advait Vasavada³ , Stanley Chinedu Eneh⁴**

1. Department of Public Health, Federal University of Technology Owerri, Imo State, Nigeria 2. Anti-Retroviral Unit, General Hospital Onitsha, Anambra State, Nigeria 3. MP Shah Medical College, Jamnagar, India
4. Department of Community Health, Obafemi Awolowo University, Ile-Ife, Osun State, Nigeria

Corresponding author

David Chinaechem Innocent
E-mail: innocentdc1@gmail.com

Received: 8 - XII - 2022

Accepted: 7 - I - 2023

doi: 10.3306/AJHS.2023.38.03.27

Abstract

Background: The wide use and acceptability of antiretroviral treatment has really helped in fighting HIV and keeping infected patients healthy and reducing the risk of further transmission and because of that HIV has become less life threatening. The general objective of this study was to determine the prevalence of adverse drug reactions of antiretroviral drugs on HIV patients receiving care in General Hospital Onitsha.

Methods: A descriptive cross sectional study was adopted to obtain findings on the Prevalence of Adverse Drug Reaction of Antiretroviral Drugs on HIV-positive patient in General Hospital Onitsha. A non-probability convenient sampling technique was used to determine a sample size of 310 respondents for the study and data was collected from all of them with the use of a detailed questionnaire. Data was analyzed using the SPSS version 22 and Microsoft excel. Chi-square was used to test association between variables.

Results: From the analysis, it showed that 65.8% of the respondents are female and adults in the age bracket of 29-48 years. 51.9% were married and majority of the respondents (80%) are of the Igbo origin. Also a good number of them (n=200, 64.5%) are using TDF+3TC+DTG. Only 37.1% of the respondents are found to have had an experience of adverse drug reactions in which skin rash, peripheral neuropathy and gastrointestinal problems are prevalent with percentages of 32.2, 23.5 and 22.6 respectively.

Conclusion: Adverse drug reactions associated with antiretroviral drugs in General Hospital Onitsha was found not to be prevalent and they occur mostly in people who are in the early years of treatment initiation. This study emphasized the need to monitor at risk and vulnerable patients to know when they have developed an event as a result of treatment. It is highly recommended that intensive and close follow-up of patients, especially for those in their early years of treatment initiation for early detection and quick management of adverse drug reaction.

Keywords: Adverse Drug Effects, HIV, Anti-retroviral Drugs, HIV-Positive Patients, Prevalence.

Resumen

Antecedentes. El amplio uso y la aceptación del tratamiento antirretroviral han ayudado realmente a luchar contra el VIH y a mantener sanos a los pacientes infectados y a reducir el riesgo de nuevas transmisiones, por lo que el VIH se ha convertido en una amenaza para la vida. El objetivo general de este estudio fue determinar la prevalencia de las reacciones adversas a los medicamentos antirretrovirales en los pacientes con VIH que reciben atención en el Hospital General de Onitsha.

Métodos. Se adoptó un estudio transversal descriptivo para obtener resultados sobre la Prevalencia de Reacciones Adversas a los Medicamentos Antirretrovirales en pacientes VIH positivos en el Hospital General de Onitsha. Se utilizó una técnica de muestreo conveniente no probabilístico para determinar un tamaño de muestra de 310 encuestados para el estudio y se recogieron datos de todos ellos con el uso de un cuestionario detallado. Los datos se analizaron con el SPSS versión 22 y Microsoft Excel. Se utilizó el chi-cuadrado para probar la asociación entre las variables.

Resultados. Del análisis se desprende que el 65,8% de los encuestados son mujeres y adultos en la franja de edad de 29 a 48 años. El 51,9% estaban casados y la mayoría de los encuestados (80%) son de origen igbo. Además, un buen número de ellos (n=200, 64,5%) utiliza TDF+3TC+DTG. Sólo el 37,1% de los encuestados ha experimentado reacciones adversas al fármaco, en las que prevalecen las erupciones cutáneas, la neuropatía periférica y los problemas gastrointestinales, con porcentajes de 32,2, 23,5 y 22,6 respectivamente.

Conclusión. Se encontró que las reacciones adversas a los medicamentos antirretrovirales en el Hospital General de Onitsha no son prevalentes y ocurren principalmente en las personas que están en los primeros años de la iniciación del tratamiento. Este estudio enfatiza la necesidad de monitorizar a los pacientes de riesgo y vulnerables para saber cuándo han desarrollado un evento como resultado del tratamiento. Se recomienda encarecidamente realizar un seguimiento intensivo y estrecho de los pacientes, especialmente de los que se encuentran en los primeros años de inicio del tratamiento, para la detección precoz y el manejo rápido de las reacciones adversas a los medicamentos.

Palabras clave: Efectos adversos de los medicamentos, VIH, medicamentos antirretrovirales, pacientes seropositivos, prevalencia.

Introduction

Anti-retroviral treatment is the most effective tool in helping fight the Human Immunodeficiency Virus (HIV) by keeping infected patients healthy and reducing the risk of further transmission. As countries implement the 2017 World Health Organization (WHO) treatment guidelines, which require all people living with HIV to be on long-term treatment¹, it is proven that effective treatment results in a decrease in viral load, a boost in the number of CD4 counts, and clinical improvement of the HIV-infected patient². Therefore, ARV drugs have brought highly significant hope to people living with HIV as millions of eligible HIV-infected patients have access to life-prolonging ARV drugs, which has led to a reasonable decrease in HIV-related morbidity and mortality³. As a result, HIV has gone from a life-threatening to a chronic condition as a result of the wide use and accessibility of anti-retroviral treatment (ART) among HIV patients⁴. It is estimated that out of the 35.3 million people living with HIV worldwide, only 10.6 million were receiving ART in 2012, with nearly 6.6 million HIV/AIDS related deaths worldwide having been prevented using ART⁵. According to⁶, the sub-Saharan African region is most affected by HIV; more than 67% of the people were infected with HIV, and 72% of the patients have died since 2008 due to Acquired Immune Deficiency Syndrome (AIDS)⁷. At the same time⁶, reports indicated that approximately 36.7 million people were living with HIV/AIDS, with only 18.2 million receiving anti-retroviral treatment globally.

In 2004, Nigeria received over 400 million dollars in funding to scale up ART –a funding that was partly implemented by Family Health International under the Global HIV/AIDS Initiative Nigeria (GHAIN) project– and this resulted in the influx of ART into the country at an increased level³. The establishment of eligibility is attained using clinical staging and CD4 count (Stage I or II with a CD4 count less than 350 or stage IV irrespective of CD4 counts for adults; CD4 less than 25% for children less than 11 months and CD4 less than 20% for children between the ages of 12-35 months) as a criteria regarding Nigerian national guidelines⁸.

Despite these gains, adverse reactions to these medicines remain a highly significant public health concern, which stands to contradict the effectiveness of anti-retroviral treatment². Adverse drug reactions are a critical component of HIV/AIDS care and treatment as they should be evaluated for the prevalence and pathogenesis of ADRs to inform clinical management⁹. The occurrence of ADRs may negatively affect the quality of life of patients as well as adherence to the treatment, and the spectrum of ADRs is wide and varied, making it difficult to identify the principal cause¹⁰. ADRs are highly significant in the effort to diminish toxicities that are most likely to increase the prevalence of chronic diseases of ageing in the HIV-positive population⁴. A better understanding of the ADRs

of ARV drugs among HIV patients could help specialists to optimize therapy and also improve the care given to HIV-positive patients⁹.

Adverse drug reactions are the most common reason for poor adherence to ART³. Non-adherence to anti-retroviral treatment regimens remains common, leading to considerable deterioration of the disease and enhanced HC expenditure¹¹. Noncompliance is also thought to increase viral load, drug resistance, and treatment failure¹². Chronic use of ARV drugs, multiple pills taken at once, exclusion from society and being lonely due to stigma and discrimination, and treatment failure are the major problems associated with highly active anti-retroviral treatment¹³. Adverse drug reactions (ADRs) are regarded as the most prevailing cause of mortality among people living with HIV/AIDS as they are significantly involved in treatment interruptions, regimen changes, treatment failure, and non-adherence among patients on ART¹³. ADRs are brought about by many factors, including stock-out of drugs, poor health service quality, and treatment interruptions, which limit the treatment options, increase the cost of treatment programs, and might increase resistant viruses to the point of being transmissible if left untreated¹⁴. ADRs are not exactly life-threatening but can impact negatively on the quality of life as it impairs the patients' willingness to adhere to their regimen and influences the decisions made about health care¹⁵.

The stock out of drugs interrupts the treatment and may contribute to ARV drug resistance. That could urge regimen change to deter ARV drug resistance. The longer a patient is on ART, the less likely they will experience ADRs, possibly as a result of stability in the ARV regimen, coming after many changes and eventually settling on an acceptable regimen¹⁶. Previous research has shown that patients over the age of 38 years have a significantly higher recurrence of ADRs than those under the age of 30 years^{17,3}. Also, gender differentials were also found with females having higher risks of adverse drug effects than males, as females experienced higher abnormal fat distribution and peripheral neuropathy that occurred at a significantly younger age compared to males¹⁶. In a multisite trial in Africa, it was found that tenofovir therapy was associated with a 1.3% rate of significant nephrotoxicity, which was comparable to other regimens, thereby showing no significant toxicity difference between tenofovir and other regimens³. This raises a sentinel sign that perhaps drug response to TDF in this setting is not in conformity with the results from other studies where the drug profile of TDF has been superior over AZT and d4T.

The problematic occurrence of widespread underreporting of ADRs and the importance of addressing shortcomings effectively in pharmacovigilance activities in the public healthcare setting need to be appropriately addressed¹⁸. Furthermore, knowledge regarding antiretroviral (ARV) toxicity in developing countries is limited. These toxicities

can result in unknown long-term effects and compromise patient confidence and adherence¹⁹. Poor adherence, particularly at levels lower than 95%, has a negative impact on HIV outcome²⁰. Over the years, some adverse drug reactions have been observed in every course of anti-retroviral therapy⁷. The occurrence of adverse drug reactions negatively affects the quality of life of patients as well as adherence to the treatment, and the spectrum of adverse events is wide and varied, thereby making it difficult to identify the principal cause sometimes¹⁰. Different types of anti-retroviral adverse drug reactions occur commonly among patients. Because the ADRs vary in their severity, a common cause of ADR is therefore poor adherence. Also, monitoring safety and toxicity related to ART remains a challenge facing the public health sector. Spontaneous reporting of ADRs is a very inefficient system for detecting drug-related conditions, leading to an underestimation of the burden due to adverse drug reactions. Structured surveillance tracks HIV positive patients who are on ART to assess drug-related morbidity and mortality over time. The objective of this study was to determine the prevalence of adverse drug effects of anti-retroviral drugs on HIV-positive patients who are receiving anti-retroviral treatment in General Hospital Onitsha.

Methods

Design

A descriptive cross-sectional design was adopted in the study on the prevalence of adverse drug effects of anti-retroviral drugs on HIV-positive patients who are receiving anti-retroviral treatment in General Hospital Onitsha.

Study Setting

This study was carried out at General Hospital Onitsha, Onitsha South Local Government Area, Anambra State. General Hospital Onitsha is a government-owned tertiary healthcare facility located in the cosmopolitan city of Onitsha in the southeastern zone of Nigeria. It has several departments, just like every other government hospital. Services at the ART unit are provided by a group of competent health and non-health professionals. The unit provides comprehensive HIV-related services such as voluntary counselling and testing (VCT), provider-initiated testing and counselling (PITC), PMTCT, pediatric HIV care, and treatment and support for PLWHAs.

Inclusion Criteria

The study recruited HIV-positive patients less than 18 years who were receiving anti-retroviral treatment in General Hospital Onitsha, at least for a minimum of 6 months.

Exclusion Criteria

The study excluded HIV-positive patients receiving treatment in General Hospital Onitsha who refused to give in their consent for the study. The study also excluded

HIV-positive patients who are absent at the time of study, those who are below the age of 18, and those who picked up ARVs only once at the pharmacy.

Sampling

The researcher made use of only three hundred and ten HIV-infected patients receiving anti-retroviral care in General Hospital Onitsha. The respondents will be interviewed in order to gather information for the progress of the study.

Sample Size determination

The sample size was determined using the Yamene formula (1967) for sample size determination.

$$n = \frac{N}{1 + Ne^2}$$

Where;

n is the desired sample size

N is the population size (953)

e is margin of error (0.05)

$$n = \frac{953}{1 + 953(0.05)^2}$$

$$n = \frac{953}{1 + 953 * 0.0025}$$

Therefore,

$$n = 281.74$$

Furthermore, to account for Non Response Rate, the sample size was increased by 10% = 0.10 = 281.74 x 0.10 = 28.1

$$n = 281.7 + 28.17 = 309.9$$

Approximately = 310

Sampling Techniques

A non-probability-based convenience sampling technique was employed for the study on the prevalence of adverse drug effects of anti-retroviral drugs on HIV-1 and HIV-2 patients who are receiving anti-retroviral treatment in General Hospital Onitsha.

Data Collection

A self-administered structured questionnaire was used for the study on the prevalence of adverse drug effects of anti-retroviral drugs on HIV-positive patients who are receiving anti-retroviral treatment in General Hospital Onitsha. Data was obtained using a self-administered, semi-structured questionnaire. This was done with the aid of two (2) field assistants who work in the ART department unit of the hospital to aid the researcher in the data collection process. Both the researcher and the research assistants were involved in retrieving the administered questionnaire for data analysis.

Validity and Reliability of the Research Instrument

The questionnaire as the instrument of data collection was developed by the researcher and submitted to the project supervisor for face validity and proper scrutiny as well as two other lecturers in order to ensure that the questionnaire meets the objectives of study before the distribution of questionnaires for reliability testing.

The reliability of the data instrument was determined using the test retest method. The researcher gave copies of the questionnaire to some respondents outside the area of study by the researcher, thereby pre-testing the questionnaire twice before administering it to the respondents. This area shares similar characteristics with General Hospital Onitsha, which was used for this study. On reliability correlation testing using SPSS, the Cronbach alpha value of 0.76 was obtained. The closeness of this value to 1 indicates that the instrument of data collection is very reliable.

Method of Data Analysis

The data that was gathered from the questionnaire was analyzed using the statistical package for social sciences (SPSS) version 22 and Microsoft Excel. Descriptive statistics, which were expressed in frequency tables and percentages, were used to describe the characteristics in the study of the subjects. Inferential statistics were used with a confidence interval of 95% and a P-value of 0.05 for interpreting significance and correlation.

Ethics

A letter of introduction was obtained from the ethics committee, department of public health, Federal University

of Technology Owerri (FUTO). The letter was handed over to the Head of Department, Anti-retroviral Therapy (ART) unit, General Hospital Onitsha, in order to get his consent before carrying out the research in the unit. The purpose of the research was explained to each respondent and verbally informed consent was obtained from them before inclusion in the study. Also, the anonymity of the respondents was assured and ensured. The confidentiality of the information they gave had to be maintained.

Results

A total of 310 respondents were included in the final analysis. 310 questionnaires were carefully distributed and collected by the researcher for the study. The questionnaires were filled properly and cross-checked for accuracy. The flow diagram below (**Figure 1**) summarizes the distribution of patients according to their antiretroviral treatment regimen. This study final analysis includes only HIV-positive patients above the age of 18 who are receiving antiretroviral treatment in General Hospital Onitsha.

The flow diagram (**Figure 1**) summarizes the distribution of respondents according to their antiretroviral treatment regimen. As shown in the figure above, 66.5% (n=206) of the total population use combination of two nucleoside reverse transcriptase inhibitors (NRTI) and an integrase inhibitor (I); 29.6% (n=92) use combination of two NRTI and a non-nucleoside reverse transcriptase inhibitor (NNRTI); and the remaining 3.9% (n=12) use the combination of two NRTI and a protease inhibitor (PI).

Figure 1: Flow diagram of patients and ART regimen received at treatment initiation.

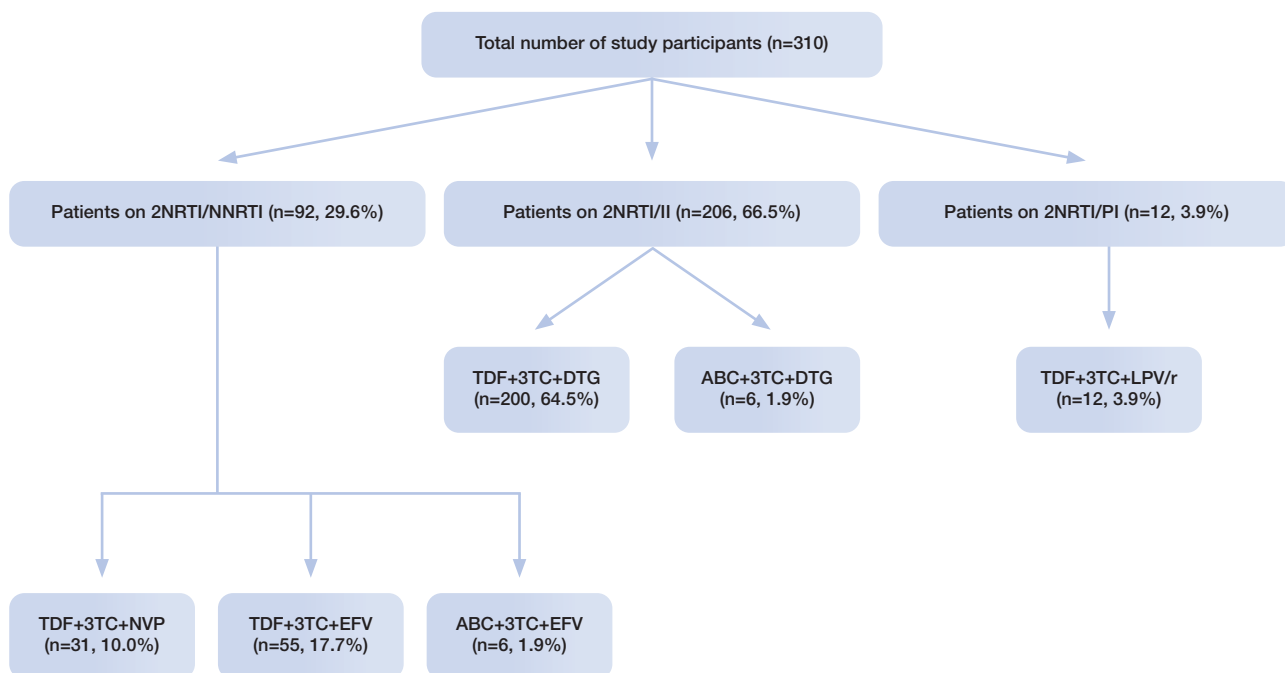

Table I: Socio-demographic Characteristics of Study Participants. (N=310).

Variables	Subgroup	Frequency (N=310)	Percentage (100%)
Age	18-28	59	19.0
	29-38	71	22.9
	39-48	115	37.1
	49-58	35	11.3
	58 and above	30	9.7
Gender	Male	106	34.2
	Female	204	65.8
Marital status	Single	66	21.3
	Married	161	51.9
	Divorced/Separated	31	10.0
	Widowed	52	16.8
Ethnicity	Igbo	248	80
	Hausa	37	11.9
	Yoruba	17	5.5
	Others	8	2.6
	Educational level	Primary	44
Secondary		75	24.2
Tertiary		104	33.5
Uneducated		87	28.1
Occupation	Trader	137	44.2
	Farmer	95	30.6
	Civil servant	33	10.6
	Student	21	6.8
	Others	7	2.3
	Unemployed	17	5.5

Source: Field data, 2021.

Table I above shows that a good number of the study participants were females (n=204, 65.8%) and adults in the age bracket of 39-48 years. Many of the participants (n=104, 33.5%) have attained tertiary education, 87(28.1%) are uneducated, 75(24.2%) are recorded to have achieved only secondary education and 44(14.2%) attained only primary education. Regarding marital status, married people are highest accounting for 51.9% of the total population, seconded by the singles (n=66, 21.3%), then the widowed (n=52, 16.8%) and the divorced/separated (n=31, 10%). Considering ethnicity, Igbos are leading amounting to 80% of the population, followed by the Hausas (11.9%), then the Yorubas (5.5%) and then few people from other tribes(2.6%). It is also shown in the table above that most of the study participants are traders with a percentage of 44.2, seconded by farmers with a percentage of 30.6, then comes civil servants, students, people of other occupations not mentioned and unemployed people with a percentage of 10.6, 6.8, 2.3, and 5.5 respectively.

Figure 2: A bar chart representing the age distribution of respondents.

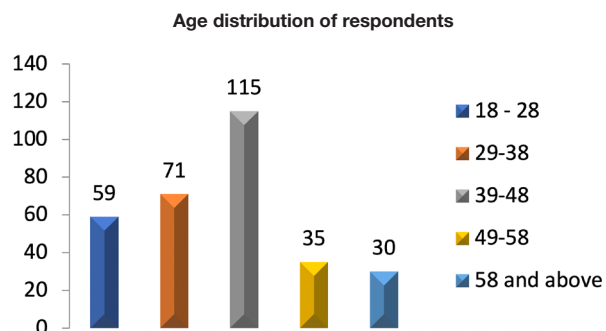

Figure 2 shows a diagrammatic representation of the age distribution of the respondents plotted against the frequency of respondents found to be within these age groups. As shown in the diagram, the leading age group is those within the ages of 39-48 years (n=115), while the least one is found to be those who are 58 years and above (n=30).

Table II: Ascertain Type, Frequency and Dosage of ARV in Use.

Characteristics	Sub-group	Frequency (n=310)	Percent (100%)
How long the patient has been on treatment	6 months-2 years	139	44.8
	2-6 years	57	18.4
	7-10 years	98	31.6
	Above 10 years	16	5.2
The ARV combination in use	2NRTI/II	206	66.5
	2NRTI/NNRTI	92	29.6
	2NRTI/PI	12	3.9
The exact drug combination in use	TDF+3TC+DTG	200	64.5
	TDF+3TC+EFV	55	17.7
	TDF+3TC+LPV/r	12	3.9
	ABC+3TC+EFV	6	1.9
	TDF+3TC+NVP	31	10.0
	ABC+3TC+DTG	6	1.9
Prescribed dosage of the drug	1 tab/daily	288	92.9
	2 tabs/daily	22	7.1
Adherence to everyday use of drug	Yes	199	64.2
	No	35	11.3
	Sometimes	76	24.5
Adherence of everyday use of drug with respect to time and dosage	Yes	178	57.4
	No	46	14.8
	Sometimes	86	27.7

Source: Field data, 2021.

Table II indicates that 139(44.8%) to have been on treatment for the first 2 years, 57 are reported to fall within those receiving treatment for the past 2-6 years, 98 have been on treatment for about 7-10 years and the rest (n=16,5.2%) have been on treatment for over 10 years. It also shows that all that study participants make use of ARV drugs of which the common ones are TDF+3TC+DTG (66.5%), TDF+3TC+EFV (17.7%) and TDF+3TC+NVP (10.0%) while the least common ones are TDF+3TC+LPV/r (3.9%) and ABC+3TC+EFV and ABC+3TC+DTG with percentages of 1.9% each. Almost all the respondents (92.9%) report their prescription to be 1tab/day and the rest (7.1%) take theirs twice daily. 64.2% of the study participants adhere to everyday use of drug, 11.3% do not adhere while 24.5% adhere sometimes. 57.4% of the total population adhere to everyday use with respect to time and dosage, 14.8% do not and the remaining 27.7% sometimes adhere to everyday use of drugs with respect to time and dosage.

Figure 3 is a pie chart representing the how long respondents have been on treatment, hence the time treatment initiation. From the chart, it is seen that 44.8% of the total population are within the first three years of treatment, 18.4% reported to have been on treatment for about 3-6 years, 31.6% have been on treatment for about 7-10 years, and the remaining 5.2% have been on antiretroviral treatment for more than 10 years.

Figure 3: A pie chart representing how long a patient has been on treatment.

Distribution of how long respondents have been on ART

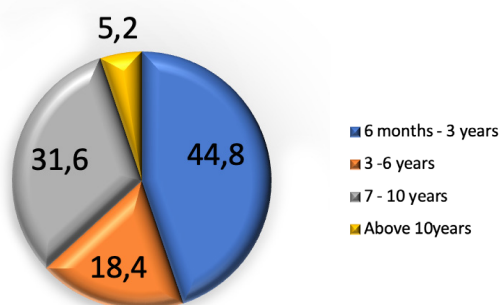

Table III: Ascertaining the incidence of ADRs resulting from ARV drugs.

Variables	Sub-groups	Frequency	Percent
Ever experienced any ADR	Yes	115	37.1
	No	195	62.9
What type of ADR experienced	Neuropathy	27	23.5
	Skin rash/itching	37	32.2
	Insomnia	10	8.7
	Dizziness	15	13.0
	Gastro-intestinal	26	22.6
Presence of severe condition as a result of ADR	Yes	26	22.6
	No	89	77.4

Source: Field data, 2021.

Table III shows that only 37.1% (n=115) adverse drug reaction of antiretroviral drugs of which 22.6% experience severe conditions as a result and 77.4% never had such experience. The adverse events experienced by the respondents include skin rash/itching, neuropathy, insomnia, dizziness and gastro-intestinal symptoms with percentages of 32.2, 23.5, 22.6, 13.0 and 8.7 respectively.

Figure 4: A bar chart showing percentage distribution of ADR types.

Percentage Distribution of ADR Types

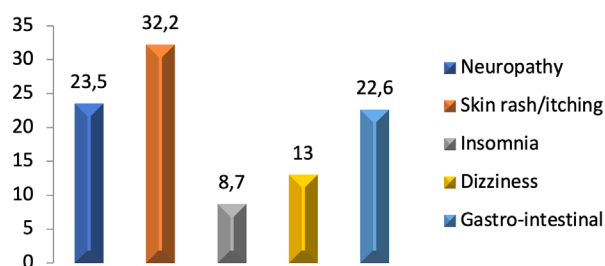

Table IV: Determining rate of occurrence and result on switching.

Variables	Sub-groups	Frequency	Percent
Rate of occurrence	Weekly	0	0
	Monthly	21	18.3
	Yearly	40	34.8
	Rarely	54	46.9
Ever had a change in regimen	Yes	73	63.5
	No	42	36.5
Result of ADRs after drug switching	Disappeared	29	39.7
	Reduced/contained	44	60.3

Source: Field data, 2021.

Table IV shows that of 115 patients that experience adverse events, 21(18.3%) have them occur every month, 40(34.8%) experience it yearly and 54(46.9%) rarely have the experience. 63.5% of those that experience adverse events have had a change in regimen, of which 39.7% had the adverse events disappear after switching and 60.3% had their adverse events reduced or contained.

Figure 4 is another bar chart representing the percentage distribution of the types of adverse drug reactions (ADRs) experienced by the respondents. As shown above, the

Table V: Association of participants' demographic factors and adherence to prescribed dosage and frequency of drug use.

Variables	Sub-group	Patients with ADR	Patients without ADR	Chi-square test value	Df	P value	Decision
Age	18 - 28	3	36	80.393	4	.0001	Sig
	29 - 38	20	51				
	39 - 48	48	67				
	49 - 58	14	21				
	59 and above	30	0				
Gender	Male	55	51	15.100	1	.0001	Sig
	Female	60	144				
Educational Level	Primary	24	20	19.517	3	.0001	Sig
	Secondary	20	55				
	Tertiary	28	76				
	Uneducated	43	44				
Marital Status	Single	28	38	1.788	3	.618	Not Sig.
	Married	58	103				
	Divorced	9	22				
	Windowed	20	32				
How long patient has been on treatment	6 mths - 3 yrs	75	64	51.972	3	.0001	Sig
	3 - 6 years	27	30				
	7 - 10 years	12	86				
	Above 10 yrs	1	15				
Adherence to with respect to dosage and time	Yes	36	142	51.305	2	.0001	Sig
	No	29	17				
	Sometimes	50	36				

Source: Field data, 2021.

most prevalent ADRs are skin rash, neuropathy and nausea/vomiting with percentages of 32.2, 23.5 and 22.6 respectively. The least occurring ones are dizziness and insomnia with percentages of 13.0 and 8.7 respectively.

Test of Hypothesis

Table V shows that age, gender, educational level, the time of treatment initiation and the patients' adherence to everyday use of drugs with respect to prescribed dosage and time all appear to have a correlation with the patients' experience of adverse effect with p value of 0.0001 each. Marital status is not significant in determining the experience of adverse drug reaction of antiretroviral drugs.

Discussion

From the analysis, it is revealed that the majority of the respondents (80%) of the study are of Igbo origin. This is because the study was conducted in the Southern part of Nigeria as the hospital is located in Onitsha, Anambra State. Considering the socio-demographic characteristics of the respondents, with regards to gender and age, a good number of respondents (65.8%) are females, and most respondents are within the age range of 29-48 years old. This is in accordance with the findings of²¹, that the majority of these patients are females and young adults in the age bracket of 25-45 years old. This gender difference, though not statistically significant, is found in much other related research carried out in African countries. It is also consistent with other studies conducted in Nigeria that show a feminization of the HIV epidemic^{22,23,21}. Findings from the study show that 44.8% of the respondents are within their first three years of treatment, 18.4% reported to have been on treatment for about 3-6 years, 31.6% have been on treatment for about 7-10 years, and the remaining 5.2% have been on antiretroviral treatment for more than 10 years. A good percentage of the respondents (66.5%) use a combination of two nucleoside reverse transcriptase inhibitors (NRTI) and an integrase inhibitor (II). Following suit is the group using the 2NRTI/NNRTI combination. People who make use of the ABC+3TC+EFV and ABC+3TC+DTG are 6 and 6, respectively, which is a minority representative of the study participants. This is because the patients who use these drugs are ones with special cases, for instance, patients with kidney and liver diseases and children (which we didn't use for this study).

Almost all the respondents (n = 200, 64.5%) make use of TDF + 3TC + DTG. This is because it is the first line regimen and it is suitable for virtually every adult, including pregnant and lactating mothers, and also for adolescents. Meanwhile, TDF + 3TC + LPV is taken by a small number of people (n = 12, 3.9%) because it is a second-line regimen.

Considering the frequency and dosage, it is denoted here that the majority of the study participants (n=199, 64.2%) adhere to everyday use of their drugs, of which 89.4% adhere to everyday use of the drugs with respect to the time and required dosage. 11% of the study participants do not adhere at all, and 24.5% do not adhere all the time as their answers to questions are sometimes. This argues the study conducted by²⁴ that says this presents less than optimal adherence among HIV-positive patients. Almost all respondents (n=288, 92.9%) are taking one tablet per day, while the remainder (n=22, 7.1%) are taking two tablets per day because they are on second-line therapy TDF + 3TC+LPV and abacavir-based regimens. From the findings, 115 participants out of the 310 used for the study were reported to have experienced or be experiencing adverse drug reactions as a result of the use of ARV drugs²³. This represents 37.1 % of the total population and is in accordance with²³. Of the people that have experienced ADRs, 26(22.6%) have experienced a chronic condition as a result of the ADRs, while 89 (77.6%) haven't had such experience. The prevalent ADRs are skin rash/itching, neuropathy and gastro-intestinal symptoms (which include vomiting, nausea, abdominal pain and diarrhea) with percentages of 32.2%, 23.5% and 22.6%, respectively, which is the same as reported by other Nigerian studies^{3,22,21}. In comparison to²³, the study found a lower incidence of antiretroviral drug adverse drug reactions. Adverse events are reported to be most prevalent among people who are in the early years of treatment initiation, and this supports the study³ that found ADRs are more likely to occur within the first 6 months of treatment. The study shows that the 54 respondents(46.9%) out of 115 that were reported to have had an experience of ADR rarely have the occurrence, 40(34.8%) experience it yearly and 21(18.3%) experience it monthly. Also, 63.5% of those reported to be with ADR have had a change in regimen, of which 39.7% (n=29) reported that the ADR had disappeared and 60.3% (n=44) reported ADRs to be reduced or contained. This is because most respondents are still adjusting to the treatment while few are allergic to a combination of the regimen.

Conclusion

Adverse drug reactions to antiretroviral treatment were common in this study and were reported to occur mostly within the early years of treatment initiation. The most prevalent ADRs were skin rash/itching (n=37, 32.2%), neuropathy (n=27, 23.5%) and gastro-intestinal symptoms (n=26, 22.6%). Other rarely occurring but serious cases of ADR include insomnia (n=10, 8.7%) and dizziness (n=15, 13%), which were also observed. Adverse Drug Reactions are significantly predicted by the time of therapy initiation as people within the early years of initiation were reported to experience ADRs more than others, with a percentage of 65.2%. This study

emphasizes the need to monitor at-risk and vulnerable or low-immune patients to know when they have developed an event as a result of treatment.

Recommendations

As a result of this study, an intensive and close follow-up of patients, especially in the early years of treatment initiation, is highly recommended for early detection of ADR and quick management. These ADRs should be properly documented in order to provide accurate data for further studies or research. Patients who are not able to respond effectively to first-line therapies should be identified and placed on effective second-line therapies. Valuable information on patients' responsiveness to treatment should be made available to physicians in-charge and concerned NGOs like USAID when there is a need to modify HAART regimens. Further study using larger and more complete data is also recommended.

Limitations of the Study

With regards to the study, there is a tendency that non-clinical ADRs were overlooked. There is a possibility of under-reporting of ADRs by patients and caregivers. The researcher was not able to relate the factors that caused the ADRs, which would have played an important role in the interpretation of the result.

Ethics Approval and consent to Participate

Not Applicable.

Consent to Publish

Not applicable.

Availability of Data and Materials

The Data set from the study are available to the corresponding author upon request.

Competing Interests

Authors have declared that they have no competing interests.

Funding

No funds were received for this study.

Acknowledgements

Not Applicable.

Questionnaire on adverse drug effects of anti-retroviral drugs on HIV-positive patients who are receiving anti-retroviral treatment in General Hospital Onitsha, Anambra

SECTION A

This section covers for the Demographic Data

1. Gender

Male Female

2. Educational qualifications

Primary
Secondary
Tertiary
No formal education

3. How old are you?

18-2829-3839-4849-5859 and above

4. What ethnic group do you belong to?

Igbo Hausa Yoruba Others

5. What is your occupation

Trader Farmer Civil servant Student
Others

6. Marital status

Single Married Divorced Widowed

SECTION B

This section is to ascertain frequency of use and dosage of ARV drugs

7. How long have you been on antiretroviral therapy?

- 6 months-2 years
2-6 years
7-10 years
Above 10 years

8. Which of the ARV drug combination are you on?

- 2NRTI/NNTRI 2NRTI/ PI 2NRTI/II

9. What is the specific regimen in use?

- TDF+3TC+DTG
TDF+3TC+EFV
TDF+3TC+LPV/r
ABC+3TC+EFV
TDF+3TC+NVP
ABC+3TC+DTG

10. What is the prescribe dosage of the drug

- 1tab/day 2tabs/day

11. Do you adhere to everyday use of drugs

- Yes No Sometimes

12. Do you adhere to drugs use with respect to prescribed time and dosage

- Yes No Sometimes

SECTION C

To ascertain the adverse drug reaction experienced

13. Have you ever noticed any change in your body since the use of the drug

- Yes No

14. If yes, what kind of changes

- Neuropathy
Skin rash/itching
Insomnia
Dizziness
Gastrointestinal issues
If others, Indicate

15. Do you have any chronic condition as a result of the dug intake

- Yes No

SECTION D

To determine the rate of ADRs

16. How often do you notice these change

- Weekly Monthly Yearly Rarely

17. Have you ever had any change in regimen

- Yes No

18. What is the result of ADRs after switching

- Disappeared Contained /Reduced

Thanks for your maximum co-operation, your confidentiality is guaranteed

APPENDIX 3

Research workplan

S/N	ACTIVITY	TIME FRAME	PERSONNEL RESPONSIBLE
1	Development and submission of research proposal	8 weeks	Researcher
2	Project proposal	1 day	Researcher
3	Recruitment and training of research assistants	1 week	Researcher
4	Pre-testing of instrument of data collection (questionnaire)	1 week	Researcher
5	Analysis of pre-tested questionnaire	5 days	Researcher
6	Modification of data collection tool	2 days	Researcher
7	Data collection	4 weeks	Researcher and research assistants
8	Analysis of data and report conclusion	6 weeks	Researcher
Total time spent for the study		21 weeks and 1 day	

References

- World Health Organization. HIV Drug Resistance surveillance guideline-2015 Update. www.who.int
- WHO. Assuring safety of preventive chemotherapy interventions for neglected tropical diseases. practical advice for national program managers on the prevention, detection and management of serious adverse effects 2010. Available at: http://whqlibdoc.who.int/publications/2011/9789241502191_eng.pdf
- Eluwa GI, Badru T, Akpoigbe KJ. Adverse drug reactions to antiretroviral therapy (ARVs): incidence, type and risk factors in Nigeria. *BMC Clinical Pharmacology* 2012; 12:7. doi:10.1186/1472-6904-12-7
- Hawkins T. Understanding and managing the adverse effects of antiretroviral therapy. *Antiretroviral Resource* 2010. 85: 201-9.
- Joint United Nations Program on HIV/AIDS. Global report: UNAIDS reports on the global AIDS Epidemic 2013. Geneva: Switzerland
- UNAIDS. Global report: UNAIDS report on the global AIDS epidemic *UNAIDS Geneva; 2010*.
- Tatiparthi R, Mamo Y. Prevalence of ADRs and associated factors of antiretroviral treatment on HIV positive adults at Jush. *Indian Journal of Pharmacological Practice* 2014;7(4):8-15
- Federal Ministry of Health, Nigeria. National guidelines for HIV/AIDS treatment and care in adolescents and adults 2010.
- Takaki I, Quirelli L, Cuman R. Adverse drug reaction in HIV infected people treated with HAART in Maringa, Southern Brazil. *Tropical Journal of Pharmaceutical Research* 2017; 16(4):939-45. <http://www.tjpr.org>
- Lartey M, Asante-Quashie A, Essex A, Kenu E, Gang V, Neequaye A. Adverse drug reaction to anti-retroviral therapy during the early ART period at Tertiary Hospital in Ghana. *Pan African Medicine Journal* 2014; 18:25. Doi:10.11604/pamj.2014.18.25.3886
- Gelaw Y, Adugna B, Tsegave A, Melaku T, Kefale B. Coping strategies for Adverse Effects of Antiretroviral Therapy among Adult HIV patients attending University of Gondar Hospital, Gondar, Northwest Ethiopia: a cross-sectional study. *AIDS Research and Treatment* 2018;18(7):91-8
- Rajesh R, Vidyasagar S, Nandakumar K. Highly active anti-retroviral therapy induced adverse drug reactions in Indian human immunodeficiency virus positive patients. *Pharmacy Practice* 2011;9(1):48-55.
- Parchure R, Kulkarni V, Darak T. Growth pattern of HIV infected Indian children in response to ART: a clinic based cohort study. *Indian Journal of pediatricians* 2015; 82(6):519-24
- WHO. Using early warning indicators to prevent HIV Drug resistance 2010. www.who.int
- Ermias A, Gurmesa G, Mesfin M, Mengistu A. Adverse drug reaction monitoring in Ethiopia: Analysis of case reports, 2002-2007. *Ethiopian Journal of Health Development* 2011;25(2):168-73
- Dube M, Summers R, Tint K-S, Mayayise G. A pharmacovigilance study of adults on highly active anti-retroviral therapy, South Africa: 2007-2011. *Pan African Medical Journal* 2012;11:39.
- Srikanth A, Babu S, Yadav H, Jain SK. Incidence of Adverse Drug Reactions in human immunodeficiency virus positive patients using high active anti-retroviral therapy. *Journal of advanced pharmacological technology resource* 2012; 3:62-67.
- Ruud KW, Srinivas SC, Toverud EL. Addressing gaps in pharmacovigilance practices in the antiretroviral therapy program in the Eastern Cape Province, South Africa. *Res Social Adm Pharm.* 2010 Dec;6(4):345-53. doi: 10.1016/j.sapharm.2009.11.006.
- Kyeyune R, Saathoff E, Ezeamama AE, Löscher T, Fawzi W, Guwatudde D. Prevalence and correlates of cytopenias in HIV-infected adults initiating highly active antiretroviral therapy in Uganda. *BMC Infect Diseases* 2014; 10;14:496. doi: 10.1186/1471-2334-14-496.
- Sweileh WM. Global research output on HIV/AIDS-related medication adherence from 1980 to 2017. *BMC Health Serv Res.* 2018 Oct 10;18(1):765. doi: 10.1186/s12913-018-3568-x.
- Abah IO. Adverse Drug Reaction to Antiretroviral Drugs: Effect on Virologic failure in a Nigerian Cohort of HIV-infected Adults on First Line Antiretroviral Therapy. *Journal of International Association of Providers of AIDS care* 2017; 2325957414589192.
- Agu KA, Oparah AC. Adverse Drug Reactions to Antiretroviral Therapy: Results on spontaneous reporting system in Nigeria. *Perspectives in Clinical Research* 2014;4(2): 117-24
- Masenyetse L, Manda S, Mwambi H. An assessment of adverse drug reactions among HIV positive patients receiving antiretroviral treatment in South Africa. *AIDS research therapy* 2015; 12(6):1-8
- Ndashimye E, Arts EJ. The urgent need for more potent antiretroviral therapy in low-income countries to achieve UNAIDS 90-90-90 and complete eradication of AIDS by 2030. *Infect Dis Poverty.* 2019 Aug 2;8(1):63. doi: 10.1186/s40249-019-0573-1.

Características clínicas en pacientes adultos hospitalizados por COVID-19 en un hospital de la región de Ñuble, Chile: Estudio transversal descriptivo

Clinical characteristics in adult patients hospitalized for COVID-19 in a hospital in the Ñuble region, Chile: descriptive cross-sectional study

Addí Rhode Navarro-Cruz¹ , José M. Chavez-Montecinos² ,
Javier Herrera-Fuentealba³ , Ashuin Kammar García⁴ , Gladys Quezada-Figueroa⁵ ,
Obdulia Vera-López¹ , Martín Lazcano-Hernández¹ , Orietta Segura-Badilla⁵ 

1. Departamento de Bioquímica-Alimentos, Facultad de Ciencias Químicas, BUAP, México.

2. Hospital Clínico Herminda Martín, Chillán Chile. 3. Departamento de salud Municipal, El Carmen, Chile.

4. Dirección de Investigación, Instituto Nacional de Geriátria, México City, México.

5. Facultad de Ciencias de la Salud y los Alimentos, Departamento de Nutrición y Salud Pública, Universidad del Bío-Bío, Chile.

Corresponding author

Orietta Segura Badilla
E-mail: osegura@ubiobio.cl

Received: 12 - XII - 2022

Accepted: 8 - I - 2023

doi: 10.3306/AJHS.2023.38.03.37

Resumen

Fundamentos: La pandemia por COVID-19 ha dejado repercusiones humanas y económicas sin precedentes, siendo un importante problema de Salud Pública con importantes tasas de contagio y hospitalización, por lo que se hace necesario no dejar de investigar todo lo que pudiera brindar luz para un mejor manejo en situaciones venideras.

Métodos: El presente estudio se enfocó a investigar las características sociodemográficas y clínicas en pacientes adultos hospitalizados por COVID-19 en el Hospital Clínico Herminda Martín de Chillán, durante el periodo marzo a junio 2020. Se trata de un estudio descriptivo de corte transversal en el que la muestra correspondió a 126 pacientes adultos hospitalizados por COVID-19.

Resultados: La edad media fue 56,2 años, el 60,3% eran hombres, la media de hospitalización fue de 9 días, la indicación médica y el fallecimiento fueron los principales motivos de egreso. Los pacientes críticos tenían una media de edad de 55,9 años, el 68,9% eran hombres, las principales enfermedades fueron la hipertensión arterial, diabetes mellitus y obesidad, la disnea, tos y fiebre fueron los signos y síntomas más comunes, la media de hospitalización fue de 16 días, la indicación médica y fallecimiento fueron los principales motivos de egreso y la ferritina. PCR y VHS alta fueron los hallazgos de laboratorio más importantes.

Conclusión: Se concluye que al aumentar el número de alteraciones de laboratorio al ingreso se incrementa el riesgo de ingreso a UCI y por tanto de mortalidad.

Palabras clave: COVID-19; tipo de hospitalización; paciente crítico.

Abstract

Background: The COVID-19 pandemic has left unprecedented human and economic repercussions, being an important Public Health problem with significant rates of contagion and hospitalization, so it is necessary not to stop investigating everything that could shed light for better management in future situations.

Methods: The present study focused on investigating the sociodemographic and clinical characteristics in adult patients hospitalized for COVID-19 at the Hospital Clínico Herminda Martín de Chillán, during the period March to June 2020. The sample corresponded to 126 adult patients hospitalized for COVID-19 in a descriptive cross-sectional study.

Results: The mean age was 56.2 years, 60.3% were men, the mean hospital stay was 9 days, and medical indication and death were the main reasons for discharge. The critical patients had a mean age of 55.9 years, 68.9% were men, the main diseases were arterial hypertension, diabetes mellitus and obesity, dyspnea, cough and fever were the most common signs and symptoms, the mean hospitalization was After 16 days, and medical indication and death were the main reasons for discharge and high ferritin. CRP and HSV were the most important laboratory findings.

Conclusion: It is concluded that increasing the number of laboratory abnormalities on admission increases the risk of ICU admission and therefore mortality.

Key words: COVID-19; type of hospitalization; critical patient.

Introducción

En diciembre de 2019 surgió la aparición de un nuevo coronavirus emergente, el que se reconoció por primera vez en diciembre de 2019, tras aislarlo y confirmarlo mediante lavado bronco alveolar, PCR y cultivo en pacientes hospitalizados por neumonía grave en Wuhan, China¹.

Este nuevo coronavirus fue nombrado oficialmente por la Organización Mundial de la Salud (OMS) como SARS-CoV-2 y COVID-19 a la enfermedad producida². Desde sus inicios la enfermedad provocada por este coronavirus se transformó en un importante problema de salud pública a nivel nacional e internacional, alcanzando importantes tasas de contagio a nivel global.

En Chile, el primer caso confirmado de SARS-CoV-2 se reportó el 3 de marzo de 2020, en la Ciudad de Talca, Región del Maule³, y para finales del primer trimestre de 2021, se habían confirmado un total de 1.151.717 casos a nivel nacional, reportándose un total de 83.117 ingresos hospitalarios⁴, y aunque en el año 2022 ya se puede hablar de que la mayoría de las personas que padecen COVID-19 sufren síntomas de intensidad leve a moderada y se recuperan sin necesidad de manejo especial, algunas personas continúan desarrollando casos graves que requieren atención médica y manejo clínico y hospitalario especiales.

En cuanto a las características de los pacientes hospitalizados por COVID-19, se ha reportado a nivel internacional una mayor prevalencia en hombres y edades promedios que varían desde los 39-59 años⁵⁻⁸. Por otra parte, los signos y síntomas clínicos más comunes han sido fiebre, tos, fatiga, disnea y mialgias^{9,10}. Respecto a las enfermedades subyacentes, la hipertensión, obesidad, diabetes mellitus han sido las más prevalentes⁵⁻⁸. En lo que respecta a los exámenes de laboratorio, se ha destacado la linfocitopenia, aumento de la proteína C reactiva, lactato de deshidrogenasa aumentada y leucocitopenia como los principales exámenes alterados⁸. Por todo esto, el objetivo de este trabajo fue determinar las características sociodemográficas y clínicas según tipo de hospitalización en los pacientes adultos hospitalizados por COVID-19 en el Hospital Clínico Herminda Martín de Chillán, durante el periodo marzo a junio 2020.

Material y métodos

Estudio de carácter descriptivo y corte transversal. La población estuvo conformada por 150 pacientes de 18 años y más hospitalizados por COVID-19 en todas las unidades de hospitalización del Hospital Clínico Herminda Martín de Chillán (HCHM), desde el 1 de marzo al 30 de junio de 2020. Fueron excluidos

aquellos pacientes hospitalizados con resultado de RT-PCR negativo o indeterminado, pacientes diagnosticados por COVID-19 durante el transcurso de una hospitalización por otra causa o mediante cualquier prueba distinta a RT-PCR y pacientes de los cuales no se pudo acceder a ficha clínica, totalizando una muestra de 126 pacientes hospitalizados.

Las variables de estudio fueron clasificadas en sociodemográficas (edad y sexo) y clínicas (unidad de hospitalización, tipo de hospitalización, enfermedades subyacentes, estadía hospitalaria, motivo de egreso, síntomas clínicos, signos clínicos y exámenes de laboratorio). La información inicial se obtuvo a través de una base de datos de pacientes de 18 años y más diagnosticados e ingresados por COVID-19. Se dispuso además de acceso a la ficha clínica de cada paciente, configurada en formato papel, de la cual se corroboraron y obtuvieron los datos sociodemográficos y clínicos. Para la obtención de los resultados de exámenes, se contó con acceso a la base de datos de exámenes de laboratorio de cada uno de los pacientes incluidos en el estudio.

La recolección de los datos comenzó posterior a la autorización del estudio por parte del Comité Ético Científico (CEC) del HCHM, con la solicitud y obtención del listado de pacientes hospitalizados. Estos fueron clasificados según el tipo de hospitalización de acuerdo con los criterios de presentación clínica definidos por el HCHM¹¹. De esta forma, los pacientes hospitalizados en sala básica fueron clasificados como no críticos y los pacientes hospitalizados en la Unidad de Paciente Crítico Adulto (UCI-UTI) fueron clasificados como críticos. La información recogida fue registrada en una ficha de datos elaborada por los investigadores, en la cual cada paciente recibió un código encriptado.

Aspectos éticos

Este estudio fue aprobado por el Comité Ético Científico (CEC) del Hospital Clínico Herminda Martín. Respecto al uso del consentimiento informado (CI), se solicitó al CEC la eximición expresa de este, posterior al análisis de los potenciales riesgos que significaba para los investigadores y los pacientes.

Análisis estadístico

Los datos cuantitativos son presentados como mediana y rango intercuartílico (Q1-Q3), mientras que los datos cualitativos se presentan como frecuencias y porcentajes. Los supuestos de normalidad se verificaron por medio de la asimetría y curtosis. Las comparaciones cuantitativas se realizaron por medio del análisis U de Mann-Whitney, mientras que las comparaciones cualitativas se realizaron por medio de la prueba de Chi cuadrada, Chi cuadrada de tendencia o la prueba exacta de Fisher, la elección de la prueba dependió del número de categorías a comparar y la frecuencia en cada casilla.

Se realizaron diversos modelos multivariados de regresión logística para determinar el efecto del número de síntomas, comorbilidades y alteraciones de laboratorio en el requerimiento de cuidados críticos y mortalidad. Cada modelo multivariable fue ajustado por sexo y edad, las variables se incluyeron en cada modelo multivariado por medio del método Enter. Los datos de cada modelo se resumieron como Odds Ratio (OR) y su respectivo intervalo de confianza al 95% (IC95%), así como el coeficiente B y su error estándar para la mejor interpretación de los resultados. Se consideró como significancia estadística bilateral $p < 0.05$, todos los análisis estadísticos se realizaron en el paquete estadístico SPSS en su versión 21.

Resultados

El estudio fue realizado con una muestra de 126 pacientes hospitalizados. En cuanto a las características generales, se destaca una media de 56,2 años ($DE \pm 17,5$), siendo el grupo de 55 años y más el de mayor prevalencia con un 54,7%. Respecto al sexo, el 60,3% eran hombres. En relación a las características clínicas, el 59,5% fue ingresado en el CR (Centro de Responsabilidad) Medicina Interna y el 35,7% en el CR Paciente Crítico Adulto. De este modo, 45 pacientes se clasificaron como críticos y 81 como no

Tabla I: Distribución de los pacientes del estudio según características generales (n=126).

Características generales		
Edad, media en años, DE	56.2	± 17.5
Edad, mediana en años, IQR	56	43-68.5
Edad en rangos	n	%
18-24	4	3.2
25-34	10	7.9
35-44	21	16.7
45-54	22	17.5
55-64	32	25.4
65 o más	37	29.3
Sexo	n	%
Hombre	76	60.3
Mujer	50	39.7
Unidad de hospitalización	n	%
CR Medicina Interna	75	59.5
CR Paciente crítico adulto	45	35.7
CR Cirugía indiferenciada	5	4.0
Unidad de emergencia.	1	0.8
Tipo de hospitalización	n	%
Crítico	45	35.7
No crítico	81	64.3
Estadía hospitalaria, media días, DE	9	9.3
Enfermedades subyacentes	n	%
Ninguna	31	24.6
1	45	35.7
>1	50	39.7
Motivo de egreso	n	%
Indicación médica	106	84.1
Fallecimiento	14	11.1
Traslado	5	4.0
Necesidad de cama	1	0.8

críticos. En cuanto a la estadía hospitalaria, la media de hospitalización fue de 9 días ($DE \pm 9,3$). Finalmente, la tasa de fallecimientos fue de 11,1% (**Tabla I**).

Con relación a la distribución de los pacientes según tipo de hospitalización y síntomas y signos clínicos, el 64,29% de los pacientes fueron críticos y el 35,71% fueron pacientes no críticos. Los síntomas clínicos más frecuentes fueron la disnea y la mialgia tanto en pacientes críticos como en los no críticos, mientras que los signos clínicos más frecuentes fueron la tos y la fiebre en ambos tipos de pacientes (**Tabla II**).

También se muestra la distribución de los pacientes según la presencia de enfermedades subyacentes, las de mayor prevalencia fueron la hipertensión arterial con un 47,6%, diabetes mellitus con un 31,7% y obesidad con un 17,4%. En lo que se refiere al tipo de hospitalización, el 55,5% y 43,2% de los pacientes críticos y no críticos eran hipertensos, el 42,2% y 26% tenían diabetes mellitus y el 22,2% y 14,8% presentaban obesidad (**Tabla III**).

Tabla II: Distribución de los pacientes del estudio según tipo de hospitalización y síntomas clínicos (n=126).

Síntomas y signos clínicos	Tipo de hospitalización		Total
	Crítico (n= 45)	No crítico (n= 81)	
Síntomas clínicos			
Disnea	40 (88.8%)	64 (79.6%)	104 (82.5%)
Mialgias	15 (33.3%)	29 (35.8%)	44 (35%)
Cefalea	13 (28.8%)	16 (19.7%)	29 (23%)
Odinofagia	4 (8.8%)	13 (16%)	17 (13.4)
Dolor torácico	1 (2.2%)	4 (4.9%)	5 (4%)
Anosmia	3 (6.6%)	2 (2.4%)	5 (4%)
Nauseas	3 (6.6%)	2 (2.4%)	5 (4%)
Signos clínicos			
Tos	28 (62.2%)	51 (63%)	79 (62.6%)
Fiebre	25 (55.5%)	38 (47%)	63 (50%)
Diarrea	6 (13.3%)	4 (4.9%)	10 (7.9%)
Vómitos	2 (4.4%)	5 (6.2%)	7 (5.5%)

Tabla III: Distribución de los pacientes en estudio según tipo de hospitalización y enfermedades subyacentes (n=126)

Enfermedades subyacentes	Tipo de hospitalización		Total
	Crítico (n= 45)	No crítico (n= 81)	
Hipertensión arterial	25 (55.5%)	35 (43.2%)	60 (47.6%)
Diabetes Mellitus	19 (42.2%)	21 (26%)	40 (31.7%)
Obesidad	10 (22.2%)	12 (14.8%)	22 (17.4%)
ERC	5 (11.1%)	6 (7.4%)	11 (8.7%)
Dislipemia	4 (8.8%)	3 (3.7%)	7 (5.5%)
Asma	1 (2.2%)	5 (6.2%)	6 (4.7%)
EPOC	-	6 (7.4%)	6 (4.7%)
Hipotiroidismo	3 (6.6%)	1 (1.2%)	4 (3.2%)
Insuficiencia respiratoria	3 (6.6%)	1 (1.2%)	4 (3.2%)
Artrosis	1 (2.2%)	3 (3.7%)	4 (3.2%)
Fibrilación auricular	1 (2.2%)	3 (3.7%)	4 (3.2%)
Fibrosis pulmonar	-	4 (4.9%)	4 (3.2%)
Demencia	-	3 (3.7%)	3 (2.4%)
Insuficiencia cardíaca	1 (2.2%)	2 (2.5%)	3 (2.4%)
VIH	-	1 (1.2%)	1 (0.8%)
Epilepsia	-	1 (1.2%)	1 (0.8%)
Enfermedad autoinmune	2 (2.2%)	1 (1.2%)	3 (2.4%)
Cáncer	1 (2.2%)	2 (2.5%)	3 (2.4%)

Con relación a la estadía hospitalaria según tipo de hospitalización, se observó una media de 15 días (IQR 3-11,5) en pacientes críticos y de solo 6 días (IQR 3-11,7) en pacientes no críticos. Respecto al motivo de egreso, el 84,4% de los pacientes críticos egresaron por indicación médica y el 8,9% por fallecimiento. En cuanto a los pacientes no críticos, el 84% egresó por indicación médica y el 12,3% por defunción (Tabla IV).

En cuanto al resultado de los exámenes de laboratorio, del total de pacientes el 97,9% de los pacientes presentó ferritina aumentada, 91% proteína C reactiva (PCR) alta, 89,4% velocidad de eritro sedimentación globular (VHS) aumentada y 77% un dímero-D alto; por otra parte, en cuanto a los pacientes críticos, el 100% obtuvo un resultado elevado para ferritina, 97,7% presentó una PCR alta, el 95,8% VHS incrementada y 85% dímero-D alto. En relación a los pacientes no críticos, el 96,2% de los pacientes críticos analizados para ferritina obtuvieron un resultado elevado, el 87,6% presentó una PCR alta, el 84,8% una VHS incrementada y el 72,4% un dímero-d alto (Tabla V).

Tabla IV: Distribución de los pacientes en estudio según tipo de hospitalización, estadía hospitalaria y motivo de alta (n=126). Estadía hospitalaria y motivo de egreso.

	Tipo de hospitalización		Total
	Crítico (n= 45)	No crítico (n= 81)	
Estadía, días, media (DE)	15 (±9.4)	6 (±9.3)	9 (±9.3)
Motivo de egreso			
Indicación medica	38 (84.4%)	68 (84%)	106 (84.1%)
Fallecimiento	4 (8.9%)	10 (12.3%)	10 (11.1%)
Traslado	3 (6.6%)	2 (2.4%)	5 (4.0%)
Necesidad de cama	-	1 (1.2%)	1 (0.8%)

Tabla V: Distribución de los pacientes en estudio según tipo de hospitalización y exámenes de laboratorio (n=126)

Exámenes de coagulación	Tipo de hospitalización		Total
	Crítico (n= 45)	No crítico (n= 81)	
Dímero-D (0.0-500 ng/mL)	(40/45)	(69/81)	109
Normal	6 (15%)	19 (27.5%)	25 (23%)
Aumentado	34 (85%)	50 (72.4%)	84 (77%)
VHS (0.0-22 mm/hr)	(24/45)	(33/81)	57
Normal	1 (4.2%)	5 (15.2%)	6 (10.5%)
Aumentado	23 (95.8%)	28 (84.8%)	51 (89.4%)
Linfocitos (25-40 %)	(11/45)	(24/81)	35
Normal	4 (36.4%)	10 (41.6%)	14 (40%)
Disminuido	7 (63.6%)	13 (54.2%)	20 (57.1%)
Aumentado	0 (0%)	1 (4.2%)	1 (2.9%)
A. aminotransferasa (5.0-34.0 U/L)	(37/45)	(46/81)	83
Normal	11 (29%)	19 (41.3%)	30 (35.7%)
Aumentado	27 (71%)	27 (58.7%)	54 (64.2%)
Ferritina (16-243 ng/mL)	(22/45)	(26/45)	48
Normal	0 (0%)	1 (3.8%)	1 (2.1%)
Aumentado	22 (100%)	25 (96.2%)	47 (97.9%)
Proteína C reactiva (0.8-8.2 mg/dL)	(45/45)	(81/81)	126
Normal	1 (2.3%)	10 (12.4%)	11 (8.7%)
Aumentada	44 (97.7%)	71 (87.6%)	115 (91%)
L. Deshidrogenasa (140-271 (U/L)	(40/45)	(55/81)	95
Normal	7 (17.5)	23 (41.8%)	30 (31.6%)
Disminuido	0 (0%)	3 (5.4%)	3 (3.2%)
Aumentado	33 (82.5%)	29 (52.7%)	62 (65.2%)

Discusión

El estudio incluyó un total de 126 pacientes hospitalizados, de los cuales el 60.3% eran hombres, similar a lo reportado en un estudio hecho en España¹⁰ y en la Clínica Indisa de Santiago, Chile¹². La menor hospitalización en mujeres podría ser explicada debido a que son menos susceptibles a las infecciones virales, generan niveles de carga viral más bajos y menos inflamación que en el hombre (13). Respecto a los resultados en relación con la edad, se destaca una media de 56,2 años (DE ±17,5), muy similar a lo encontrado en Europa o en Estados Unidos^{14,15}.

En cuanto al tipo de hospitalización, 45 pacientes fueron clasificados como no críticos y 81 pacientes como críticos, similar a lo reportado por el estudio realizado en la Clínica Indisa de Santiago, Chile¹². Respecto a la estadía hospitalaria, esta alcanzó una media 9 días de hospitalización, resultado equivalente a lo notificado por una investigación realizada en Brasil¹⁶ y similar a lo obtenido en un estudio realizado en la Clínica Alemana de Santiago, Chile¹⁷. En cuanto al motivo de egreso, las principales causas fueron el alta por indicación médica y el fallecimiento, resultados similares a lo reportado por un estudio realizado en Dinamarca¹⁸.

En relación con los resultados de acuerdo al tipo de hospitalización y el sexo, el 68,9% de los pacientes críticos eran hombres y el 55,4% de los pacientes no críticos también lo eran. Esto es similar a lo informado por el estudio realizado en la Clínica Alemana de Santiago¹⁷. Este predominio masculino se provocaría por una diferencia hormonal en los procesos inflamatorios, mayor tendencia a estilos de vida no saludables y una mayor expresión de la ACE2¹⁹. Respecto a la edad, se observa una similitud en la media de edad en ambos tipos de pacientes, resultados que no coinciden con lo obtenido en dos estudios realizados en China, en los cuales el grupo categorizado como grave y crítico alcanzó edades considerablemente más altas^{6,20}. La edad avanzada favorece la progresión desfavorable, dada la mayor presencia de enfermedades, una defensa inmunitaria más débil y mayores niveles de citoquinas pro inflamatorias¹⁹.

En cuanto a los resultados según la presencia de enfermedades subyacentes, la hipertensión arterial, diabetes mellitus y obesidad fueron las más prevalentes, siendo igual a lo descrito en el informe del Departamento de Epidemiología de Chile³ y en dos investigaciones realizadas en España y EEUU^{21,22}. Respecto al tipo de hospitalización, existe un aumento de la prevalencia conforme incrementa la gravedad de los pacientes, similar a lo obtenido en un estudio hecho en EEUU y Suiza^{23,24}. Tanto la hipertensión arterial como la diabetes mellitus implicarían un aumento en la expresión de ACE2 en los tejidos, activación de células

endoteliales e inflamación crónica, lo que agravaría la respuesta inflamatoria²⁵. Además, la obesidad provocaría niveles más altos de IL-6 y un mayor riesgo de trombosis, contribuyendo a un mayor riesgo de COVID-19 grave²⁶.

Respecto a los signos y síntomas clínicos, la disnea, tos y fiebre fueron los más comunes, independiente del tipo de hospitalización, coincidiendo con el informe del Departamento de Epidemiología de Chile³ y un estudio llevado a cabo en España²⁷. Sin embargo, la prevalencia tanto de disnea y fiebre incrementó en directa relación a la gravedad del paciente, similar a lo evidenciado en un estudio hecho en China²⁸. En cuanto a la presencia de tos, fue inferior en los pacientes críticos, siendo contrario a lo evidenciado en un estudio realizado en Etiopía, en el cual existió un incremento de la presencia de tos, conforme se complicó la condición del paciente²⁹.

En relación a la estadía hospitalaria según el tipo de hospitalización, se aprecia una mayor estadía en pacientes críticos, similar a lo evidenciado en un estudio llevado a cabo en Bulgaria³⁰. Respecto al motivo de egreso, no se observaron diferencias en el alta por indicación médica, sin embargo, los pacientes no críticos presentaron una mayor prevalencia de fallecimiento, no concordando con lo obtenido en un estudio realizado en los Países Bajos, en el cual los pacientes graves presentaban una mayor prevalencia de muerte³¹.

En relación a los resultados según los exámenes de laboratorio, los pacientes presentaron principalmente una ferritina aumentada, proteína C reactiva (PCR) alta, velocidad de eritrosedimentación globular (VHS) aumentada y dímero-D elevado, observando un incremento de estos parámetros en pacientes críticos versus pacientes no críticos, resultados comparables con estudios realizados en China, Egipto y Pakistán³²⁻³⁶.

De manera similar a otros datos existentes, nuestros hallazgos fortalecen la correlación entre niveles elevados por ejemplo de dímero-D, proteína C reactiva, LDH y ferritina al ingreso y pronóstico desfavorable

en COVID-19³⁷, y al evaluar el riesgo de ingreso a UCI y mortalidad a partir del número de síntomas, comorbilidades o alteraciones de laboratorio al ingreso (**Tabla VI**), se puede observar que conforme se aumentan el número de alteraciones de laboratorio al ingreso se incrementa el riesgo de ingreso a UCI y de mortalidad. Aproximadamente 0,29 y 0,34 unidades de riesgo por cada alteración de laboratorio al ingreso.

Conclusión

En este estudio las principales comorbilidades de los pacientes críticos de covid-19 fueron la hipertensión arterial, diabetes mellitus y obesidad, estos pacientes presentaron también una estadía más alta que los pacientes no críticos, y sus síntomas y signos clínicos más comunes fueron disnea, tos y fiebre, con ferritina aumentada, PCR alta, velocidad de eritrosedimentación globular VHS aumentada y dímero-D elevado. Se concluye que al aumentar el número de alteraciones de laboratorio al ingreso se incrementa el riesgo de ingreso a UCI y por tanto de mortalidad.

Limitaciones del estudio

La dificultad y espera excesiva en el acceso a ficha clínica de los pacientes, por diversos motivos, debiendo excluir pacientes del estudio por no contar con acceso a ello. La escasa prolijidad y antecedentes recabados respecto a la salud nutricional de los pacientes hospitalizados, donde no se consideró el cálculo del Índice de Masa Corporal (IMC) u otro indicador para clasificar nutricionalmente a los pacientes y al analizar los resultados de laboratorio, tan solo dos exámenes fueron analizados en el total de pacientes analizados, no permitiendo obtener un perfil común de laboratorio para todos los sujetos del estudio.

Conflicto de intereses

Los autores declaran no tener conflicto de intereses respecto a la presente investigación.

Financiamiento

Ninguno.

Tabla VI: Riesgo de ingreso a UCI y mortalidad a partir del número de síntomas, comorbilidades o alteraciones de laboratorio al ingreso.

Modelo para ingreso a UCI	Modelos Univariados				Modelos Multivariados			
	Coefficiente B	EE	OR (IC95%)	Valor de p	Coefficiente B	EE	OR (IC95%)	Valor de p
Número de síntomas	0.15	0.13	1.16 (0.90-1.49)	0.3	0.16	0.14	1.17 (0.89-1.53)	0.2
Número de comorbilidades	0.18	0.14	1.20 (0.91-1.58)	0.2	0.29	0.16	1.33 (0.96-1.83)	0.08
Numero de alteraciones de laboratorio	0.29	0.09	1.33 (1.09-1.61)	0.003	0.29	0.10	1.34 (1.09-1.63)	0.005
Modelo para mortalidad	Coefficiente B	EE	OR (IC95%)	Valor de p	Coefficiente B	EE	OR (IC95%)	Valor de p
Número de síntomas	-0.42	0.21	0.66 (0.43-1.01)	0.05	-0.19	0.23	0.82 (0.52-1.29)	0.4
Número de comorbilidades	0.51	0.20	1.66 (1.12-2.49)	0.01	0.19	0.24	1.22 (0.76-1.95)	0.4
Número de alteraciones de laboratorio	0.34	0.14	1.41 (1.07-1.85)	0.02	0.39	0.16	1.47 (1.08-2.02)	0.02

EE: Error Estándar, IC95%: Intervalo de confianza al 95%.
Modelo multivariado ajustado por edad y sexo.

Citas bibliográficas

- Zhu N, Zhang D, Wang W, Li X, Yang B, Song J, et al. A novel Coronavirus from patients with pneumonia in China, 2019. *N Engl J Med* [Internet]. 2020;382(8):727-33. Disponible en: <http://dx.doi.org/10.1056/nejmoa2001017>
- Naming the coronavirus disease (COVID-19) and the virus that causes it [Internet]. *Who.int*. [citado el 26 de octubre de 2022]. Disponible en: [https://www.who.int/emergencies/diseases/novel-coronavirus-2019/technical-guidance/naming-the-coronavirus-disease-\(covid-2019\)-and-the-virus-that-causes-it](https://www.who.int/emergencies/diseases/novel-coronavirus-2019/technical-guidance/naming-the-coronavirus-disease-(covid-2019)-and-the-virus-that-causes-it)
- Colegiomedico.cl. [Citado el 26 de octubre de 2022]. Disponible en: http://www.colegiomedico.cl/wpcontent/uploads/2020/02/Informe_1_COVID_19_Chile.pdf
- Minsal.cl. [Citado el 26 de octubre de 2022]. Disponible en: <https://www.minsal.cl/wp-content/uploads/2021/03/Informe-Epidemiolo%CC%81gico-107.pdf>
- Wang X, Liu W, Zhao J, Lu Y, Wang X, Yu C, et al. Clinical characteristics of 80 hospitalized frontline medical workers infected with COVID-19 in Wuhan, China. *J Hosp Infect* [Internet]. 2020;105(3):399-403. Disponible en: <http://dx.doi.org/10.1016/j.jhin.2020.04.019>
- Zheng Y, Xu H, Yang M, Zeng Y, Chen H, Liu R, et al. Epidemiological characteristics and clinical features of 32 critical and 67 noncritical cases of COVID-19 in Chengdu. *J Clin Virol* [Internet]. 2020;127(104366):104366. Disponible en: <http://dx.doi.org/10.1016/j.jcv.2020.104366>
- Chen N, Zhou M, Dong X, Qu J, Gong F, Han Y, et al. Epidemiological and clinical characteristics of 99 cases of 2019 novel coronavirus pneumonia in Wuhan, China: a descriptive study. *Lancet* [Internet]. 2020;395(10223):507-13. Disponible en: [http://dx.doi.org/10.1016/S0140-6736\(20\)30211-7](http://dx.doi.org/10.1016/S0140-6736(20)30211-7)
- Li L-Q, Huang T, Wang Y-Q, Wang Z-P, Liang Y, Huang T-B, et al. COVID-19 patients' clinical characteristics, discharge rate, and fatality rate of meta-analysis. *J Med Virol* [Internet]. 2020;92(6):577-83. Disponible en: <http://dx.doi.org/10.1002/jmv.25757>
- Wang X, Fang J, Zhu Y, Chen L, Ding F, Zhou R, et al. Clinical characteristics of non-critically ill patients with novel coronavirus infection (COVID-19) in a Fangcang Hospital. *Clin Microbiol Infect* [Internet]. 2020;26(8):1063-8. Disponible en: <http://dx.doi.org/10.1016/j.cmi.2020.03.032>
- Zhong Z, Li H, Zhu J, Ji P, Li B, Pang J, et al. Clinical characteristics of 2,459 severe or critically ill COVID-19 patients: A meta-analysis: A meta-analysis. *Medicine (Baltimore)* [Internet]. 2021;100(5):e23781. Disponible en: <http://dx.doi.org/10.1097/MD.00000000000023781>
- Fariña C, Esveile C, Calabrano L, Narváez P. Resumen de manejo inicial y en sala de pacientes adultos sospechosos o confirmados COVID-19 del Hospital Clínico Herminda Martín. Chile; 2020.
- Conti P, Younes A. Coronavirus COV-19/SARS-CoV-2 affects women less than men: clinical response to viral infection. *J Biol Regul Homeost Agents* [Internet]. 2020;34(2):339-43. Disponible en: <http://dx.doi.org/10.23812/Editorial-Conti-3>
- Araujo M, Ossandón P, Abarca AM, Menjiba AM, Muñoz AM. Prognosis of patients with COVID-19 admitted to a tertiary center in Chile: A cohort study. *Medwave* [Internet]. 2020;20(10):e8066. Disponible en: <http://dx.doi.org/10.5867/medwave.2020.10.8066>
- Borobia AM, Carcas AJ, Amalich F, Álvarez-Sala R, Monserrat-Villatoro J, Quintana M, et al. A cohort of patients with COVID-19 in a major teaching hospital in Europe. *J Clin Med* [Internet]. 2020;9(6):1733. Disponible en: <http://dx.doi.org/10.3390/jcm9061733>
- Yoshida Y, Gillet SA, Brown MI, Zu Y, Wilson SM, Ahmed SJ, et al. Clinical characteristics and outcomes in women and men hospitalized for coronavirus disease 2019 in New Orleans. *Biol Sex Differ* [Internet]. 2021;12(1):20. Disponible en: <http://dx.doi.org/10.1186/s13293-021-00359-2>
- TeichVD, KlajnerS, AlmeidaFASde, DantasACB, LaselvaCR, Torritesi MG, et al. Epidemiologic and clinical features of patients with COVID-19 in Brazil. *Einstein (Sao Paulo)* [Internet]. 2020;18:eAO6022. Disponible en: http://dx.doi.org/10.31744/einstein_journal/2020ao6022
- Vial MR, Peters A, Pérez I, Spencer-Sandino M, Barbé M, Porte L, et al. Covid-19 in South America: clinical and epidemiological characteristics among 381 patients during the early phase of the pandemic in Santiago, Chile. *BMC Infect Dis* [Internet]. 2020;20(1):955. Disponible en: <http://dx.doi.org/10.1186/s12879-020-05665-5>
- Lendorf ME, Boisen MK, Kristensen PL, Løkkegaard ECL, Krog SM, Brandt L, et al. Characteristics and early outcomes of patients hospitalised for COVID-19 in North Zealand, Denmark. *Dan Med J*. 2020;67(9)
- Gao Y-D, Ding M, Dong X, Zhang J-J, Kursat Azkur A, Azkur D, et al. Risk factors for severe and critically ill COVID-19 patients: A review. *Allergy* [Internet]. 2021;76(2):428-55. Disponible en: <http://dx.doi.org/10.1111/all.14657>
- Xiong S, Liu L, Lin F, Shi J, Han L, Liu H, et al. Clinical characteristics of 116 hospitalized patients with COVID-19 in Wuhan, China: a single-centered, retrospective, observational study. *BMC Infect Dis* [Internet]. 2020;20(1):787. Disponible en: <http://dx.doi.org/10.1186/s12879-020-05452-2>
- Salacup G, Lo KB, Gul F, Peterson E, De Joy R, Bhargav R, et al. Characteristics and clinical outcomes of COVID-19 patients in an underserved-inner city population: A single tertiary center cohort. *J Med Virol* [Internet]. 2021;93(1):416-23. Disponible en: <http://dx.doi.org/10.1002/jmv.26252>
- Jiménez E, Fontán-Vela M, Valencia J, Fernandez-Jimenez I, Álvaro-Alonso EA, Izquierdo-García E, et al. Characteristics, complications and outcomes among 1549 patients hospitalised with COVID-19 in a secondary hospital in Madrid, Spain: a retrospective case series study. *BMJ Open* [Internet]. 2020;10(11):e042398. Disponible en: <http://dx.doi.org/10.1136/bmjopen-2020-042398>
- Petrilli CM, Jones SA, Yang J, Rajagopalan H, O'Donnell L, Chernyak Y, et al. Factors associated with hospital admission and critical illness among 5279 people with coronavirus disease 2019 in New York City: prospective cohort study. *BMJ* [Internet]. 2020;369:m1966. Disponible en: <http://dx.doi.org/10.1136/bmj.m1966>
- Gregoriano C, Koch D, Haubitz S, Conen A, Fux CA, Mueller B, et al. Characteristics, predictors and outcomes among 99 patients hospitalised with COVID-19 in a tertiary care centre in Switzerland: an observational analysis. *Swiss Med Wkly* [Internet]. 2020;150:w20316. Disponible en: <http://dx.doi.org/10.4414/sm.w.2020.20316>
- Hayden MR. Endothelial activation and dysfunction in metabolic syndrome, type 2 diabetes and coronavirus disease 2019. *J Int Med Res* [Internet]. 2020;48(7):300060520939746. Disponible en: <http://dx.doi.org/10.1177/0300060520939746>

26. Sattar N, McInnes IB, McMurray JJV. Obesity is a risk factor for severe COVID-19 infection: Multiple potential mechanisms: Multiple potential mechanisms. *Circulation* [Internet]. 2020;142(1):4-6. Disponible en: <http://dx.doi.org/10.1161/CIRCULATIONAHA.120.047659>
27. Casas-Rojo JM, Antón-Santos JM, Millán-Núñez-Cortés J, Lumbreras-Bermejo C, Ramos-Rincón JM, Roy-Vallejo E, et al. Características clínicas de los pacientes hospitalizados con COVID-19 en España: resultados del Registro SEMI-COVID-19. *Rev Clin Esp (Barc)* [Internet]. 2020;220(8):480-94. Disponible en: <http://dx.doi.org/10.1016/j.rce.2020.07.003>
28. Zhang J-J, Dong X, Cao Y-Y, Yuan Y-D, Yang Y-B, Yan Y-Q, et al. Clinical characteristics of 140 patients infected with SARS-CoV-2 in Wuhan, China. *Allergy* [Internet]. 2020;75(7):1730-41. Disponible en: <http://dx.doi.org/10.1111/all.14238>
29. Abraha HE, Gessesse Z, Gebrecherkos T, Kebede Y, Weldegiargis AW, Tequare MH, et al. Clinical features and risk factors associated with morbidity and mortality among patients with COVID-19 in northern Ethiopia. *Int J Infect Dis* [Internet]. 2021;105:776-83. Disponible en: <http://dx.doi.org/10.1016/j.ijid.2021.03.037>
30. Popov GT, Baymakova M, Vaseva V, Kundurzhiev T, Mutaftchiyski V. Clinical characteristics of hospitalized patients with COVID-19 in Sofia, Bulgaria. *Vector Borne Zoonotic Dis* [Internet]. 2020;20(12):910-5. Disponible en: <http://dx.doi.org/10.1089/vbz.2020.2679>
31. Pouw N, van de Maat J, Veerman K, Ten Oever J, Janssen N, Abbink E, et al. Clinical characteristics and outcomes of 952 hospitalized COVID-19 patients in The Netherlands: A retrospective cohort study. *PLoS One* [Internet]. 2021;16(3):e0248713. Disponible en: <http://dx.doi.org/10.1371/journal.pone.0248713>
32. He X, Yao F, Chen J, Wang Y, Fang X, Lin X, et al. The poor prognosis and influencing factors of high D-dimer levels for COVID-19 patients. *Sci Rep* [Internet]. 2021;11(1):1830. Disponible en: <http://dx.doi.org/10.1038/s41598-021-81300-w>
33. Ghweil AA, Hassan MH, Khodeary A, Mohamed AO, Mohammed HM, Abdelazez AA, et al. Characteristics, outcomes and indicators of severity for COVID-19 among sample of ESNA quarantine hospital's patients, Egypt: A retrospective study. *Infect Drug Resist* [Internet]. 2020;13:2375-83. Disponible en: <http://dx.doi.org/10.2147/IDR.S263489>
34. Chen R, Sang L, Jiang M, Yang Z, Jia N, Fu W, et al. Longitudinal hematologic and immunologic variations associated with the progression of COVID-19 patients in China. *J Allergy Clin Immunol* [Internet]. 2020;146(1):89-100. Disponible en: <http://dx.doi.org/10.1016/j.jaci.2020.05.003>
35. Asghar MS, Haider Kazmi SJ, Ahmed Khan N, Akram M, Ahmed Khan S, Rasheed U, et al. Clinical profiles, characteristics, and outcomes of the first 100 admitted COVID-19 patients in Pakistan: A single-center retrospective study in a tertiary care hospital of Karachi. *Cureus* [Internet]. 2020;12(6):e8712. Disponible en: <http://dx.doi.org/10.7759/cureus.8712>
36. Chen G, Wu D, Guo W, Cao Y, Huang D, Wang H, et al. Clinical and immunological features of severe and moderate coronavirus disease 2019. *J Clin Invest* [Internet]. 2020;130(5):2620-9. Disponible en: <http://dx.doi.org/10.1172/JCI137244>
37. Lim AYH, Goh JL, Chua MCW, Heng BH, Abisheganaden JA, George PP. Temporal changes of haematological and radiological findings of the COVID-19 infection-a review of literature. *BMC Pulm Med* [Internet]. 2021;21(1):37. Disponible en: <http://dx.doi.org/10.1186/s12890-020-01389-z>

Correlation between overweight and obesity scales and blood pressure values in 418.343 Spanish workers

Correlación entre las escalas de sobrepeso y obesidad y los valores de presión arterial en 418.343 trabajadores españoles

Angel Arturo López-González¹ , Pilar Tomás-Gil¹ , Josep Lluís Coll Villalonga¹ ,
Pau Martí- Lliteras¹ , Hilda María González San Miguel¹ ,
José Ignacio Ramírez-Manent^{1,2,3} 

1. ADEMA-Health group of IUNICS. University Balearic Islands

2. Faculty of Medicine, University Balearic Islands

3. IDISBA, Balearic Islands Health Research Institute Foundation

Corresponding author

Josep Lluís Coll Villalonga

E-mail: joseplluiscoll@redfarma.org

Received: 18 - XII - 2022

Accepted: 12 - I - 2023

doi: 10.3306/AJHS.2023.38.03.44

Abstract

Objective: One of the objectives of a health system is to be able to identify people with high blood pressure and achieve a good control of them in order to avoid future complications and reduce cardiovascular morbidity and mortality. For this reason, the aim of this study was to determine the relationship between blood pressure and different overweight and obesity scales, some of which include the estimation of body fat.

Methods: A retrospective, cross-sectional study was conducted in 421625 Spanish workers. Anthropometric, clinical, and analytical measurements were carried out after standardizing the measurement techniques. Several overweight and obesity scales were analyzed: Visceral adiposity index (VAI), dysfunctional adiposity index, a body shape index (ABSI), normalized weight-adjusted index (NWA), conicity index, body mass index (BMI), and also other formulas to estimate the percentage of body fat. A descriptive analysis of the categorical variables was performed.

Results: The results show higher values in the indicators of overweight and obesity in the group of patients with hypertension compared to the group of non-hypertensive patients for both sexes. Values of the anthropometric measurements and clinical parameters, as well as the different scales of overweight and obesity, had more unfavorable results in the group of men, favoring the appearance of arterial hypertension, while patients with normal weight tended to have better blood pressure levels. It was also seen that the older the age, the greater the risk of presenting altered blood pressure rates in both sexes.

Conclusions: The study shows in a statistically significant way that overweight and obese patients have a greater risk of presenting arterial hypertension in both sexes, with an increased risk at an older age, so it is vitally important to influence lifestyle modifications, in order to reduce morbidity and mortality due to different pathologies deriving from overweight, obesity, and hypertension.

Key words: Obesity, Hipertensión, Body mass index.

Resumen

Objetivo: Uno de los objetivos de un sistema sanitario es poder identificar a las personas con hipertensión arterial y lograr un buen control de las mismas para evitar futuras complicaciones y reducir la morbilidad y mortalidad cardiovascular. Por ello, el objetivo de este estudio fue determinar la relación entre la presión arterial y diferentes escalas de sobrepeso y obesidad, algunas de las cuales incluyen la estimación de la grasa corporal.

Métodos: Se realizó un estudio retrospectivo y transversal en 421625 trabajadores españoles. Se realizaron mediciones antropométricas, clínicas y analíticas tras estandarizar las técnicas de medición. Se analizaron varias escalas de sobrepeso y obesidad: Índice de adiposidad visceral (VAI), índice de adiposidad disfuncional, índice de forma corporal (ABSI), índice normalizado ajustado al peso (NWA), índice de conicidad, índice de masa corporal (IMC) y también otras fórmulas para estimar el porcentaje de grasa corporal. Se realizó un análisis descriptivo de las variables categóricas.

Resultados: Los resultados muestran valores más altos en los indicadores de sobrepeso y obesidad en el grupo de pacientes con hipertensión en comparación con el grupo de pacientes no hipertensos para ambos sexos. Los valores de las medidas antropométricas y los parámetros clínicos, así como las diferentes escalas de sobrepeso y obesidad, tuvieron resultados más desfavorables en el grupo de hombres, favoreciendo la aparición de hipertensión arterial, mientras que los pacientes con peso normal tendieron a tener mejores niveles de presión arterial. También se observó que a mayor edad, mayor es el riesgo de presentar índices de presión arterial alterados en ambos sexos.

Conclusiones: El estudio muestra de forma estadísticamente significativa que los pacientes con sobrepeso y obesidad tienen un mayor riesgo de presentar hipertensión arterial en ambos sexos, con un riesgo mayor a mayor edad, por lo que es de vital importancia incidir en las modificaciones del estilo de vida, con el fin de reducir la morbilidad y mortalidad por las diferentes patologías derivadas del sobrepeso, la obesidad y la hipertensión.

Palabras clave: Obesidad, Hipertensión arterial, índice de masa corporal.

Introduction

High blood pressure levels are associated with an increased risk of cardiovascular morbidity and mortality^{1,2} so if these levels can be reduced, the mortality rate and the risk of suffering cardiovascular events can also be significantly reduced³. For this reason, one of the most important objectives of a health system is to be able to identify people with high blood pressure and achieve good control of them in order to avoid future complications.

In Spain, the prevalence of arterial hypertension is high, and the degree of knowledge and control is lower than in neighboring countries and in the United States⁴⁻⁶, with the negative medical and economic implications that this entails.

Many risk factors have been associated with hypertension, some of which are considered to be nonmodifiable, including family history^{7,8}, and male sex, although the figures are very high in menopausal women⁹, and black race¹⁰. Among the modifiable risk factors¹¹⁻¹³ are excessive consumption of alcohol, caffeine, sodium, potassium, sedentary lifestyle, and tobacco use. A modifiable factor closely related to hypertension is obesity, and 60-70% of hypertension in adults has been estimated to be related to this increase in weight¹⁴. Many mechanisms are known to be involved in the genesis of hypertension in obese individuals, including insulin resistance, sodium retention, increased activity of the sympathetic nervous system, activation of the renin-angiotensin-aldosterone axis, and altered vascular function¹⁴. However, the relationship between excess weight and arterial hypertension has some nuances, since excess body mass does not always really indicate obesity. For this reason, body fat distribution can be important in such a way that centripetal obesity is associated with more lipid disorders^{15,16}.

The aim of this study was therefore to assess the relationship between blood pressure and different overweight and obesity scales, some of which include the estimation of body fat.

Materials and methods

Study design

A retrospective, cross-sectional study was conducted in 421.625 Spanish workers between January 2019 and June 2020, selected based on their attendance to periodic occupational medical examinations.

Inclusion criteria:

- Belonging to one of the participating companies.
- Agreeing to participate in the study and consenting to the use of the data for epidemiological purposes.

- Not under 18 years of age and not over 69 years of age.
- Having the parameters to calculate overweight or obesity scales or the presence of hypertension.

The workers finally included in the study and reasons for exclusion are presented in the flow chart. (see **figure 1**).

Figure 1: Participant flow chart.

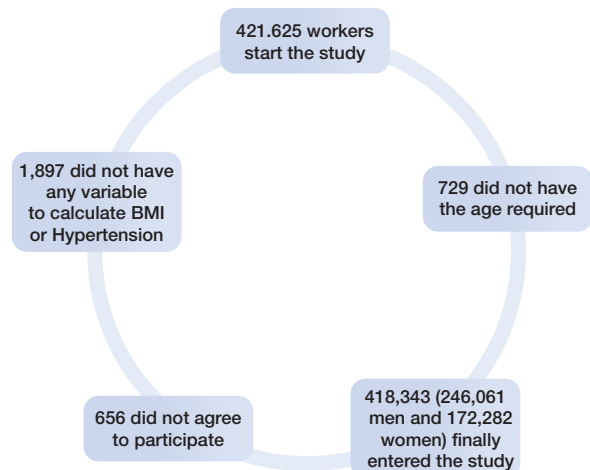

Anthropometric, clinical, and analytical measurements were carried out by the healthcare professionals of the different occupational health units that participated in the study, after standardizing the measurement techniques.

Glycemia, total cholesterol, and triglycerides were determined by automated enzymatic methods and HDL by precipitation with dextran sulfate Cl2Mg. LDL was calculated using the Friedewald formula (provided that triglycerides were less than 400 mg/dl). All the above values are expressed in mg/dl.

Friedewald's formula: $LDL = \text{total cholesterol} - HDL - \text{triglycerides}/5$

To measure weight (in kilograms) and height (in cm), a height bar scale (model: SECA 700) with an added SECA 220 telescopic height bar was used.

Abdominal waist circumference was measured in cm with a tape measure, using the SECA model 20, with an interval of 1-200 cm and millimeter division. For this, the individual was measured in a standing position, feet together and trunk erect, abdomen relaxed, and upper extremities hanging on both sides of the body. The tape measure was then placed parallel to the ground at the level of the last floating rib.

The overweight and obesity indexes analyzed include:

- Visceral adiposity index¹⁷ (VAI)

Males:

$$VAI = \left(\frac{WC}{39,68 + (1,88 \times BMI)} \right) \times \left(\frac{TG}{1,03} \right) \times \left(\frac{1,31}{HDL} \right)$$

Females:

$$VAI = \left(\frac{WC}{36,58 + (1,89 \times BMI)} \right) \times \left(\frac{TG}{0,81} \right) \times \left(\frac{1,52}{HDL} \right)$$

- Dysfunctional adiposity index¹⁸
 $[WC/[22.79 + [2.68 \times BMI]]] \times [TG, \text{mmol/L}/1.37] \times [1.19/\text{high density lipoprotein-cholesterol (HDL-C, mmol/L)}]$ for males, and $[WC/[24.02 + [2.37 \times BMI]]] \times [TG(\text{mmol/L})/1.32] \times [1.43/\text{HDL-C}(\text{mmol/L})]$ for females.

- A body shape index (ABSI)¹⁹.

$$ABSI = \frac{WC}{BMI^{2/3} \times \text{height}^{1/2}}$$

- Normalized weight-adjusted index (NWAJ)²⁰
 $[(\text{weight}/10) - (10 \times \text{height}) + 10]$ with weight measured in kg and height in m.

- Conicity index²¹

$$\frac{\text{waist circumference (in metres)}}{0,109} \times 1 \sqrt{\frac{\text{Weight (in kilogram)}}{\text{Height (in metres)}}$$

- Body Roundness Index²² (BRI)

$$BRI = 364,2 - 365,5 \times \sqrt{1 - \frac{WC/(2\pi)^2}{(0,5 \text{ height})^2}}$$

- Body mass index (BMI) was calculated by dividing weight by height in squared meters. and was classified according to SEEDO criteria²³.

- Body mass index modified²⁴
 $BMI = 1.3(\text{weight in kg}) / (\text{height in m})^{2.5}$

- The waist-to-height ratio was considered risky over 0.50²⁵.

- The body surface index²⁶ (BSA) was calculated from the body surface area (BSA)

$$BSA = w^{0,425} \times h^{0,725} \times 0,007184$$

where w represents weight in kg and h height in cm

$$BSI = \frac{WEIGHT}{\sqrt{BSA}}$$

Formulas to estimate the percentage of body fat:

- Relative fat mass²⁷ $76 - (20 \times (\text{height}/\text{p waist}))$ Height and waist circumference are expressed in meters.

- CUN BAE²⁸ (University of Navarra Body Adiposity Estimator Clinic)

$$-44.988 + (0.503 \times \text{age}) + (10.689 \times \text{sex}) + (3.172 \times \text{BMI}) - (0.026 \times \text{BMI}^2) + (0.181 \times \text{BMI} \times \text{sex}) - (0.02 \times \text{BMI} \times \text{age}) - (0.005 \times \text{BMI}^2 \times \text{sex}) + (0.00021 \times \text{BMI}^2 \times \text{age})$$

- ECORE-BF (Equation COrdoba Estimator Body Fat)²⁹

$$-97.102 + 0.123 (\text{age}) + 11.9 (\text{gender}) + 35.959 (\text{LnBMI})$$

In CUN BAE and ECORE-BF, male is 0 and female 1, and cut-off points for obesity are 35% in women 25% in men.

- Palafolls formula³⁰.

$$\text{Men} = (\text{BMI}/\text{waist}] \times 10) + \text{BMI}. \text{Women} = (\text{BMI}/\text{waist}] \times 10) + \text{BMI} + 10.$$

- Deurenberg formula³¹.

$$1.2 \times (\text{BMI}) + 0.23 \times (\text{age}) - 10.8 \times (\text{gender}) - 5.4$$

Male = 0 Female = 1

Blood pressure was measured with a calibrated OMRON M3 automatic sphygmomanometer after 10 minutes of rest. Three measurements were taken at one-minute intervals, obtaining the mean value of the three. JNC-7 criteria were used to classify blood pressure³².

An individual was considered a smoker if s/he had regularly consumed at least 1 cigarette/day (or the equivalent in other types of consumption) in the previous month or had quit smoking less than 12 months before.

Statistical analysis

A descriptive analysis of the categorical variables was carried out, calculating the frequency and distribution of responses for each of them. For quantitative variables, the mean and standard deviation were calculated, whereas for qualitative variables the percentage was calculated. A bivariate association analysis was performed using the χ^2 test (with a correction with the Fisher's exact statistical test, when conditions required so) and a Student's t-test for independent samples. For the multivariate analysis, binary logistic regression was used with the Wald method, the calculation of the Odds-ratio, and the Hosmer-Lemeshow goodness-of-fit test. Statistical analysis was performed with the SPSS 27.0 program, and a p value of <0.05 was considered as statistically significant.

Considerations and ethical aspects

The study was approved by the Clinical Research Ethics Committee of the Health Area of the Balearic Islands (n° IB 4383/20). All procedures were performed in accordance with the ethical standards of the institutional research committee and with the 2013 Declaration of Helsinki. All patients signed written informed consent documents prior to participation in the study.

Results

The mean values of the anthropometric and clinical parameters and also the parameters from the overweight and obesity scales are higher in men, while parameters that estimate body fat are higher in women. In all cases, as shown in **table I**, the differences are statistically significant between both sexes. All data are presented in **table I**.

The mean values of all the overweight and obesity indicators are higher in the hypertensive group compared with non-hypertensive individuals. This situation is repeated in both sexes. Differences between both groups are statistically significant in all cases. The group of hypertensive patients in both sexes is also observed to have a higher mean age. Complete data are presented in **table II**.

Table III shows the degree of relationship between systolic blood pressure (SBP), diastolic blood pressure (DPB), and the different scales that assess overweight and obesity. In all cases, except with the body shape index, there is a positive correlation. The highest degree of correlation in both sexes and for both SBP and DBP is with the Deurenberg formula.

Table I: Baseline characteristics and anthropometric measurements and indices in the study population.

	Male n=246061 Mean (SD)	Female n=172282 Mean (SD)	Total n=418343 Mean (SD)	p-value
Age (years)	40.57 (11.06)	39.58 (10.78)	40.16 (10.96)	<0.0001
Systolic blood pressure (mmHg)	128.17 (15.53)	117.43 (15.66)	123.74 (16.45)	<0.0001
Diastolic blood pressure (mmHg)	77.75 (10.96)	72.59 (10.40)	75.62 (11.03)	<0.0001
Waist circumference (cm)	86.16 (11.09)	74.77 (10.55)	81.47 (12.23)	<0.0001
Body mass index (kg/m ²)	26.67 (4.46)	25.29 (5.15)	26.10 (4.81)	<0.0001
Body mass index modified (kg/m ²)	26.26 (4.47)	25.88 (5.36)	26.10 (4.86)	<0.0001
Waist to height ratio	0.49 (0.06)	0.46 (0.06)	0.48 (0.06)	<0.0001
Body surface area	1.96 (0.18)	1.70 (0.17)	1.85 (0.22)	<0.0001
Body surface index	57.84 (7.87)	50.52 (8.08)	54.82 (8.73)	<0.0001
Normalized weight-adjusted index	0.67 (1.37)	0.44 (1.37)	0.58 (1.37)	<0.0001
Body roundness index	3.31 (1.17)	2.76 (1.20)	3.08 (1.21)	<0.0001
Body shape index (m ^{7/6} /kg ^{2/3})	0.074 (0.006)	0.069 (0.006)	0.072 (0.006)	<0.0001
Visceral adiposity index	7.39 (6.48)	2.71 (1.65)	5.46 (5.58)	<0.0001
Dysfunctional adiposity index	0.91 (0.73)	0.69 (0.41)	0.82 (0.63)	<0.0001
Conicity index (m ^{2/3} /kg ^{1/2})	1.16 (0.09)	1.08 (0.09)	1.13 (0.10)	<0.0001
CUN BAE (%)	25.48 (6.62)	35.17 (7.14)	29.50 (8.34)	<0.0001
ECORE-BF (%)	25.48 (6.30)	35.15 (7.27)	29.46 (8.23)	<0.0001
Relative fat mass (%)	22.87 (4.99)	31.98 (5.55)	26.62 (6.89)	<0.0001
Deurenberg formula (%)	25.13 (6.49)	34.06 (7.11)	28.81 (8.05)	<0.0001
Palafolls formula (%)	29.76 (4.68)	38.67 (5.46)	33.43 (6.66)	<0.0001

Table II: Comparison of anthropometric indices in hypertensive and non-hypertensive population.

	Men			Women		
	n=175224	n=70837		n=148962	n=23320	
	Non-Hypertension	Hypertension	p-value	Non-Hypertension	Hypertension	p-value
Age (years)	38.50 (10.58)	45.70 (10.53)	<0.0001	38.31 (10.36)	47.66 (9.88)	<0.0001
Waist circumference (cm)	84.63 (10.47)	89.94 (11.64)	<0.0001	73.98 (9.97)	79.86 (12.58)	<0.0001
Body mass index (kg/m ²)	25.80 (3.99)	28.79 (4.84)	<0.0001	24.76 (4.79)	28.72 (6.00)	<0.0001
Body mass index modified (kg/m ²)	25.39 (4.00)	28.39 (4.83)	<0.0001	25.31 (4.98)	29.49 (6.22)	<0.0001
Waist to height ratio	0.48 (0.06)	0.52 (0.06)	<0.0001	0.46 (0.06)	0.50 (0.08)	<0.0001
Body surface area	1.94 (0.17)	2.02 (0.19)	<0.0001	1.69 (0.16)	1.77 (0.19)	<0.0001
Body surface index	56.47 (7.18)	61.23 (8.46)	<0.0001	49.77 (7.60)	55.33 (9.35)	<0.0001
Normalized weight-adjusted index	0.41 (1.23)	1.33 (1.48)	<0.0001	0.30 (0.28)	1.36 (1.57)	<0.0001
Body roundness index	3.13 (1.07)	3.75 (1.28)	<0.0001	2.65 (1.10)	3.42 (1.51)	<0.0001
Body shape index (m ^{7/6} /kg ^{2/3})	0.074 (0.006)	0.073 (0.006)	<0.0001	0.068 (0.006)	0.069 (0.006)	<0.0001
Visceral adiposity index	6.51 (5.42)	9.59 (8.15)	<0.0001	2.58 (1.51)	3.53 (2.20)	<0.0001
Dysfunctional adiposity index	0.83 (0.63)	1.12 (0.90)	<0.0001	0.66 (0.38)	0.88 (0.54)	<0.0001
Conicity index (m ^{2/3} /kg ^{1/2})	1.16 (0.09)	1.17 (0.09)	<0.0001	1.07 (0.09)	1.08 (0.09)	<0.0001
CUN BAE (%)	24.05 (6.19)	28.99 (6.32)	<0.0001	34.34 (6.82)	40.53 (6.78)	<0.0001
ECORE-BF (%)	24.11 (5.85)	28.87 (6.09)	<0.0001	34.29 (6.87)	40.66 (7.31)	<0.0001
Relative fat mass (%)	22.12 (4.86)	24.71 (4.81)	<0.0001	31.52 (5.35)	34.91 (5.89)	<0.0001
Deurenberg formula (%)	23.62 (5.86)	28.86 (6.47)	<0.0001	33.12 (6.58)	40.03 (7.45)	<0.0001
Palafolls formula (%)	28.86 (4.20)	32.00 (5.06)	<0.0001	38.10 (5.08)	42.31 (6.28)	<0.0001

Table III: Pearson correlation of individual anthropometric indices with blood pressure stratified by sex.

	Men n=246061				Women n=172282			
	SBP		DBP		SBP		DBP	
	Pearson	p-value	Pearson	p-value	Pearson	p-value	Pearson	p-value
Waist circumference (cm)	0.222	<0.0001	0.231	<0.0001	0.248	<0.0001	0.229	<0.0001
Body mass index (kg/m ²)	0.327	<0.0001	0.354	<0.0001	0.341	<0.0001	0.318	<0.0001
Body mass index modified (kg/m ²)	0.325	<0.0001	0.354	<0.0001	0.341	<0.0001	0.317	<0.0001
Waist to height ratio	0.240	<0.0001	0.256	<0.0001	0.269	<0.0001	0.247	<0.0001
Body surface area	0.234	<0.0001	0.244	<0.0001	0.257	<0.0001	0.242	<0.0001
Body surface index	0.304	<0.0001	0.326	<0.0001	0.321	<0.0001	0.302	<0.0001
Normalized weight-adjusted index	0.325	<0.0001	0.355	<0.0001	0.339	<0.0001	0.317	<0.0001
Body roundness index	0.242	<0.0001	0.256	<0.0001	0.269	<0.0001	0.249	<0.0001
Body shape index (m ^{7/6} /kg ^{2/3})	-0.088	<0.0001	-0.109	<0.0001	-0.117	<0.0001	-0.115	<0.0001
Visceral adiposity index	0.213	<0.0001	0.250	<0.0001	0.213	<0.0001	0.204	<0.0001
Dysfunctional adiposity index	0.177	<0.0001	0.216	<0.0001	0.199	<0.0001	0.191	<0.0001
Conicity index (m ^{2/3} /kg ^{1/2})	0.022	<0.0001	0.011	<0.0001	0.015	<0.0001	0.007	<0.0001
CUN BAE (%)	0.356	<0.0001	0.409	<0.0001	0.385	<0.0001	0.357	<0.0001
ECORE-BF (%)	0.360	<0.0001	0.411	<0.0001	0.385	<0.0001	0.356	<0.0001
Relative fat mass (%)	0.231	<0.0001	0.249	<0.0001	0.260	<0.0001	0.236	<0.0001
Deurenberg formula (%)	0.377	<0.0001	0.440	<0.0001	0.411	<0.0001	0.379	<0.0001
Palafolls formula (%)	0.328	<0.0001	0.357	<0.0001	0.342	<0.0001	0.320	<0.0001

Area under the ROC curves (AUC) of the anthropometric indices to predict hypertension. The area under the ROC curve (AUC) for each anthropometric index and hypertension is shown in the **table IV**.

The figure shows the gender-specific ROC curves of the anthropometric indices for predicting hypertension. The AUCs of all anthropometric indices were greater than 0.5 (p <0.001) suggesting predictive significance except for Body Shape Index.

In general, the Deurenberg formula and CUN-BAE showed the highest AUC of over 0.7 for systolic hypertension in both sexes and also for diastolic hypertension in women, whereas diastolic hypertension values in men had a higher AUC for Body Mass Index (0.716).

In both sexes and in both systolic and diastolic hypertension, the values with the lowest AUC were those of the ABSI with a mean of 0.400.

The derived gender specific optimal cut-off points of each anthropometric index that best balanced sensitivity and specificity for systolic and diastolic hypertension are shown in **table V**.

In males, NWA and Deurenberg formula had the highest sensitivities of 67.3% and 67.7% each for systolic hypertension, while the Deurenberg formula was the most sensitive (72.5%) for diastolic hypertension. As can be seen in the table, the Youden index also presented higher values for the Deurenberg formula (33.0).

In women, CUN-BAE and the Deurenberg formula were more sensitive in systolic and diastolic hypertension and also the ECOPE-BF.

ABSI was the least sensitive but most specific for systolic and diastolic hypertension in both sexes but with a low Youden index, which indicates that it would not be the best parameter for interpretation in terms of specificity and sensitivity.

Table IV: AUCs of anthropometric indices for diagnosing hypertension.

	Men						Women					
	Systolic hypertension			Diastolic hypertension			Systolic hypertension			Diastolic hypertension		
	AUC	95% CI	p-value	AUC	95% CI	p-value	AUC	95% CI	p-value	AUC	95% CI	p-value
Waist circumference (cm)	0.617	0.614-0.620	<0.0001	0.675	0.672-0.678	<0.0001	0.635	0.630-0.641	<0.0001	0.646	0.639-0.653	<0.0001
Body mass index (kg/m ²)	0.681	0.678-0.684	<0.0001	0.716	0.713-0.718	<0.0001	0.712	0.707-0.717	<0.0001	0.710	0.704-0.716	<0.0001
Body mass index modified (kg/m ²)	0.682	0.679-0.685	<0.0001	0.707	0.705-0.710	<0.0001	0.716	0.711-0.720	<0.0001	0.711	0.705-0.716	<0.0001
Waist to height ratio	0.632	0.629-0.635	<0.0001	0.674	0.671-0.677	<0.0001	0.660	0.655-0.665	<0.0001	0.662	0.656-0.669	<0.0001
Body surface area	0.616	0.613-0.619	<0.0001	0.680	0.677-0.683	<0.0001	0.632	0.627-0.637	<0.0001	0.650	0.643-0.656	<0.0001
Body surface index	0.661	0.658-0.664	<0.0001	0.713	0.710-0.716	<0.0001	0.686	0.681-0.691	<0.0001	0.693	0.687-0.700	<0.0001
Normalized weight-adjusted index	0.682	0.679-0.684	<0.0001	0.712	0.710-0.715	<0.0001	0.715	0.710-0.720	<0.0001	0.710	0.704-0.716	<0.0001
Body roundness index	0.632	0.629-0.635	<0.0001	0.675	0.672-0.678	<0.0001	0.660	0.655-0.666	<0.0001	0.663	0.656-0.669	<0.0001
Body shape index m ^{7/6} /kg ^{2/3}	0.451	0.448-0.454	<0.0001	0.491	0.488-0.494	<0.0001	0.418	0.413-0.424	<0.0001	0.433	0.427-0.440	<0.0001
Visceral adiposity index	0.649	0.646-0.651	<0.0001	0.708	0.705-0.711	<0.0001	0.663	0.658-0.668	<0.0001	0.663	0.656-0.669	<0.0001
Dysfunctional adiposity index	0.625	0.622-0.628	<0.0001	0.668	0.665-0.671	<0.0001	0.653	0.648-0.658	<0.0001	0.654	0.647-0.660	<0.0001
Conicity index (m ^{2/3} /kg ^{1/2})	0.513	0.510-0.516	<0.0001	0.565	0.561-0.568	<0.0001	0.503	0.498-0.509	0.210	0.519	0.512-0.526	<0.0001
CUN BAE (%)	0.704	0.702-0.707	<0.0001	0.620	0.617-0.623	<0.0001	0.749	0.745-0.754	<0.0001	0.734	0.729-0.740	<0.0001
ECORE-BF (%)	0.706	0.703-0.708	<0.0001	0.620	0.617-0.623	<0.0001	0.747	0.743-0.751	<0.0001	0.733	0.727-0.739	<0.0001
Relative fat mass (%)	0.632	0.629-0.635	<0.0001	0.532	0.529-0.535	<0.0001	0.660	0.655-0.666	<0.0001	0.663	0.656-0.669	<0.0001
Palafolls formula (%)	0.682	0.680-0.685	<0.0001	0.573	0.570-0.577	<0.0001	0.714	0.709-0.719	<0.0001	0.711	0.705-0.717	<0.0001
Deurenberg formula (%)	0.720	0.717-0.723	<0.0001	0.644	0.641-0.647	<0.0001	0.774	0.770-0.778	<0.0001	0.750	0.745-0.756	<0.0001

Table V: ROC determined cut-off, sensitivity, and specificity of each anthropometric index for predicting hypertension.

	Systolic hypertension				Diastolic hypertension			
	Cut-off	Sensitivity (%)	Specificity (%)	Youden index	Cut-off	Sensitivity (%)	Specificity (%)	Youden index
Men								
Waist circumference (cm)	86.00	61.1	55.5	16.6	86.00	63.5	54.7	18.2
Body mass index (kg/m ²)	27.00	63.4	63.1	26.5	27.30	65.4	64.6	30.0
Body mass index modified (kg/m ²)	26.50	64.3	62.5	26.8	26.9	65.4	64.8	30.2
Waist to height ratio	0.50	60.9	58.1	19.0	0.50	61.3	59.8	21.1
Body surface area	1.97	58.9	57.6	16.5	1.97	61.9	56.9	18.8
Body surface index	58.00	63.7	59.4	23.1	58.50	63.3	61.1	24.4
Normalized weight-adjusted index	0.70	67.3	62.0	29.3	0.85	66.2	64.0	30.2
Body roundness index	3.30	60.8	58.2	19.0	3.35	62.1	58.9	21.0
Body shape index m ^{7/6} /kg ^{2/3}	0.0722	51.3	41.9	-6.8	0.0724	48.0	45.9	-6.1
Visceral adiposity index	6.00	63.5	58.5	22.0	6.00	68.0	57.6	25.6
Dysfunctional adiposity index	0.76	60.5	58.6	19.1	0.80	61.2	60.3	21.5
Conicity index (m ^{2/3} /kg ^{1/2})	1.15	54.5	47.4	1.9	1.16	51.0	50.6	1.6
CUN BAE (%)	26.90	65.3	65.0	30.3	26.90	70.5	63.6	34.1
ECORE-BF (%)	26.86	65.3	65.2	30.5	27.0	69.7	64.6	34.3
Relative fat mass (%)	23.75	60.8	58.2	19.0	23.75	63.6	57.2	20.8
Deurenberg formula (%)	26.30	67.7	65.3	33.0	26.40	72.5	64.5	37.0
Palafolls formula (%)	30.00	64.5	62.2	26.7	30.00	69.2	60.9	30.1
Women								
Waist circumference (cm)	74.00	64	55.1	19.1	74.00	65.8	54.7	20.5
Body mass index (kg/m ²)	25.7	67.7	63.6	31.3	26.00	66.2	65	31.2
Body mass index modified (kg/m ²)	26.60	66.1	65.9	32	26.60	66.4	65.1	31.5
Waist to height ratio	0.47	63	61.1	24.1	0.47	63.7	60.5	24.2
Body surface area	1.71	60.3	59	19.3	1.72	61	60.8	21.8
Body surface index	51.00	65.7	61.7	27.4	51.70	64.3	64.3	28.6
Normalized weight-adjusted index	0.62	66.4	65.5	31.9	0.62	66.7	64.7	31.4
Body roundness index	2.74	62.7	61.4	24.1	2.74	63.5	60.8	24.3
Body shape index m ^{7/6} /kg ^{2/3}	0.0677	45.2	42.9	-11.9	0.0677	53.6	46.9	0.5
Visceral adiposity index	2.55	63.6	60	23.6	2.55	64.3	59.4	23.7
Dysfunctional adiposity index	0.66	61.6	60.6	22.2	0.66	62.5	60.1	22.6
Conicity index (m ^{2/3} /kg ^{1/2})	1.07	50.6	49.9	0.5	1.07	55.1	47.2	2.3
CUN BAE (%)	37.70	68.5	68.1	36.6	37.70	67.5	67.1	34.6
ECORE-BF (%)	37.60	68.2	68.2	36.4	37.60	67.5	67.1	34.6
Relative fat mass (%)	33.10	62.5	61.7	24.2	33.2	62.6	62.1	24.7
Deurenberg formula (%)	36.40	70.9	69.9	40.8	36.30	68.5	68.4	36.9
Palafolls formula (%)	39.40	66.2	65.4	31.6	39.40	66.9	64.4	31.3

Table VI: Logistic regression for independent determinants of hypertension (≥ 140/90 mmHg).

	Systolic Hypertension		Diastolic Hypertension		Hypertension	
	OR (95% CI)	p-value	OR (95% CI)	p-value	OR (95% CI)	p-value
Gender	3.006 (2.927-3.088)	<0.0001	3.002 (2.911-3.096)	<0.0001	2.956 (2.890-3.020)	<0.0001
Age	2.729 (2.671-2.788)	<0.0001	1.951 (1.902-2.001)	<0.0001	2.787 (2.737-2.838)	<0.0001
Waist circumference (cm)	1.564 (1.514-1.617)	<0.0001	1.558 (1.501-1.617)	<0.0001	1.419 (1.378-1.462)	<0.0001
Body mass index (kg/m ²)	1.646 (1.598-1.695)	<0.0001	1.622 (1.574-1.672)	<0.0001	1.624 (1.583-1.667)	<0.0001
Waist to height ratio	ns	ns	ns	ns	1.055 (1.025-1.086)	<0.0001
Body roundness index	ns	ns	ns	ns	ns	ns
Body shape index m ^{7/6} /kg ^{2/3}	0.860 (0.837-0.883)	<0.0001	0.807 (0.784-0.831)	<0.0001	0.944 (0.916-0.973)	<0.0001
Conicity index (m ^{2/3} /kg ^{1/2})	ns	ns	ns	ns	0.968 (0.938-0.999)	<0.0001
CUN BAE (%)	1.538 (1.480-1.598)	<0.0001	ns	ns	1.202 (1.092-1.324)	<0.0001
ECORE-BF (%)	ns	ns	1.531 (1.462-1.603)	<0.0001	1.266 (1.151-1.392)	<0.0001
Relative fat mass (%)	1.051 (1.021-1.081)	0.001	ns	ns	1.140 (1.109-1.172)	<0.0001
Deurenberg formula (%)	1.385 (1.331-1.441)	<0.0001	2.04 (1.942-2.146)	<0.0001	1.499 (1.454-1.545)	<0.0001
Palafolls formula (%)	1.459 (1.395-1.525)	<0.0001	1.345 (1.267-1.428)	<0.0001	1.444 (1.397-1.491)	<0.0001

In both sexes, the Deurenberg formula is the one with the highest Youden index, indicating greater specificity and sensitivity, followed by the CUN BAE and ECOPE-BF formulas.

The logistic regression model included as covariates: men, aged from 50 years, high waist and obesity indices and formulas. The systolic and diastolic blood pressure cut-off levels and the presence or absence of hypertension were analyzed to see their relationship with overweight and obesity. It was possible to objectify that the independent variables age and gender are those that are related to a greater probability of presenting altered values in both systolic and diastolic blood

pressure figures separately, as well as to the presence of hypertension.

Overweight and obesity indices and formulas also have a positive association with blood pressure values, except for the Body Shape Index, which has a low probability of altering blood pressure levels, with an OR <1.

The variables waist to height ratio, Body Roundness Index, chronicity index, and ECOPE-BF did not influence the values of systolic or diastolic pressure, but they did influence the presence of hypertension, except for the Body Roundness Index, which had no relationship with categorical variables. (See **table VI**).

Discussion

The obesity pandemic is a global problem. It is a cardiovascular risk factor that predisposes to the development of multiple pathologies that deteriorate the quality of life of every patient.

It directly contributes to the development of hypertension as demonstrated in the systematic review by Garcia Casillimas *et al.*¹⁴

The results in our study show higher values in the indicators of overweight and obesity in the group of patients with hypertension compared to the group of non-hypertensive patients for both sexes. The values of the anthropometric measurements, and clinical parameters, as well as the different scales of overweight and obesity, have more unfavorable results in the group of men.

There are non-modifiable variables (age, gender, personal history) that influence the appearance of high blood pressure values, so changes in lifestyle and reduction in overweight and obesity rates are very important so as to avoid future complications.

Hypertension is related to higher morbidity and mortality, so if its values are controlled, as well as other modifiable variables (alcohol consumption, obesity, sedentary lifestyle, tobacco...), cardiovascular risk and therefore morbidity and mortality from cardiovascular diseases could be reduced².

Over 60% of hypertensive patients are overweight or obese and if these variables as well as lifestyle are not modified, it will be difficult to achieve optimal blood pressure levels and a reduction in cardiovascular risk^{4,7}.

Several studies compare overweight and obesity rates in patients with diabetes mellitus, but there are few studies in the literature that compare obesity and overweight with high blood pressure^{22,24,25}, so this would be one of the strengths of our study, as well as its large sample size with 421.625 patients.

With the results obtained in this study, it is observed that most of the overweight and obesity parameters, as well as their scales, have worse results in the group of men, favoring the appearance of arterial hypertension, while patients with normal weight tend to have better blood pressure levels.

It has also been seen that the older the age, the greater the risk of presenting altered blood pressure rates in both sexes. Parameters such as body fat are more altered in the group of women.

It is important to note that not all excess fat is related to obesity, so its body distribution must be taken into account. For this reason, the Deurenberg formula has a high specificity and sensitivity with a greater degree of correlation and also the CUN-BAE formula. Scales such as ABSI are imprecise for estimating body fat at the individual level²⁸ and do not take into account the variables of age and gender, which are directly related to the presence of hypertension. All the results obtained are statistically significant.

The limitations found in this study are that it was carried out in a specific geographic area, with a Caucasian working population, which could limit the generalization of the results to other areas; hence the findings would not be applicable to other populations.

To conclude, the study shows in a statistically significant way that overweight and obese patients have a greater risk of presenting arterial hypertension in both sexes, with an increased risk at an older age, so it is vitally important to influence lifestyle modifications, in order to reduce morbidity and mortality due to different pathologies derived from overweight, obesity, and hypertension.

Conflict of interest

None

References

1. Chobanian AV, Bakris GL, Black HR, Cushman WC, Green LA, Izzo JL, et al. The seventh report of the Joint National Committee on Prevention, Detection, Evaluation, and Treatment of High Blood Pressure: The JNC 7 report. *JAMA*. 2003;289(19):2560-71.
2. Ford ES. Trends in mortality from all causes and cardiovascular disease among hypertensive and nonhypertensive adults in the United States. *Circulation* 2011;123: 1737-44
3. Blood Pressure Lowering Treatment Trialists' Collaboration. Effects of different blood-pressure-lowering regimens on major cardiovascular events: results of prospectively-designed overviews of randomised trials. *Lancet* 2003; 362:1527-35
4. Catalá-López F, Sanfélix-Gimeno G, García-Torres C., Ridao, S. Peiró M. Control of arterial hypertension in Spain: a systematic review and meta-analysis of 76 epidemiological studies on 341 632 participants. *J Hypertens* 2012;30:168-76

5. Labeit AM, Klotsche J, Pieper , Pittrow D, Einsle F, Stalla GK, et al. Changes in the prevalence, treatment and control of hypertension in Germany? A clinical-epidemiological study of 50,000 primary care patients. *PLoS One* 2012;7:e52229
6. Xi B, Liang Y, Reilly KH, Wang Q, Hu Y, Tang W. Trends in prevalence, awareness, treatment, and control of hypertension among Chinese adults 1991-2009. *Int J Cardiol* 2012;158:326-9
7. Harold EB. Tratamiento de los factores de riesgo cardiovascular en la atención del primer nivel. Instituto Cardiovascular Avanzado. Centro Médico Regional Audubon. Louisville EUA. *Mundo Médico* 1994; 247(XVII): 142-58.
8. Balaguer VI. Estrategias en el control de los factores de riesgo coronario en la prevención primaria y secundaria. Departamento de Cardiología. Hospital Santa Creu i Sant Pau. Barcelona. *Revista Española de Cardiología*. 1998; 1(suplemento): 30-5.
9. González C. Clínica de la hipertensión. México, Ediciones Médicas Actualizadas, 1997: 119-62.
10. Calvo VCG. La atención del paciente con hipertensión arterial. México, Biblioteca Médica Mexicana. ALFIL, 1999: 15-53.
11. Kathi C. Revisión sobre hipertensión. México, *Mundo Médico*. 2000; 316(XXVII): 65- 6.
12. Artigao R. Control de factores de riesgo en los programas de rehabilitación cardiaca. España, *Revista Española de Cardiología* 1995; 48(suplemento 1): 13-32.
13. Stripping A. Abriendo paso para un corazón sano. The barriers to a healthy heart. Estados Unidos, Grundy Lane. 1997: 1-15.
14. García Casilimas GA, Martín DA, Martínez MA, Merchán CR, Mayorga CA, Barragán AF. Fisiopatología de la hipertensión arterial secundaria a obesidad. *Archivos de Cardiología de Mexico* 2017; 87(4):336-44
15. De la Figuera von Wichmann M. Obesidad e hipertensión arterial. *Hipertensión y Riesgo Cardiovascular* 2000;17(9):414-6
16. Gutiérrez Hervás AI, Rizo Baeza MM, Martínez Amorós N, Cortés Castell E. Presión sistólica, obesidad abdominal y grasa corporal, predictores del síndrome metabólico en preescolares españoles. *Nutrición Hospitalaria* 2015;31(5), 2109-14.
17. Amato MC, Giordano C. Visceral adiposity index: an indicator of adipose tissue dysfunction. *Int J Endocrinol*. 2014;2014:730827.
18. Reyes-Barrera J, Sainz-Escárrega VH, Medina-Urritia AX, Jorge-Galarza E, Osorio-Alonso H, Torres-Tamayo M, et al. Dysfunctional Adiposity Index as a Useful Clinical Tool for Early Identification of Adipose Tissue Morpho-Functional Abnormalities and Cardiometabolic Disorders in Apparently Healthy Subjects. *Research Square* 2020. Available at: <https://www.researchsquare.com/article/rs-97962/v1>
19. Bertoli S, Leone A, Krakauer NY, Bedogni G, Vanzulli A, Redaelli VI, et al. Association of Body Shape Index (ABSI) with cardio-metabolic risk factors: A cross-sectional study of 6081 Caucasian adults. *PLoS One*. 2017 25;12(9):e0185013.
20. Doménech-Asensi G, Gómez-Gallego C, Ros-Berruazo G, García-Alonso FJ, Canteras-Jordana M. Critical overview of current anthropometric methods in comparison with a new index to make early detection of overweight in Spanish university students: the normalized weight-adjusted index. *Nutr Hosp*. 2018;35(2):359-67.
21. Andrade MD, Freitas MC, Sakumoto AM, Pappiani C, Andrade SC, Vieira VL, et al. Association of the conicity index with diabetes and hypertension in Brazilian women. *Arch Endocrinol Metab*. 2016;60(5):436-42.
22. Chang Y, Guo X, Chen Y, Guo L, Li Z, Yu S, et al. A body shape index and body roundness index: two new body indices to identify diabetes mellitus among rural populations in northeast China. *BMC Public Health*. 2015 19;15:794.
23. Salas-Salvadó J, Rubio MA, Barbany M, Moreno B and Grupo Colaborativo de la SEEDO. Consenso SEEDO 2007 para la evaluación del sobrepeso y la obesidad y el establecimiento de criterios de intervención terapéutica. *Med Clin (Barc)* 2007;128(5):184-96
24. Van Haute M, Rondilla E, Vitug JL, Batin KD, Abrugar RE, Quitoriano F, et al. Assessment of a proposed BMI formula in predicting body fat percentage among Filipino young adults. *Sci Rep*. 2020 Dec 15;10(1):21988.
25. Browning LM, Hsieh SD, Ashwell M. A systematic review of waist-to-height ratio as a screening tool for the prediction of cardiovascular disease and diabetes: 0.5 could be a suitable global boundary value. *Nutr Res Rev*. 2010;23(2):247-69.
26. Shirazu I , Sackey1 TH A, Tiburu EK , Mensah YB , Forson A. The use of Body Surface Index as a Better Clinical Health indicators compare to Body Mass Index and Body Surface Area for Clinical Application. *Int. J. S. Res. Sci. Engg. Technol*. 2018; 4(11): 131-6
27. Woolcott OO, Bergman RN. Relative fat mass (RFM) as anew estimator of whole-body fat percentage-A cross-sectional study in American adults individuals. *Sci Rep*. 2018;8(1):10980.
28. Gómez-Ambrosi J, Silva C, Catalán V, Rodríguez A, Galofré JC, Escalada J, et al. Clinical usefulness of a new equation for estimating body fat. *Diabetes Care*. 2012;35(2):383-8.
29. Molina-Luque R, Romero-Saldaña M, Álvarez-Fernández C, Bannasar-Veny M, Álvarez-López Á, Molina-Recio G. Equation Córdoba: A Simplified Method for Estimation of Body Fat (ECORE-BF). *Int J Environ Res Public Health*. 2019;16(22):4529.
30. Mill-Ferreya E, Cameno-Carillo V, Saúl-Gordo H, Camí-Lavado MC. Estimation of the percentage of body fat based on the body mass index and the abdominal circumference: Palafolls Formula. *Semergen*. 2019;45(2):101-8.
31. Deurenberg P, Wetstrate JA, Seidell JC. Body mass index as a measure of body fatness: age- and sex- specific prediction formulas. *Br J Nutr* 1991; 65: 105-14.
32. Seventh Report of the Joint National Committee on Prevention, Detection, Evaluation, and Treatment of High Blood Pressure (JNC 7 Express). Available at: https://www.paho.org/hq/dmdocuments/2010/JNC7_interactivo.pdf

Executive Functions Profiles in Preschool Children with Autism Spectrum Disorder

Perfiles de funciones ejecutivas en niños preescolares con trastorno del espectro autista

Arnela Pasalic , **Haris Memisevic** 

University of Sarajevo, Faculty of Educational Sciences, Sarajevo, BiH

Corresponding author

Haris Memisevic
E-mail: hmemisevic@gmail.com

Received: 20 - XII - 2022

Accepted: 15 - I - 2023

doi: 10.3306/AJHS.2023.38.03.52

Abstract

Objective: Executive functions (EFs) play a crucial role in overall human functioning. Children with Autism Spectrum Disorder (ASD) often have EFs deficits. The aim of this study was to examine EFs in preschool children with ASD.

Methods: The sample for this study comprised 32 children (27 boys, mean age 65.3 months, SD- 4.0 months) with ASD. The control group consisted of 32 children with neurotypical development (16 boys, mean age 64.3 months, SD- 5.1 months). EFs were assessed with *Behavior Rating Inventory of Executive Function- Preschool version*.

Results: The results of this study indicated that children with ASD have more heterogeneous EFs profiles than children with typical development. Children with ASD had substantially lower EFs than children with neurotypical development.

Conclusion: Identifying EFs deficits in children with ASD at an early age may help create programs to ameliorate these deficits. Psychologists and educators have many evidence-based interventions at their disposal to improve EFs in children with ASD.

Key words: Executive functions, Developmental domains, Autism Spectrum Disorder, Preschool children.

Resumen

Objetivo: Las funciones ejecutivas (FE) desempeñan un papel crucial en el funcionamiento humano general. Los niños con Trastorno del Espectro Autista (TEA) a menudo presentan déficits de FE. El objetivo de este estudio fue examinar las FE en niños preescolares con TEA.

Métodos: La muestra de este estudio estaba formada por 32 niños (27 varones, con una edad media de 65,3 meses, SD- 4,0 meses) con TEA. El grupo de control estaba formado por 32 niños con desarrollo neurotípico (16 niños, edad media de 64,3 meses, SD- 5,1 meses). Las FE se evaluaron con el Inventario de Calificación de la Conducta de la Función Ejecutiva - versión preescolar.

Resultados: Los resultados de este estudio indicaron que los niños con TEA tienen perfiles de FE más heterogéneos que los niños con desarrollo típico. Los niños con TEA tenían unas FE sustancialmente más bajas que los niños con desarrollo neurotípico.

Conclusión: Identificar los déficits de EFs en niños con TEA a una edad temprana puede ayudar a crear programas para mejorar estos déficits. Los psicólogos y educadores tienen muchas intervenciones basadas en la evidencia a su disposición para mejorar las FE en los niños con TEA.

Palabras clave: Funciones ejecutivas, Dominios del desarrollo, Trastorno del espectro autista, Niños en edad preescolar.

Introduction

Executive functions (EFs) refer to a set of higher-order cognitive processes involved in goal-directed behavior¹. They are crucial for everyday functioning and are described as a “cognitive toolkit of success”². Defining EFs is a difficult task given the different theoretical standpoints of the researchers and different taxonomies³. One of the definitions is that EFs are self-regulatory behaviors necessary for selecting and sustaining actions and guiding behaviors in the context of rules⁴. EFs are required for novel tasks and situations, problem solving, conscious choices, and overriding a strong internal or external pull⁵.

EFs develop rapidly in early childhood and evidence clearly shows their importance for school readiness and academic success⁶. The development of EFs during childhood is of great importance for many later life outcomes, such as health and wealth⁷. However, despite being widely researched, there are still many questions related to EFs. One of the questions is related to the dimensionality of EFs, that is are EFs unidimensional or multidimensional construct, especially at a younger age⁸. Recent research suggests that EFs are multifaceted and that different EFs are correlated but separable⁹. Most researchers agree that EFs consist of a wide range of skills, including inhibition, mental flexibility, self-control, shifting of attention, initiation, impulsivity, working memory, and planning¹⁰⁻¹². It is also important to note that some researchers view EFs as a unitary concept at preschool age¹³ and that differentiation into separate skills begins at school age. Some authors have proposed that at preschool age it is possible to differentiate two EFs, namely working memory and inhibition, while the shifting, as the third EF, appears later, around 8 years of age¹⁴.

Autism Spectrum Disorder (ASD) is a neurodevelopmental disorder characterized by deficits in the social-communication domain and a pattern of repetitive sensory-motor behaviors^{15,16}. As the name implies, ASD is a highly heterogeneous disorder with symptoms ranging from mild to severe¹⁷. According to the 5th Edition of Diagnostic and Statistical Manual of Mental Disorders, ASD is categorized into three severity levels: Level 1 “Requiring support”, Level 2 “Requiring substantial support” and Level 3 “Requiring very substantial support”¹⁶. ASD is a common neurodevelopmental disorder with a current prevalence rate of 2.79% in children aged 3 to 17 years¹⁸. Given the high prevalence rate, it is particularly important to identify ASD at an early age which, in turn, will lead to provisions of timely interventions and possibly improve the developmental trajectory of the disorder.

EFs have been widely studied in neurodiverse populations, including traumatic brain injury¹⁹, schizophrenia²⁰, and depression²¹. In addition to this, EFs deficits were widely examined in developmental disorders, including Attention

Deficit Hyperactivity Disorder, Autism Spectrum Disorder, and Intellectual Disability²²⁻²⁴. Much scientific attention has been directed to EFs development in individuals with ASD. It is widely recognized that children with ASD have deficits in EFs, which, consequentially, affect their adjustment and social skills²⁵. Children with better EFs have more prosocial behavior according to their peer’s rating²⁶. EFs play a significant role in the adaptive behavior of children with ASD, thus affecting their overall outcomes²⁷. More specifically, the research has shown that EFs affect three domains of adaptive behavior: socialization, communication and daily living²⁸. Given the role EFs play in everyday functioning, a rationale for the increasing research in this area stems from the notion that EFs may improve everyday functioning. Many studies have found a relationship between social communication deficits and EFs in children with ASD^{29,30}. However, the exact nature of this relationship is not clear. More specifically, it is unclear whether EFs deficits contribute to social and communication deficits or vice versa. Although there is strong evidence of EFs deficits present in individuals with ASD, findings for the preschool age have been inconsistent³¹ and require further scientific investigation. Thus, given the wide implications of EFs deficits in ASD, we wanted to further examine the EFs profiles in this group of children. We also wanted to examine how EFs in children with ASD compare with the profiles of typical, age-matched, preschool children. The research questions we set to answer in this study are:

1. Do children with ASD have more heterogeneous scores across EFs domains than typically developing children?
2. Are there differences in EFs of children with ASD and typically developing children?
3. Is ASD severity level related to EFs?

Methods

Participants

The sample for this study consisted of 32 children with ASD (27 boys, mean age 65.3 months, SD- 4.0 months). Children with ASD were conveniently recruited from the Center for Early Intervention in Sarajevo that provides services to families and children with ASD. Children were referred to the Center after a formal diagnosis of ASD was made by a neuropsychiatrist at the local clinic. The inclusion criterion was that children had a formal diagnosis of ASD and were younger than 7 years. The control group consisted of 32 typically developing children (16 boys, mean age 64.3 months, SD- 5.1 months) who, according to their parent’s statements, did not have developmental disability. Children with typical development were conveniently recruited from two local kindergartens. The inclusion criterion was that children did not have a diagnosis of developmental disability and were younger than 7 years. The mean age of children

in the ASD group was not different from the mean age in the control group ($t(62)=0.93$; $p=.36$). However, the groups were not matched in relation to gender ($\chi^2 = 8.4$; $p < .01$), as there were significantly more boys than girls in ASD group, a ratio which corresponds to the actual population rates of ASD in relation to gender³².

Procedure

Parents of children with ASD who attended the Center for Early Intervention were asked to participate in the study. Parents provided basic demographic information for their children and granted permission to early special educators to complete the Behavior Rating Inventory of Executive Functions- Preschool Edition (BRIEF-P; Gioia et al., 2003), and the Gilliam Autism Rating Scale (GARS; Gilliam, 2014) for this research. Total of 32 written consent forms were obtained and professionals (early childhood special educators) who have a wide experience working with children with ASD (ranging from 8-20 years) and have worked with these children for at least two months completed the scales. Parents of typically developing children attending two local kindergartens were asked to participate in the study. After the written parental consent forms were received, early childhood educators completed BRIEF-P for 32 children with neurotypical development. The approval for this study was granted by the Faculty of Educational Sciences, University of Sarajevo.

Instruments

The *Behavior Rating Inventory of Executive Function – Preschool Version* (BRIEF-P;³³) is an ecologically valid measure of executive functions intended for children aged 2-5.11 years. BRIEF-P consists of five clinical scales: Inhibit, Shift, Emotional Control, Working Memory, and Plan/Organize. These five clinical scales yield three indexes: Inhibitory Self-Control Index, Flexibility index, and Emergent Metacognition Index. The overall composite index is the Global Executive Index. For this study, we only used the clinical scales of the BRIEF-P, which are continuous variables. According to the BRIEF manual Cronbach’s alphas for the BRIEF-P clinical scales ranges from $r = .80$ to $.90$ for parent version and from $.90$ to $.97$ for the teacher version.

The BRIEF-P takes 10-15 minutes to complete. Raw scores were used in the analysis and lower score means better executive function. We used Bosnian translation of the BRIEF-P³⁴.

The *Gilliam Autism Rating Scale - Third Edition* (GARS-3;³⁵) was developed to screen for ASD in individuals aged between 3 and 22 years. The GARS-3 consists of six clinical subscales: Restrictive/Repetitive Behaviors, Social Interaction, Social Communication, Emotional Responses, Cognitive Style, and Maladaptive Speech. These six clinical subscales are converted to Autism Index Composite score, a measure that was used in

this study and indicates the severity of autism. Interclass correlation coefficients of the subscales are within the acceptable range ($r=.71 - .85$). Internal consistency, Cronbach’s alpha is high and is above $.90$.

Statistical analysis

For the first research question, we we calculated Pearson’s correlation coefficients between EFs (as measured by the BRIEF-P) for children with ASD and children with neurotypical development. These correlations helped us determine whether the EFs profiles of children with ASD are uneven. We next separately standardized the scores of BRIEF-P for each group of children and presented their distribution to examine whether children with ASD have more heterogeneous score distribution within the EFs domains than children with neurotypical development. For the second research question, we performed independent t-tests and presented Cohen’s d effect size of mean differences in EFs between children with ASD and children with neurotypical development. For the third research question, we calculated the Pearson correlation coefficients between autism severity (as measured by the GARS) and EFs. We also regressed scores of EFs clinical scales to predict ASD severity. An alpha level of $.05$ was used as a benchmark for statistical significance. The statistical analysis was performed with the computer program SPSS v.27³⁶.

Results

Heterogeneity of EFs profiles

The first research question was to examine the heterogeneity in EFs domains in children with ASD and children with neurotypical development. We first present correlations between EFs domains in **table 1**.

Table 1: Correlations between EFs domains in children with ASD and children with neurotypical development.

Executive functions	Variables	1	2	3	4	5
	Inhibit	---	.38	.76	.46	.29
	Shift	.58	---	.66	.48	.38
	Emotional Control	.67	.70	---	.34	.12
	Working memory	.36	.13	.10	---	.78
	Planning	.78	.48	.40	.59	---

Note. Correlations below diagonal line are for children with ASD, and above the line are for neurotypically developing children. Correlations in bold font are statistically significant at $p<.05$ level.

As for the correlations within the domain of EF for children with ASD, only two of the correlations were not statistically significant, the one between working memory and shifting, and the one between *working memory* and *emotional control*. In typically developing children, three correlations within the domain of EF were not statistically significant, the correlation between *emotional control* and *working memory*, the correlation between *emotional control* and *planning*, and the correlation between

inhibition and planning. We next inspected standardized values within EFs domains in children with ASD and children with neurotypical development to examine the spread of results. We first converted EFs scores into standardized z-scores values separately for children with ASD and separately for children with neurotypical development. In **figure 1**, we presented the interquartile range of these scores.

Figure 1: Interquartile range of standardized values of EF domains in children with ASD and typically developing children.

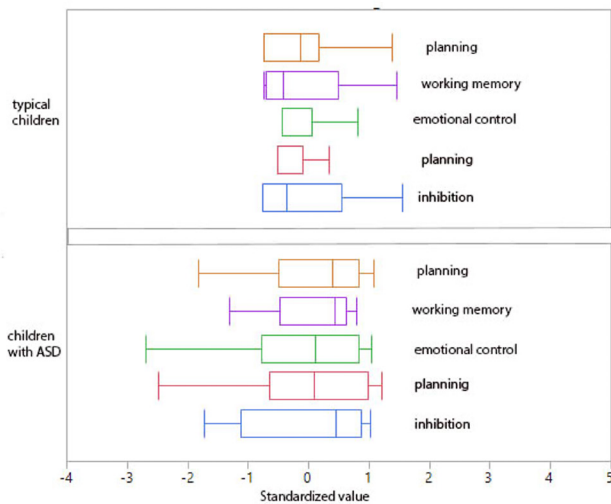

As can be seen from **figure 1**, EFs profiles seem to be more heterogeneous in children with ASD, especially in the domains of emotional control and planning.

Differences in EFs between children with ASD and children with typical development

The second research question was to examine the differences in the mean scores in EFs between children with ASD and children with neurotypical development. These results are shown in **table II**.

Table II: Group differences for EF domains and Developmental domains between children with ASD and typically developing children.

EF domains	Variable	Children with ASD		Typical children		t (62)*	Cohen' d
		M	SD	M	SD		
EF domains	Inhibit	41.7	6.2	19.9	5.2	15.3	3.8
	Shift	23.4	5.4	11.2	2.4	11.7	2.9
	Emotional Control	25.0	4.8	11.8	4.0	11.9	3.0
	Working memory	46.5	5.7	21.4	5.9	17.3	4.3
	Planning	26.2	4.5	12.4	3.3	14.0	3.5

Note.* all p's are <.001.

There were statistically significant and large differences in favor of children with neurotypical development on all EFs domains mean scores. All effect sizes were large according to criteria set by Cohen³⁷. The largest differences in EFs were for the variables working memory and inhibition.

The relation between ASD severity and EFs

The last research question examined the correlation of the autism severity level as measured by the Gilliam Autism Rating Scale and EFs domains. These results are shown in **table III**.

Table III: The Pearson correlation of the Gilliam Autism Rating Scale and EF domains and Developmental domains.

Variable	Gilliam Autism Rating Scale	
	r	p
EF domains		
Inhibit	.31	.10
Shift	.35	.04
Emotional Control	.29	.10
Working memory	.33	.06
Planning	.42	.01

Note. N=32. Values in bold are statistically significant at p < .05 level.

The severity of autism symptoms as measured by GARS-3 is significantly related to EFs domains of Shifting and Planning. The correlation between autism severity and working memory narrowly fell short of reaching statistical significance (p=.06). All other correlations were not statistically significant. On the other hand, results of the regression analysis of EFs domain predicting severity of ASD were not statistically significant (F = 1.7, p = .17) and are shown in **table IV**.

Table IV: Regression analysis of EFs domains predicting ASD severity.

EFs	Estimate	Std Beta	Std Error	t Ratio	p
Inhibition	-0.56	-0.26	0.75	-0.74	0.46
Shifting	0.43	0.18	0.61	0.70	0.49
Emotional control	0.48	0.18	0.77	0.62	0.54
Working memory	0.38	0.16	0.50	0.75	0.46
Planning	1.10	0.38	1.00	1.10	0.28

Note. N=32, R² = .24; R²_(adjusted) = .09.

Discussion

The goal of the present study was to investigate EFs in preschool children with ASD. The first finding of this study was that preschool children with ASD had slightly more heterogeneous EFs profiles than children with neurotypical development. We mentioned earlier some reports that children with ASD have unbalanced EFs profiles, as indicated by strengths and weaknesses in various domains. This study showed that children with ASD had more variable EFs scores than children with neurotypical development on all EFs clinical subscales. Although children with ASD had significant EFs deficits on the group level, given the high variability in their scores, it is evident that some individuals with ASD had smaller or even non-existing EFs differences compared to children with neurotypical development. This again points to the importance of examining differences on the individual level and the group level.

Conversely, correlations of all EFs domain were slightly stronger in children with ASD. These findings

contrasted with our expectations, as we hypothesized lower correlations between various EFs domains in children with ASD given the genetic and phenotypical heterogeneity of ASD³⁸. However, it might be the case that EFs profiles in children with ASD become more uneven at a later chronological age. This explanation is related to the developmental trajectory of EFs. It might be the case that EFs, after starting as a unitary concept¹³, remain more unitary/less specialized in children with ASD and differentiate more slowly in this group of children. This might explain the stronger relationships within EFs domains in preschool children with ASD. Similarly, it has been shown, that EF differentiation in children with intellectual disability begins at a preschool age⁸. Lastly, another explanation for these findings might be due to the assessment instruments that we used. Although ecologically valid, the BRIEF-P was not developed specifically for children with ASD and thus might not have the same measurement properties as in the group of children with neurotypical development. Understanding the individual differences of children with ASD might help practitioners design better treatment protocols³⁹.

We found large, statistically significant differences between children with ASD and children with neurotypical development in all EFs domains. The most significant differences were for the domain of working memory, followed by inhibition, planning, emotional control, and shifting. However, existing research does not point to the universal profile of weaknesses in EFs that we found in our study. For example, other studies have also found significant EFs differences in preschools with ASD and preschoolers with neurotypical development in the domain of shifting and inhibition but not on visual-spatial working memory tasks⁴⁰. In a study that used the BRIEF-P for the assessment of EFs, significant differences between preschoolers with ASD and children with neurotypical development were found on the subscales: inhibition and shifting but not on the subscale working memory⁴¹. On the other hand, there are studies that point to working memory as the main EFs impairment in children with ASD⁴². A large meta-analysis of 28 studies involving 819 individuals with ASD has found significant impairments in working memory in this group compared to typically developing individuals⁴³. The possible reason individuals with ASD have impairments in working memory might be that they are deficient in the use of verbal mediation strategies that helps to maintain goal-related information in the working memory⁴⁴. As for the differences in the studies regarding the role of working memory deficit in ASD, the potential explanation for these differences might be related to factors such as autism phenotype, intelligence, and autism severity level which differ in participants across studies. The most likely explanation is that working memory is intact in some children with ASD, while in other children with ASD, working memory is much more impaired.

Autism severity was statistically significantly correlated with two executive functions: shifting and planning. The results in our study are in line with earlier studies that found people with autism to have particular deficits in shifting and planning⁴⁵. We have now found these significant deficits to be present in preschool children with ASD as well. We also performed a regression analysis to determine the ASD severity based on EFs measures. The results indicated a non-significant model, which means the EFs domains were not significant predictors of ASD severity. However, this result should be interpreted cautiously as the sample size was rather small for regression models. Future studies should aim to validate or refute these findings with a larger, more diverse sample of preschool children with ASD.

Identification of EFs deficits in children at an early age will help create programs to ameliorate these deficits. Earlier research has shown that it is possible to improve EFs in preschool children⁴⁶. This is especially relevant for children with ASD. Some reports showed that Early Intensive Behavioral Training could significantly improve EFs in children with ASD³⁸. Behavioral intervention, through the use of positive reinforcement, has the potential to significantly improve working memory in children with ASD⁴². Programs that aim flexibility, goal-setting, and planning significantly improve EFs in children with ASD and improve social skills⁴⁷. Besides these programs, it is also noteworthy to mention physical activities as an efficient way to improve EFs in children with ASD. Many studies have shown positive effects of martial arts⁴⁸ and exergaming⁴⁹ on EFs. In addition, physical activity has also been found to positively affect the academic achievements of children with ASD⁵⁰. Educators have many evidence-based interventions at their disposal to improve EFs in children with ASD. Better understanding of EFs deficits in ASD and individual EFs will lead to better intervention programs at an early age.

The strength of this study is the employment of ecologically valid measure, the BRIEF-P, in the assessment of EFs in a group of preschool children with ASD. In addition, we also assessed the control group of children with neurotypical development, which in turn helped us identify which EFs are particularly vulnerable in children with ASD.

There are several limitations of this study that need to be noted. First of all, we used only one measure of EFs domains (BRIEF-P). It would be useful if we have used parental's reports as well, which would increase the reliability of the results. Second, it would also be useful if we have used some performance-based measures of EFs. Third, the sample size was relatively small, thus reducing the generalizability of the results. Conversely, the mean differences in EFs were exceptionally large, so there was a minimal risk of committing a type I error. Lastly, we did not have IQ scores of children, a measure which could be used as an important covariate in this study.

Conclusions

Children with Autism Spectrum Disorder had more heterogeneous EFs profiles than typically developing children. There is more interindividual variability in EFs a domain scores in children with ASD than in typically developing children. Preschool children with ASD had significantly lower EFs domains scores than children with typical development. Autism severity level had a

significant effect on shifting and planning domains of EFs. However, EFs domain scores were not good predictors of ASD severity.

Conflict of interest

None

References

1. Tungate AS, Conners FA. Executive function in Down syndrome: A meta-analysis. *Research in Developmental Disabilities* 2021;108:103802. doi: <https://doi.org/10.1016/j.ridd.2020.103802>
2. Hendry A, Jones EJH, Charman T. Executive function in the first three years of life: Precursors, predictors and patterns. *Developmental Review* 2016;42:1-33. doi: <https://doi.org/10.1016/j.dr.2016.06.005>
3. Jurado MB, Rosselli M. The Elusive Nature of Executive Functions: A Review of our Current Understanding. *Neuropsychology Review* 2007;17(3):213-33. doi: [10.1007/s11065-007-9040-z](https://doi.org/10.1007/s11065-007-9040-z)
4. Mahone EM, Cirino PT, Cutting LE, Cerrone PM, Hagelthorn KM, Hiemenz JR, et al. Validity of the behavior rating inventory of executive function in children with ADHD and/or Tourette syndrome*. *Archives of Clinical Neuropsychology* 2002;17(7):643-62. doi: [10.1093/arclin/17.7.643](https://doi.org/10.1093/arclin/17.7.643)
5. Diamond A. The Early Development of Executive Functions. Lifespan cognition: Mechanisms of change. New York, NY, US: Oxford University Press 2006:70-95.
6. Blair C. Executive function and early childhood education. *Current Opinion in Behavioral Sciences* 2016;10:102-07. doi: <https://doi.org/10.1016/j.cobeha.2016.05.009>
7. Thompson A, Steinbeis N. Sensitive periods in executive function development. *Current Opinion in Behavioral Sciences* 2020;36:98-105. doi: <https://doi.org/10.1016/j.cobeha.2020.08.001>
8. Memisevic H, Malec D, Pasalic A. Factor structure of the BRIEF-P teacher version in a sample of Bosnian preschool children with intellectual disability. *Child Neuropsychology* 2021;1-12. doi: [10.1080/09297049.2021.2008338](https://doi.org/10.1080/09297049.2021.2008338)
9. Friedman NP, Miyake A, Young SE, DeFries JC, Corley RP, Hewitt JK. Individual differences in executive functions are almost entirely genetic in origin. *Journal of Experimental Psychology: General* 2008;137(2):201-25. doi: [10.1037/0096-3445.137.2.201](https://doi.org/10.1037/0096-3445.137.2.201)
10. McLean RL, Johnson Harrison A, Zimak E, Joseph RM, Morrow EM. Executive Function in Proband With Autism With Average IQ and Their Unaffected First-Degree Relatives. *Journal of the American Academy of Child & Adolescent Psychiatry* 2014;53(9):1001-09. doi: <https://doi.org/10.1016/j.jaac.2014.05.019>
11. Garon N, Bryson SE, Smith IM. Executive function in preschoolers: A review using an integrative framework. *Psychological Bulletin* 2008;134(1):31-60. doi: [10.1037/0033-2909.134.1.31](https://doi.org/10.1037/0033-2909.134.1.31)
12. Gioia GA, Isquith PK, Kenworthy L, Barton RM. Profiles of Everyday Executive Function in Acquired and Developmental Disorders. *Child Neuropsychology* 2002;8(2):121-37. doi: [10.1076/chin.8.2.121.8727](https://doi.org/10.1076/chin.8.2.121.8727)
13. Wiebe SA, Sheffield T, Nelson JM, Clark CAC, Chevalier N, Espy KA. The structure of executive function in 3-year-olds. *Journal of Experimental Child Psychology* 2011;108(3):436-52. doi: <https://doi.org/10.1016/j.jecp.2010.08.008>
14. Lee K, Bull R, Ho RMH. Developmental Changes in Executive Functioning. *Child Development* 2013;84(6):1933-53. doi: <https://doi.org/10.1111/cdev.12096>
15. Lord C, Elsabbagh M, Baird G, Veenstra-Vanderweele J. Autism spectrum disorder. *The Lancet* 2018;392(10146):508-20. doi: [https://doi.org/10.1016/S0140-6736\(18\)31129-2](https://doi.org/10.1016/S0140-6736(18)31129-2)
16. American Psychiatric Association. Diagnostic and Statistical Manual of Mental Disorders. 5th ed. Washington, DC: APA, Washington, DC 2013.
17. Kantzer A-K, Femell E, Gillberg C, Miniscalco C. Autism in community pre-schoolers: Developmental profiles. *Research in Developmental Disabilities* 2013;34(9):2900-08. doi: <https://doi.org/10.1016/j.ridd.2013.06.016>
18. Xu G, Strathearn L, Liu B, O'Brien M, Kopelman TG, Zhu J. Prevalence and Treatment Patterns of Autism Spectrum Disorder in the United States, 2016. *JAMA Pediatrics* 2019;173(2):153-59. doi: [10.1001/jamapediatrics.2018.4208](https://doi.org/10.1001/jamapediatrics.2018.4208)
19. Slomine BS, Gerring JP, Grados MA, Vasa R, Brady KD, Christensen JR, et al. Performance on measures of 'executive function' following pediatric traumatic brain injury. *Brain Injury* 2002;16(9):759-72. doi: [10.1080/02699050210127286](https://doi.org/10.1080/02699050210127286)
20. Kluge-Schiavon B, Sanvicente-Vieira B, Kristensen CH, Grassi-Oliveira R. Executive functions rehabilitation for schizophrenia: A critical systematic review. *Journal of Psychiatric Research* 2013;47(1):91-104. doi: <https://doi.org/10.1016/j.jpsyres.2012.10.001>
21. Han G, Helm J, Lucha C, Zahn-Waxler C, Hastings PD, Klimes-Dougan B. Are Executive Functioning Deficits Concurrently and Predictively Associated with Depressive and Anxiety Symptoms in Adolescents? *Journal of Clinical Child & Adolescent Psychology* 2016;45(1):44-58. doi: [10.1080/15374416.2015.1041592](https://doi.org/10.1080/15374416.2015.1041592)
22. Barkley RA, Murphy KR. The Nature of Executive Function (EF) Deficits in Daily Life Activities in Adults with ADHD and Their Relationship to Performance on EF Tests. *Journal of Psychopathology and Behavioral Assessment* 2011;33(2):137-58. doi: [10.1007/s10862-011-9217-x](https://doi.org/10.1007/s10862-011-9217-x)

23. Happé F, Booth R, Charlton R, Hughes C. Executive function deficits in autism spectrum disorders and attention-deficit/hyperactivity disorder: Examining profiles across domains and ages. *Brain and Cognition* 2006;61(1):25-39. doi: <https://doi.org/10.1016/j.bandc.2006.03.004>
24. Memisevic H, Sinanovic O. Executive function in children with intellectual disability – the effects of sex, level and aetiology of intellectual disability. *Journal of Intellectual Disability Research* 2014;58(9):830-37. doi: <https://doi.org/10.1111/jir.12098>
25. Reed T. Visual Perspective Taking as a Measure of Working Memory in Participants With Autism. *Journal of Developmental and Physical Disabilities* 2002;14(1):63-76. doi: [10.1023/A:1013515829985](https://doi.org/10.1023/A:1013515829985)
26. Zorza JP, Marino J, Acosta Mesas A. Executive Functions as Predictors of School Performance and Social Relationships: Primary and Secondary School Students. *The Spanish Journal of Psychology* 2016;19:E23. doi: [10.1017/sjp.2016.23](https://doi.org/10.1017/sjp.2016.23) [published Online First: 2016/05/12]
27. Pugliese CE, Anthony L, Strang JF, Dudley K, Wallace GL, Kenworthy L. Increasing Adaptive Behavior Skill Deficits From Childhood to Adolescence in Autism Spectrum Disorder: Role of Executive Function. *Journal of Autism and Developmental Disorders* 2015;45(6):1579-87. doi: [10.1007/s10803-014-2309-1](https://doi.org/10.1007/s10803-014-2309-1)
28. Kenny L, Cribb SJ, Pellicano E. Childhood Executive Function Predicts Later Autistic Features and Adaptive Behavior in Young Autistic People: a 12-Year Prospective Study. *Journal of Abnormal Child Psychology* 2019;47(6):1089-99. doi: [10.1007/s10802-018-0493-8](https://doi.org/10.1007/s10802-018-0493-8)
29. McEvoy RE, Rogers SJ, Pennington BF. Executive Function and Social Communication Deficits in Young Autistic Children. *Journal of Child Psychology and Psychiatry* 1993;34(4):563-78. doi: <https://doi.org/10.1111/j.1469-7610.1993.tb01036.x>
30. Pellicano E. The Development of Executive Function in Autism. *Autism Research and Treatment* 2012;2012:146132. doi: [10.1155/2012/146132](https://doi.org/10.1155/2012/146132)
31. Garon N, Smith IM, Bryson SE. Early executive dysfunction in ASD: Simple versus complex skills. *Autism Research* 2018;11(2):318-30. doi: <https://doi.org/10.1002/aur.1893>
32. Nicholas JS, Charles JM, Carpenter LA, King LB, Jenner W, Spratt EG. Prevalence and Characteristics of Children With Autism-Spectrum Disorders. *Annals of Epidemiology* 2008;18(2):130-36. doi: <https://doi.org/10.1016/j.annepidem.2007.10.013>
33. Gioia GA, Espy KA, Isquith PK. Behavior Rating Inventory of Executive Function - Preschool Version. Odessa, FL: Psychological Assessment Resources: Odessa, FL: Psychological Assessment Resources 2003.
34. Dzambo I, Sporisovic L, Memisevic H. Executive Functions in Preschool Children Born Preterm in Canton Sarajevo, Bosnia and Herzegovina. *International Journal of Pediatrics* 2018;6(4):7443-50. doi: [10.22038/ijp.2018.29481.2584](https://doi.org/10.22038/ijp.2018.29481.2584)
35. Gilliam JE. Gilliam Autism Rating Scale. Austin, TX: PRO-ED: Austin, TX: PRO-ED 2014.
36. IBM SPSS Statistics for Windows, Version 27.0 [program]. Armonk, NY: Armonk, NY: IBM corp, 2020.
37. Cohen J. Statistical power analysis for the behavioral sciences: New York: Academic press 2013.
38. Skogli EW, Andersen PN, Isaksen J. An Exploratory Study of Executive Function Development in Children with Autism, after Receiving Early Intensive Behavioral Training. *Developmental Neurorehabilitation* 2020;23(7):439-47. doi: [10.1080/17518423.2020.1756499](https://doi.org/10.1080/17518423.2020.1756499)
39. Geurts H, Sinzig J, Booth R, Happe F. Neuropsychological heterogeneity in executive functioning in autism spectrum disorders. *International Journal of Developmental Disabilities* 2014;60(3):155-62. doi: [10.1179/2047387714Y.0000000047](https://doi.org/10.1179/2047387714Y.0000000047)
40. Valeri G, Casula L, Napoli E, Stievano P, Trimarco B, Vicari S, et al. Executive Functions and Symptom Severity in an Italian Sample of Intellectually Able Preschoolers with Autism Spectrum Disorder. *Journal of Autism and Developmental Disorders* 2020;50(9):3207-15. doi: [10.1007/s10803-019-04102-0](https://doi.org/10.1007/s10803-019-04102-0)
41. Carotenuto M, Ruberto M, Fontana ML, Catania A, Misuraca E, Precezanano F, et al. Executive functioning in autism spectrum disorders: A case-control study in preschool children. *Current Pediatric Research* 2019;23:112-6.
42. Baltruschat L, Hasselhorn M, Tarbox J, Dixon DR, Najdowski AC, Mullins RD, et al. Addressing working memory in children with autism through behavioral intervention. *Research in Autism Spectrum Disorders* 2011;5(1):267-76. doi: <https://doi.org/10.1016/j.rasd.2010.04.008>
43. Wang Y, Zhang Y-b, Liu L-l, Cui J-f, Wang J, Shum DHK, et al. A Meta-Analysis of Working Memory Impairments in Autism Spectrum Disorders. *Neuropsychology Review* 2017;27(1):46-61. doi: [10.1007/s11065-016-9336-y](https://doi.org/10.1007/s11065-016-9336-y)
44. Joseph RM, Steele SD, Meyer E, Tager-Flusberg H. Self-ordered pointing in children with autism: failure to use verbal mediation in the service of working memory? *Neuropsychologia* 2005;43(10):1400-11. doi: <https://doi.org/10.1016/j.neuropsychologia.2005.01.010>
45. Blijd-Hoogewys EMA, Bezemer ML, van Geert PLC. Executive Functioning in Children with ASD: An Analysis of the BRIEF. *Journal of Autism and Developmental Disorders* 2014;44(12):3089-100. doi: [10.1007/s10803-014-2176-9](https://doi.org/10.1007/s10803-014-2176-9)
46. Volckaert AMS, Noël M-P. Training executive function in preschoolers reduce externalizing behaviors. *Trends in Neuroscience and Education* 2015;4(1):37-47. doi: <https://doi.org/10.1016/j.tine.2015.02.001>
47. Kenworthy L, Anthony LG, Naiman DQ, Cannon L, Wills MC, Luong-Tran C, et al. Randomized controlled effectiveness trial of executive function intervention for children on the autism spectrum. *Journal of Child Psychology and Psychiatry* 2014;55(4):374-83. doi: <https://doi.org/10.1111/jcpp.12161>
48. Phung JN, Goldberg WA. Promoting Executive Functioning in Children with Autism Spectrum Disorder Through Mixed Martial Arts Training. *Journal of Autism and Developmental Disorders* 2019;49(9):3669-84. doi: [10.1007/s10803-019-04072-3](https://doi.org/10.1007/s10803-019-04072-3)
49. Hilton CL, Cumpata K, Klohr C, Gaetke S, Artner A, Johnson H, et al. Effects of Exergaming on Executive Function and Motor Skills in Children With Autism Spectrum Disorder: A Pilot Study. *American Journal of Occupational Therapy* 2014;68(1):57-65. doi: [10.5014/ajot.2014.008664](https://doi.org/10.5014/ajot.2014.008664)
50. Nakutin SN, Gutierrez G. Effect of Physical Activity on Academic Engagement and Executive Functioning in Children With ASD. *School Psychology Review* 2019;48(2):177-84. doi: [10.17105/SPR-2017-0124.V48-2](https://doi.org/10.17105/SPR-2017-0124.V48-2)

ORIGINAL

Gender-based evaluation of haematological and some inflammation markers in patients with mandibular fracture in a tertiary Hospital in southeast, Nigeria

Evaluación basada en el género de los marcadores hematológicos y de inflamación en pacientes con fractura mandibular en un Hospital terciario del sureste de Nigeria

Emmanuel Ifeanyi Obeagu¹ , Pilar Tomás-Gil² , Josep Lluís Coll Villalonga² , Pau Martí-Lliteras³ , Getrude Uzoma Obeagu^{3,4} 

1. Department of Medical Laboratory Science, Kampala International University, Western Campus, Ishaka, Uganda.

2. ADEMA-Health Group. IUNICS. University of Balearic Islands. Spain

3. Department of Nursing Services, National Orthopaedic Hospital, Enugu, Enugu State, Nigeria.

4. Department of Nursing Science, Ebonyi State University, Abakaliki, Ebonyi State, Nigeria.

Corresponding author

Emmanuel Ifeanyi Obeagu

E-mail: emmanuelobeagu@yahoo.com

Received: 23 - XII - 2022

Accepted: 20 - I - 2023

doi: 10.3306/AJHS.2023.38.03.59

Abstract

Aim: The study was done to evaluate hematological parameters and some inflammatory markers in patients with mandibular fractures in a tertiary hospital in Southeast, Nigeria.

Methods: A total of 100 subjects were selected for the study comprising of 50 patients with mandibular fracture and 50 apparently healthy individuals attended National Orthopedic Hospital, Enugu, Nigeria. About 3ml of venous blood was collected from antecubital fossa following aseptic techniques into EDTA containers for FBC determinations. The full blood counts of the subjects were determined using Mindray BC-3000 Plus. The data were analyzed using student t-test and present as mean \pm standard deviation using SPSS version 20 and level of significance set at $P < 0.05$.

Results: The study showed increase in the red lines such as the red cells, hemoglobin and Packed Cell Volume of the male compared to the females.

Conclusions: The society are advised to minimize some activities that will predispose them to mandibular fractures as there are limited surgeons with expertise in this part of the world to resolve the issues fast and with utmost well-being of the patients.

Key words: Gender, haematological parameters, inflammation, mandibular fractures.

Resumen

Objetivo: El estudio se realizó para evaluar los parámetros hematológicos y algunos marcadores inflamatorios en pacientes con fracturas mandibulares en un hospital terciario del sureste de Nigeria.

Material y métodos: Se seleccionó un total de 100 sujetos para el estudio, compuesto por 50 pacientes con fractura mandibular y 50 individuos aparentemente sanos que acudieron al Hospital Ortopédico Nacional de Enugu (Nigeria). Se extrajeron unos 3 ml de sangre venosa de la fosa antecubital siguiendo técnicas asépticas en recipientes con EDTA para las determinaciones del hemograma. Los recuentos sanguíneos completos de los sujetos se determinaron utilizando el Mindray BC-3000 Plus. Los datos se analizaron mediante la prueba de la t de Student y se presentaron como media \pm desviación estándar utilizando el SPSS versión 20 y el nivel de significación se fijó en $P < 0,05$.

Resultados: El estudio mostró un aumento de los glóbulos rojos, la hemoglobina y el volumen celular empaquetado de los hombres en comparación con las mujeres.

Conclusiones: Se aconseja a la sociedad que reduzca al mínimo algunas actividades que le predispongan a sufrir fracturas mandibulares, ya que en esta parte del mundo hay pocos cirujanos con experiencia para resolver los problemas rápidamente y con el máximo bienestar de los pacientes.

Palabras clave: Género, parámetros hematológicos, inflamación, fracturas mandibulares.

Introduction

It has been reported that the incidence of maxillofacial fracture varies with population density, living environment, socioeconomic status, and road traffic conditions¹⁻⁵. It has been opined that most cases of maxillofacial trauma involve mandibular fracture, which is usually managed by departments of oral and maxillofacial surgery⁶.

The number of elderly patients with maxillofacial trauma has increased in recent decades because of changes in lifestyle and an increase in the proportion of elderly patients in the population¹. Likewise, in other developed countries, the proportion of individuals ≥ 65 years of age is expected to increase to 26.2%. With demographic and various social changes, such as the greater number of elderly living alone and leading an active retirement, the elderly population may be at increased risk for trauma, including maxillofacial fracture⁷.

It has been shown that vehicular accidents and altercations are the primary causes of mandibular fractures throughout the world. In an urban trauma setting, altercations account for most fractures (50%), and motor vehicle accidents are less likely (29%). Gender-based report has shown that Males suffer approximately three times as many mandible fractures as females, with the majority occurring in the third decade of life^{8,9}. Patients with mandibular fractures frequently have other associated injuries (43%). The most common associated injuries include head injuries (39%), head and neck laceration (30%), midface fractures (28%), ocular injuries (16%), nasal fractures (12%), and cervical spine fractures (11%)⁸.

The study was done to evaluate the hematological parameters and some inflammation marker of patients with mandibular fractures in a tertiary hospital in Southeast, Nigeria.

Materials and methods

Study area

The study was done in National Orthopedic Hospital, Enugu, Nigeria. This hospital is located in Enugu State in Nigeria. The hospital serves many people from all over Nigeria with Orthopedic cases.

Study Design

The study adopted cross-sectional hospital based design with purposive sampling technique where patients who attended the hospital with mandibular fractures were selected for the study and the hematological parameters and some inflammation markers were evaluated with the apparently healthy individuals who attended the hospital on other issues not for disease issues.

Subjects

A total of 100 subjects were selected for the study comprising of 50 patients with mandibular fracture and 50 apparently healthy individuals attended National Orthopedic Hospital, Enugu, Nigeria.

Ethical issues

Ethical approval was obtained from the institution and informed consent obtained from the subjects. The details of the study were fully explained to the subject before they gave their consent and they willing participated in the study and confidentiality assured to them.

Blood Collection and Laboratory Investigations

About 3ml of venous blood was collected from antecubital fossa following aseptic techniques into EDTA containers for FBC determinations. The full blood counts of the subjects were determined using Mindray BC-3000 Plus.

Data analysis

The data were analyzed using student t-test and present as mean \pm standard deviation using SPSS version 20 and level of significance set at $P < 0.05$

Results

Table 1: Hematological and some inflammation markers of patients with mandibular fracture and apparently healthy subjects.

Parameters	Male	Female	P-value
RBC (X10 ¹² /L)	3.67 \pm 0.13	3.24 \pm 0.14	0.001*
Hemoglobin (g/dl)	11.00 \pm 0.41	9.74 \pm 0.43	0.001*
PCV (%)	32.40 \pm 1.14	29.20 \pm 1.30	0.003*
Platelets (X10 ⁹ /L)	268.00 \pm 14.30	267.60 \pm 8.73	0.959
WBC (X10 ⁹ /L)	6.46 \pm 0.68	6.56 \pm 0.36	0.778
Neutrophils (%)	65.40 \pm 5.73	66.80 \pm 2.59	0.632
Lymphocytes (%)	26.94 \pm 5.18	25.62 \pm 2.38	0.619
Eosinophils (%)	0.66 \pm 0.84	0.38 \pm 0.08	0.519
Monocytes (%)	7.00 \pm 1.87	7.2 \pm 1.64	0.862
NLR	2.55 \pm 0.79	2.63 \pm 0.35	0.830
PLR	10.38 \pm 2.92	10.52 \pm 1.08	0.925

RBC= Red blood cell, PCV= Packed cell volume, WBC= Total white cell count, NLR= Neutrophil to lymphocyte ratio, PLR= Platelet to lymphocyte ratio

Discussion

The study showed increase in the red lines such as the red cells, hemoglobin and Packed Cell Volume of the male compared to the females. The red cell lines of males are usually higher due to hormonal differences and menstrual cycles of the females. It was noticed that there was no changes in the white cell line and platelets together with the inflammatory markers which indicates that inflammation in patients with mandibular fractures are not gender based. The red cell lines of the patients with mandibular fractures may be affected due to the impact on the bone marrow which may affect the hematopoietic activities of the bone marrows. This will have a serious effect on the survival of the patients

as some of them may be likely anemic due to bone marrow reduced activities. It has been reported that mandibular fractures are more prevalent in men than in women which may be due to nature of works men are predisposed to in Nigeria to keep their families viable financially and otherwise^{8,9}. It was also reported that mandibular fractures are more common in the aging and the elderly⁷. The society are advised to minimize some activities that will predispose them to mandibular fractures as there are limited surgeons with expertise in this part of the world to resolve the issues fast and with utmost well-being of the patients.

Conclusion

The study showed increase in the red lines such as the red cells, hemoglobin and Packed Cell Volume of the male compared to the females. The society are advised to minimize some activities that will predispose them to mandibular fractures as there are limited surgeons with expertise in this part of the world to resolve the issues fast and with utmost well-being of the patients.

Conflict of interest



None

References

1. Goldschmidt MJ, Castiglione CL, Assael LA, Litt MD. Craniomaxillofacial trauma in the elderly. *J Oral Maxillofac Surg.* 1995;53: 1145-9.
2. Brasileiro BF, Passeri LA. Epidemiological analysis of maxillofacial fractures in Brazil: a 5-year prospective study. *Oral Surg Oral Med Oral Pathol Oral Radiol Endod.* 2006;102: 28-34.
3. Bakardjiev A, Pechalova P. Maxillofacial fractures in Southern Bulgaria—a retrospective study of 1706 cases. *J Craniomaxillofac Surg.* 2007;35: 147-50.
4. Maliska MC, Lima SM Júnior, Gil JN. Analysis of 185 maxillofacial fractures in the state of Santa Catarina, Brazil. *Braz Oral Res.* 2009;23: 268-74.
5. Kloss FR, Stigler RG, Brandstätter A, Tuli T, Rasse M, Laimer K, et al. Complications related to midfacial fractures: operative versus non-surgical treatment. *Int J Oral Maxillofac Surg.* 2011;40: 33-7.
6. Sasaki R, Ogiuchi H, Kumasaka A, Ando T, Nakamura k, Ueki T, et al. Analysis of the pattern of maxillofacial fracture by five departments in Tokyo. *Oral Science International* 2008;6: 1.
7. United Nations. World population prospects: the 2008 Revision. Available: http://www.un.org/esa/population/publications/wpp2008/wpp2008_highlights.pdf#search=%27World%20Population%20Prospects:%20The%202008%20Revision.
8. Jin KS, Lee H, Sohn JB, Han YS, Jung DU, Sim HY, Kim HS. Fracture patterns and causes in the craniofacial region: an 8-year review of 2076 patients. *Maxillofac Plast Reconstr Surg.* 2018 ;40(1):29.
9. Louis M, Agrawal N, Truong TA. Midface Fractures II. *Semin Plast Surg.* 2017 May;31(2):94-9.

Investigating the toxicity of germ of date seed on normal and cancerous cell line and P53 gene expression

Investigación de la toxicidad del germen de semilla de dátil en líneas celulares normales y cancerosas y expresión del gen P53

Abbasali Mokarmat-Yazdi BSc¹ , Masoumeh Mazidi MD² ,
Mohsen Ghiasi Tarzi MSc³ , Hadi Zare-Zardini PhD^{4,5} 

1. Biology Department, Medical Biotechnology Research Center, Ashkezar Branch, Islamic Azad University, Ashkezar, Yazd, Iran.

2. Medical Education Development Center, Shahid Sadoughi University of Medical Sciences, Yazd, Iran.

3. Division of Nanobiotechnology, Department of Life Science Engineering, Faculty of New Sciences and Technologies, University of Tehran, Tehran, Iran.

4. Department of Biomedical Engineering, Meybod University, Meybod, Iran.

5. Hematology and Oncology Research Center, Shahid Sadoughi University of Medical Sciences, Yazd, Iran

Corresponding author

Hadi Zare-Zardini
E-mail: ha_zar63@yahoo.com

Received: 28 - XII - 2022

Accepted: 25 - I - 2023

doi: 10.3306/AJHS.2023.38.03.62

Abstract

In this study, the germ of Date seed was collected by breaking a thousand date kernels. These acquired germ was powdered and dissolved in distilled water for achievement of different concentrations (3.4, 1.7, 0.85, 0.425 and 0.212 mg/ml). Cancerous (MCF-7) and normal (HFF) cell lines were treated with these concentrations for 24, 48, and 72 hours. Cell viability was assessed using MTT technique. P53 gene expression was evaluated by Real time PCR technique. Results showed that in the highest concentration of germ of Date seed (3.4mg/ml), the percentage of viable cells for cancerous cell lines was 26, 30.1, 40.1% in 24, 48, and 72 hours, respectively. In this concentration, for normal cell lines, the percentage of viable cells was 36.1, 37.1, 42.1% in 24, 48, and 72 hours, respectively. In both cell line, germ of Date seed led to increase of P53 gene expression.

Key words: Date seed, Germ, Cancer, P53 Gene expression.

Resumen

En este estudio, el germen de la semilla de dátiles se recolectó rompiendo mil semillas de dátiles. Este germen adquirido fue pulverizado y disuelto en agua destilada para lograr diferentes concentraciones (3.4, 1.7, 0.85, 0.425 y 0.212 mg/ml). Las líneas celulares cancerosas (MCF-7) y normales (HFF) se trataron con estas concentraciones durante 24, 48 y 72 horas. La viabilidad celular se evaluó utilizando la técnica MTT. La expresión del gen P53 se evaluó mediante la técnica de PCR en tiempo real. Los resultados mostraron que en la mayor concentración de germen de semilla de dátil (3,4 mg/ml), el porcentaje de células viables para líneas celulares cancerosas fue de 26, 30,1, 40,1% en 24, 48 y 72 horas, respectivamente. En esta concentración, para líneas celulares normales, el porcentaje de células viables fue 36,1, 37,1, 42,1% en 24, 48 y 72 horas, respectivamente. En ambas líneas celulares, el germen de la semilla de dátil condujo a un aumento de la expresión del gen P53.

Palabras clave: Semilla de dátil, germen, cáncer, expresión del gen P53.

Introduction

Breast cancer with high frequency among women is the most important cancer worldwide^{1,2}. The survival rate for women with non-metastatic invasive breast cancer is approximately 84-90%. In recent years, incidence rates of breast cancer have increased by 0.5% per year. The average risk of a woman for developed breast cancer is 13%. This means there is a 1 in 8 chance she will develop breast cancer³. There are various strategies for treatment of breast cancer⁴. Development of complementary medicine can be useful for enhancement of current treatment. The use of natural products, especially with plant origin, have been developed in complementary medicine⁵. Date seeds as a discarded part of Dates, have unique medicinal properties such as antioxidant and antimicrobial properties, cholesterol reduction, protective effect against radiation, anti-diabetic effect, and etc.⁶⁻¹⁶. In this article, we evaluated the in vitro effect of germ of Date seed on viability and P53 gene expression in normal and cancerous cell line.

3, 1.7, 0.85, 0.425 and 0.212 mg /ml) for 24, 48 and 72 hours. After the treated period, the effect of powder on the cells was evaluated using MTT technique. For evaluation of P53 gene expression, Real time PCR technique was applied. In this section, the cells were cultured. After 24 hours, the powder of Date seed germ was added to the wells and placed in a CO2 incubator. RNA was extracted from these cells and cDNA was synthesized and the P53 gene expression against beta-actin gene was examined.

Results

Experimental procedures and acquired results are summarized in graphical abstract (**Figure 1**).

Experimental evaluation of germ of Date seed on normal and cancerous cells was summarized in **table I & II**. According to this table, different concentrations of germ of Date seed reduced the number of viable cells compared to the control group. The percentage of living cells decreased along with increases of concentration of powder. The toxicity of the powder on cancer cells was higher than normal cell line. The highest toxicity was observed for both cells at the highest concentration of powder. Increasing the duration of cell treatment led to a greater effect of the substance on the percentage of viable cells.

Materials and Methods

Human breast cancer and normal cell lines were used for evaluation of anticancer activity and P53 gene expression. These cells were cultured at suitable conditions. Cultures cells were treated with different concentrations of the powder of Date seed germ (4,

Figure 1: Graphical abstract containing experimental and result sections.

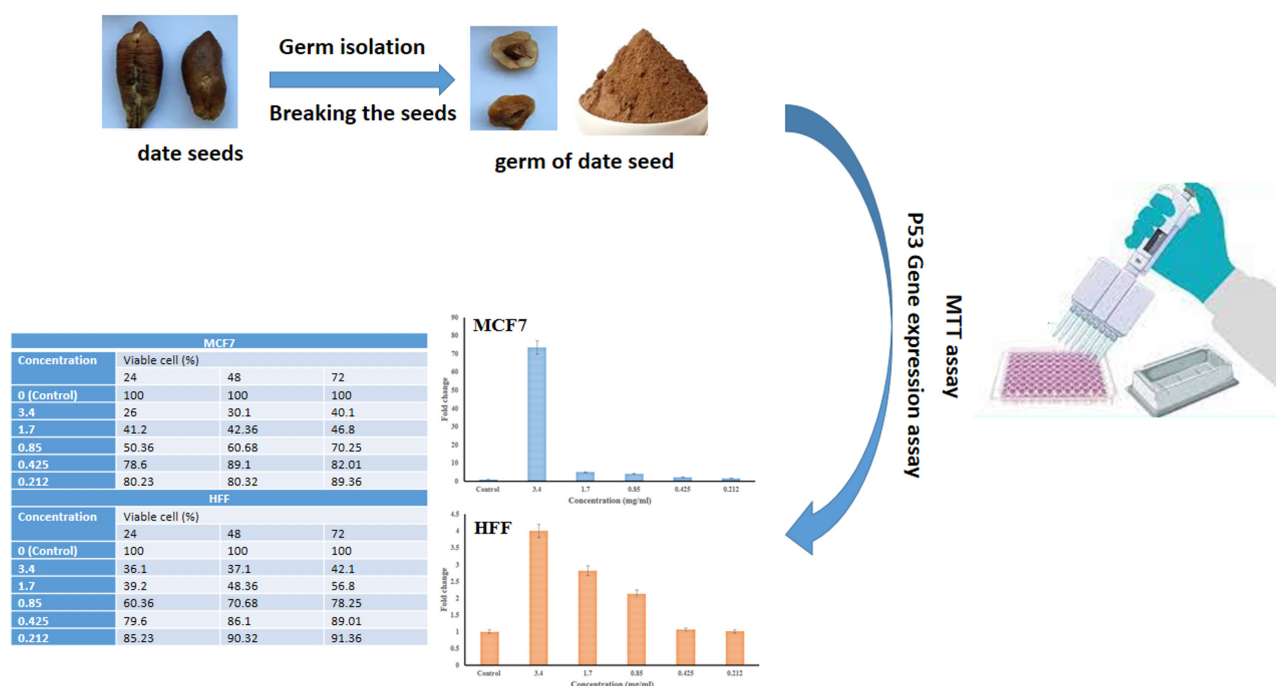

Table I: Effect of different concentrations of germ powder of Date seed on cancer cells (MCF7).

Concentration	Viable cell (%)		
	24	48	72
0 (Control)	100	100	100
3.4	26	30.1	40.1
1.7	41.2	42.36	46.8
0.85	50.36	60.68	70.25
0.425	78.6	89.1	82.01
0.212	80.23	80.32	89.36

Table II: Effect of different concentrations of germ powder of Date seed on normal cells (HFF).

Concentration	Viable cell (%)		
	24	48	72
0 (Control)	100	100	100
3.4	36.1	37.1	42.1
1.7	39.2	48.36	56.8
0.85	60.36	70.68	78.25
0.425	79.6	86.1	89.01
0.212	85.23	90.32	91.36

Figure 2 shows the results of increased P53 gene expression in both normal and cancer cell lines compared to the control group. This increase in gene expression is directly related to the concentration of powder. According to the results, the rate of increased gene expression in cancer cells was higher than normal cells. The highest concentration of powder (3.4 mg / ml) had the greatest effect on the P53 gene expression. This effect was observed in both normal and cancer cells.

Figure 1: Effect of different concentrations of germ powder of Date seed on P53 gene expression in cancer (A) and normal (B) cells.

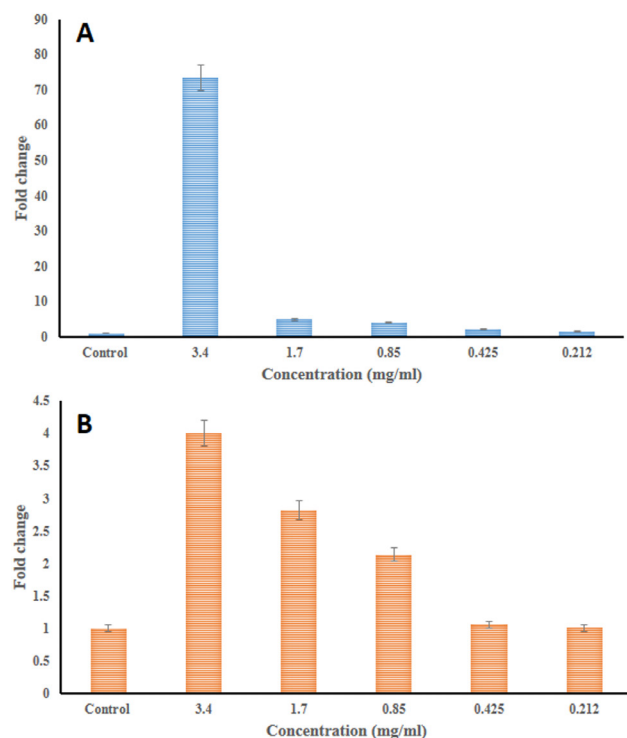

Discussion

The p53 gene is considered as the most common and major gene that mutates in various tumors¹⁷. This gene, as an essential marker, plays an important role in the clinical diagnosis of tumors¹⁸. The researchers first identified the P53 gene as a type of cancer protein antigen, then as a cancer gene and finally as a tumor-inhibiting gene¹⁹. Research has shown that the wild-type p53 gene is a tumor-inhibiting gene, and mutations in the p53 gene can lead to tumorigenesis²⁰. Therefore, any combination that can alter the expression of this gene can be considered as one of the therapeutic goals in the field of cancer²¹⁻²³. Meanwhile, research on natural materials and compounds is gaining more and more attention. Date seeds are a discarded part of Dates. But the results of various studies have shown that these Dates have unique medicinal properties⁶⁻⁹. Analysis of the constituents of Date seed has shown that this part of Dates contains more than 80% carbohydrates, about 15% oils and approximately 5% protein¹⁰. There are also various nutrients in Date seeds. The antioxidant and antimicrobial properties of Date seed powder have been proven in various studies¹¹⁻¹³. Effect of Date seed powder on cholesterol reduction in mice, effect on blood and biochemical parameters and some fertility indices, protective effect against radiation, especially gamma radiation, anti-diabetic effect, protective effect on liver and kidney function, efficacy in cerebral ischemia and etc. were proven in various studies¹⁴⁻¹⁶. Acquired powders from whole Date seed have been used in various articles and acceptable results have been obtained in terms of biological effects, but no studies have been performed on germ of Date seed. In this study, the anti-cancer effect of germ powder and its related p53 gene expression was evaluated on breast cancer cell line. The results showed that the germ powder led to cell death in both normal and cancer cells, but the toxicity of the powder was higher on cancer cells. Based on the obtained results, the toxicity effect of germ powder is dose-dependent and the survival rate of cancer cells was significantly reduced at concentrations higher than 3 mg/ml. The results of the gene expression study also showed that the extract, increased P53 gene expression was occurred in both normal and cancer cells compared with the control. The effect of germ powder on increasing gene expression was greater in cancer cells than normal cells.

Conflict of interest

None

References

1. Akram M, Iqbal M, Daniyal M, Khan AU. Awareness and current knowledge of breast cancer. *Biological research*. 2017;50(1):1-23.
2. McKinney SM, Sieniek M, Godbole V, Godwin J, Antropova N, Ashrafian H, et al. International evaluation of an AI system for breast cancer screening. *Nature*. 2020;577(7788):89-94.
3. Siegel RL, Miller KD, Jemal A. Cancer statistics, 2020. *CA: a cancer journal for clinicians*. 2020;70(1):7-30.
4. Waks AG, Winer EP. Breast cancer treatment: a review. *Jama*. 2019;321(3):288-300.
5. Mokarramat-Yazdi A, Soltaninejad H, Zare-Zardini H, Shishehbor F, Alemi A, Fesahat F, et al. Investigating the anticancer effect of a new drug originating from plant and animal: In vitro and in vivo study. *Journal of Advanced Pharmacy Education & Research* | Apr-Jun. 2020;10(S2):73.
6. Maqsood S, Adiamo O, Ahmad M, Mudgil P. Bioactive compounds from date fruit and seed as potential nutraceutical and functional food ingredients. *Food chemistry*. 2020;308:125522.
7. Mrabet A, Jiménez-Araujo A, Guillén-Bejarano R, Rodríguez-Arcos R, Sindic M. Date seeds: A promising source of oil with functional properties. *Foods*. 2020;9(6):787.
8. Roslan NS, Rahim NS, Razali Z, Zulkifli MA. Anti-microbial Properties and Toxicity Test of Stingless Bee Honey (*Trigona itama*), Ajwa Date (*Phoenix dactylifera L.*) Seeds and Their Combinations. *Charting the Sustainable Future of ASEAN in Science and Technology: Springer*; 2020. p. 155-66.
9. Abdulrahman LNMA. Impacts of Date Palm Seeds (*Phoenix Dactyliferous L.*) on Common Carp (*Cyprinus Carpio L.*). *Biological Indices and Blood Pictures*. EXECUTIVE EDITOR. 2020;11(01):1910.
10. Ataye SE, Hadad KM, Lame S, Habibi NM, Fatemi S. Determination of chemical composition and fatty acids profile of date seed. 2011.
11. Saryono S, editor Date seeds drinking as antidiabetic: a systematic review. *IOP Conference Series: Earth and Environmental Science*; 2019: IOP Publishing.
12. Metoui M, Essid A, Bouzoumita A, Ferchichi A. Chemical Composition, Antioxidant and Antibacterial Activity of Tunisian Date Palm Seed. *Polish Journal of Environmental Studies*. 2019;28(1).
13. Ardekani MRS, Khanavi M, Hajimahmoodi M, Jahangiri M, Hadjikhooondi A. Comparison of antioxidant activity and total phenol contents of some date seed varieties from Iran. *Iranian journal of pharmaceutical research: IJPR*. 2010;9(2):141.
14. Abou-Zeid SM, El-Bialy BE, El-Borai NB, AbuBakr HO, Elhadary AMA. Radioprotective effect of date syrup on radiation-induced damage in rats. *Scientific reports*. 2018;8(1):1-10.
15. Habib H, Othman A, Al-Marzooqi S, Al-Bawardi A, Pathan JY, Hilary S, et al. The antioxidant activity of date seed: preliminary results of a preclinical in vivo study. *Emirates Journal of Food and Agriculture*. 2017:822-32.
16. Saryono S, Proverawati A. Hepatoprotective effect of date seeds works through the antioxidant mechanism: a systematic review. *Annals of Tropical Medicine and Health*. 2019;22:301-9.
17. Ma Y-S, Shi Y, Liu J-B, Wu T-M, Jia C-Y, Yang H-Q, et al. Targeting long non-coding RNA to therapeutically regulate gene expression in cancer. *Molecular Therapy-Nucleic Acids*. 2020.
18. Puetkasichonpasutha J, Namwat N, Sa-Ngiamwibool P, Titapun A, Suthiphongchai T. Evaluation of p53 and Its Target Gene Expression as Potential Biomarkers of Cholangiocarcinoma in Thai Patients. *Asian Pacific journal of cancer prevention: APJCP*. 2020;21(3):791.
19. Graziano SL, Tatum A, Herndon II JE, Box J, Memoli V, Green MR, et al. Use of neuroendocrine markers, p53, and HER2 to predict response to chemotherapy in patients with stage III non-small cell lung cancer: a Cancer and Leukemia Group B study. *Lung Cancer*. 2001;33(2-3):115-23.
20. Maniwa Y, Yoshimura M, Obayashi C, Inaba M, Kiyooka K, Kanki M, et al. Association of p53 gene mutation and telomerase activity in resectable non-small cell lung cancer. *Chest*. 2001;120(2):589-94.
21. Tamura RE, Lana MG, Costanzi-Strauss E, Strauss BE. Combination of cabazitaxel and p53 gene therapy abolishes prostate carcinoma tumor growth. *Gene therapy*. 2020;27(1):15-26.
22. Roshankhah S, Arji Rodsari B, Jalili C, Salahshoor MR. The Role of Harmine in Up-regulating p53 Gene Expression and Inducing Apoptosis in MCF-7 Cell Line. *Middle East Journal of Cancer*. 2020;11(1):34-41.
23. Duffy MJ, Synnott NC, O'Grady S, Crown J, editors. Targeting p53 for the treatment of cancer. *Seminars in Cancer Biology*; 2020: Elsevier.

The knowledge and attitudes of nursing students towards nosocomial infections in Morocco

Los conocimientos y las actitudes de los estudiantes de enfermería hacia las infecciones nosocomiales en Marruecos

Mohamed Amine Baba^{1,2,5} , Ahmed Kharbach^{3,6}, Abderrahmane Achbani^{4,8}, Aziz Naciri⁷, Mohamed Nejmeddine⁴

1. Laboratory of Health Sciences Research, Ibn Zohr University, 80000 Agadir, Morocco

2. Faculty of Medicine and Pharmacy of Agadir, Ibn Zohr University, 80000 Agadir, Morocco

3. Laboratory of Biostatistics, Clinical Research and Epidemiology (LBRCE), Faculty of Medicine and Pharmacy of Rabat, Mohammed V University of Rabat, Rabat, Morocco.

4. Laboratory of Cell Biology and Molecular Genetics, Department of Biology, Faculty of Sciences, University Ibn Zohr, Agadir, Morocco.

5. Higher Institute for Nursing Professions and Health Techniques, Agadir, Morocco

6. Higher Institute for Nursing Professions and Health Techniques, Guelmim, Morocco

7. Higher Institute for Nursing Professions and Health Techniques, Laayoun, Morocco

8. Higher Institute for Nursing Professions and Health Techniques, Marrakech, Morocco

Corresponding author

Mohamed Amine Baba

E-mail: Babamohamedamine2@gmail.com

Received: 30 - XII - 2022

Accepted: 26 - I - 2023

doi: 10.3306/AJHS.2023.38.03.66

Abstract

Introduction: Learning about nosocomial infections is an essential component for improving measures against these infections and for developing effective preventive and curative strategies. The objective of this study is to evaluate the level of knowledge of nursing students at the Higher Institute of Nursing Professions and Health Techniques of Agadir.

Method: This is a cross-sectional self-administered questionnaire for students in the care sector.

Results: One hundred fifty-nine students participated in this study. The average general knowledge score was 3.42 ± 1.50 . The mean knowledge of practices and attitudes score was 11.50 ± 3.42 . The total mean score was 14.92 ± 5.007 . We found that the total score was better in students trained in nosocomial infections ($P < 0.05$). The versatile nurse option recorded the best knowledge scores compared to the other options. The definition of nosocomial infection and its mode of transmission of germs by the hands not identified by more than half of the students. Bacteria were the most cited microbial agent in relation to nosocomial infections. The regulatory aspect of nosocomial infection has been overlooked by most students. Managing feces and preventing blood exposure accidents are the most overlooked standard precautions.

Conclusion: A low level of knowledge of nosocomial infections was observed. Similarly, we should note a difference in the knowledge score between the trained and untrained groups. In conclusion, we propose a teaching of generalization of nosocomial infection for nursing training at the Higher Institute of Nursing Professions and Health Techniques of Agadir.

Key words: Knowledge, attitudes, practices, Nosocomial infections, Nursing care.

Resumen

Introducción: El aprendizaje de las infecciones nosocomiales es un componente esencial para mejorar las medidas contra estas infecciones y para desarrollar estrategias preventivas y curativas eficaces. El objetivo de este estudio es evaluar el nivel de conocimientos de los estudiantes de enfermería del Instituto Superior de Profesiones de Enfermería y Técnicas Sanitarias de Agadir.

Método: Se trata de un cuestionario transversal autoadministrado a los estudiantes del sector asistencial.

Resultados: Ciento cincuenta y nueve estudiantes participaron en este estudio. La puntuación media de los conocimientos generales fue de $3,42 \pm 1,50$. La puntuación media de conocimientos de prácticas y actitudes fue de $11,50 \pm 3,42$. La puntuación media total fue de $14,92 \pm 5,007$. Encontramos que la puntuación total fue mejor en los estudiantes formados en infecciones nosocomiales ($P < 0,05$). La opción de la enfermera versátil registró las mejores puntuaciones de conocimiento en comparación con las otras opciones. La definición de infección nosocomial y su modo de transmisión de gérmenes por las manos no fue identificada por más de la mitad de los estudiantes. Las bacterias fueron el agente microbiano más citado en relación con las infecciones nosocomiales. El aspecto normativo de la infección nosocomial ha sido pasado por alto por la mayoría de los estudiantes. El manejo de las heces y la prevención de los accidentes de exposición a la sangre son las precauciones estándar más olvidadas.

Conclusión: Se ha observado un bajo nivel de conocimientos sobre las infecciones nosocomiales. Asimismo, se observa una diferencia en la puntuación de conocimientos entre los grupos formados y no formados. En conclusión, proponemos una enseñanza de generalización de la infección nosocomial para la formación de enfermería en el Instituto Superior de Profesiones de Enfermería y Técnicas Sanitarias de Agadir.

Palabras clave: Conocimientos, actitudes, prácticas, infecciones nosocomiales, cuidados de enfermería.

Introduction

Infections that occur in hospitals are referred to as hospital-associated infections. These infections are also called "nosocomial infections" and sometimes "hospital acquired infections". As ambulatory care is increasingly given to outpatients, it is also referred to as healthcare-associated infections¹.

Nosocomial infections represent a real public health problem, because of their frequency, their severity, and also their socioeconomic cost². In addition, the infection contracted in the hospital environment is the result of the dispensation of unsafe care³. In the same perspective, the World Health Organization (WHO) revealed that on average 8.7% of hospitalized patients had acquired a nosocomial infection and that Developing countries would be up to 20 times more likely to contract a nosocomial infection than developed countries⁴.

In Morocco and according to WHO, the prevalence rate of nosocomial infection is 17.8%⁵. Although infection is more common in patients upon admission, healthcare professionals also act as potential carriers of pathogens.

Hospitals provide a favorable transmission route for the spread of nosocomial infections, in part because of poor infection control practices among healthcare workers and overcrowding of patients in most clinical settings⁶. The factors of these infections are generally multiple, namely, environmental factors such as the cleanliness of instruments, floors and walls and resistance to antimicrobials, as well as factors related to the knowledge and attitudes of health personnel in terms of infection prevention⁷.

As a result, and to deal with these factors which are linked to the knowledge of personnel, the World Health Organization (WHO) recommends programs for the fight against nosocomial infections for which must be very complete and cover both activities monitoring and prevention as well as staff training. In this regard, prevention and monitoring alone do not guarantee their reduction without resorting to good training for caregivers. In this sense, a study is carried out in western Algeria revealed that the lack of respect for standard precautions which aim to prevent the transmission of infectious agents by blood and bodily fluids was mainly due to a lack of knowledge⁸.

One of the components of caregivers are nursing students who are exposed to the hospital environment during their clinical internship and who are required to provide care to patients, regardless of their disease status⁹, thus the limited clinical experience of novice nurses with regard to the usual precautions, their lack of knowledge of the use of personal protective equipment, as well as insufficient training in clinical procedures are contributing factors to the increased risk of nosocomial infections⁹.

Cross-sectional surveys of nursing students in Africa showed that the majority of this population had poor knowledge, attitudes and practices regarding nosocomial infection control measures¹⁰, and that a structured educational program was needed¹¹.

The place of nursing students in the patient safety process and also in ensuring their own protection during training courses remains little explored in Morocco. With this in mind, this work aims to assess the knowledge and attitudes of students in the nursing care sector on the risk of infection and on the rules of precaution and hand hygiene and barriers to ensure patient safety as well as self-protection of student nurses.

Methods

This is a descriptive, cross-sectional study that took place at the Higher Institute of Nursing Professions and Health Techniques of Agadir. Target population was students in the care sector which includes five options: Polyvalent Nurse, Anesthesia and Resuscitation Nurse, Family and Community Health Nurse, Mental Health Nurse and Emergency and Intensive Care Nurse. They are included in this study. Students enrolled in the spring session of semester four and semester six of the current year. The total number of students enrolled was 169 students, and the sampling in the present study was exhaustive.

Data collection

A self-administered questionnaire was used to assess students' knowledge. This questionnaire was sent to all students in the Nursing department present on the day of the survey. The questionnaire comprised 27 questions divided into two sections: i) general knowledge of healthcare-associated infections. ii) knowledge of attitudes and practices for the prevention of nosocomial infections. A repository of recommendations updated in 2017 for the surveillance and prevention of healthcare-associated infections was used to identify the different variables.

Knowledge score

A Knowledge Score was used to assess general knowledge and knowledge of attitudes and practices regarding nosocomial infections.

We set a knowledge score as follows. A total score noted out of 30, including 10 points on general knowledge of nosocomial infections and 20 points on knowledge of attitudes and practices for the prevention of nosocomial infections. A total score interpretation scale was presented as follows:

- A total score of 0 to 9 is considered as level of knowledge: Low

- A total score of 10 to 19 is considered as level of knowledge: Medium
- A total score of 20 to 30 is considered as level of knowledge: Good

Statistical analysis

The data collected was analyzed using the “SPSS.13” software, The margin of error is calculated for a confidence level of 95%, The quantitative variables were expressed as the mean ± the standard deviation. The variables qualitative are presented by tables of frequencies and frequencies. The Chi-square test was used for the correlation between the qualitative variables and the ANOVA test was used for the correlation between the quantitative variables.

Ethical consideration

The authorization of the Higher Institute of Nursing Professions and Health Technologies was obtained to conduct the study. Consent was obtained from the students for their participation in the study. The collection, entry and processing of data were done while respecting the anonymity of the participants.

Results

Participant characteristics

As part of this survey, one hundred and fifty-nine students in the Nursing sector (n=159) were questioned. That is a participation rate of 94.1 %. The analysis of the results showed an average age of the participants of 20.74 years ± 1.04 with a minimum age of 18 years and a maximum age of 25 years. A female predominance with a sex ratio of 0.35.

According to the analysis of the training descriptions of the Nursing Care options, 76 students, or 47.79%, took a course on nosocomial infections as part of their basic training.

Knowledge Score

The majority of students 88.7%, obtained an unsatisfactory general knowledge score (<5). In addition, half of the students had an Attitudes and Practices score below the average (<10). Overall, the total score was less than or equal to 15 in 58% of students (Table I)

The average of the general knowledge in all the options of the care sector is below the average of the note of this fixed already (5/10), of this fact the totality of the students of the care sector do not have a good level related to general knowledge.

For The score of knowledge in attitudes and practices of prevention of nosocomial infections was higher among students of the general nursing option compared to the other options, more precisely the nursing option in emergency care and intensive care and the mental health option.

The total score follows the same previous results, and shows a very high knowledge score among students of the general nursing option and the family and community health nursing option. However, students who had already undergone training in nosocomial infection obtained

Table I: Characteristics of participants.

Variables	F (%)
Sexe	
F	117
M	42
Age (M ±SD)	20,74 ans ± 1,04
Option	
Polyvalent Nurse (PN)	52 (32,7)
Anesthesia and Resuscitation Nurse (ARN)	35(22,0)
Family and Community Health Nurse (FCHN)	24 (15,1)
Emergency and Intensive Care Nurse (NEIC)	35(22,0)
Mental health nurse (MHN)	13(8,2)
Score	
General knowledge score (M ±SD) ‡	3,42 ± 1,50
Knowledge of attitudes and practices score £	11,50 ± 3,86
Total score ¥	14,92 ± 5,01

‡ General knowledge score is scored out of 10; £ knowledge of attitudes and practices score is scored out of 20; ¥ total score is noted out of 30.

Table II: Distribution of student knowledge scores according to option, training and number of internships.

	General knowledge score Mean ±SD	Knowledge of attitudes and practices score Mean ±SD	Total score Mean ±SD
Options:			
PN	4,90 ± 1,14	15,79 ±1,78	20,69 ±2,02
ARN	2,40 ± ,97	8,71 ±2,21	11,14 ±2,64
FCHN	2,83 ±1,27	11,83 ±3,01	14,66 ±4,11
MHN	2,91 ± ,95	8,77 ±2,30	11,68 ±2,80
NEIC	2,69 ±1,10	8,54 ±1,80	11,23 ±2,58
Follow-up of training in nosocomial infection			
Oui	4,25 ± 1,52	14,54 ±2,89	18,78 ±3,99
Non	2,66 ± 1,01	8,71 ±2,17	11,38 ±2,68
Number of Hospital internships			
≤ 3	3,77 ± 1,50	12,81 ±3,71	6,56 ±4,76
Between 4 and 5	3,28 ± 1,45	10,57 ±3,68	13,88 ±4,83
> 5	2,08 ± ,76	8,46 ±2,53	10,53 ±3,12

PN: Versatile Nurse, ARN: Nurse in Anesthesia and Resuscitation, FCHN: Family Health and Community Health Nurse, MHN: Mental Health Nurse, NEIC: Nurse in Emergency and Intensive Care.

better scores for general knowledge, a knowledge score for attitudes and practices in the prevention of nosocomial infections and a total score, compared to untrained students. (Table II).

The appreciation of the knowledge of the nursing students on the nosocomial infection concerned the definition of this one, the factors, the reservoir, the susceptible host, the modes of transmission and the germs responsible for this infection.

The definition of IN was correct in half of the students in the care sector with a majority of correct answers in the students of the polyvalent option and a majority of incorrect answers in the mental health option. with a significant difference compared to the different options of the students. ($p < 0,001$) (Table III).

The transmissible nature of the nosocomial infection is well known in 92.5% of cases. For the hand-carrying mode of transmission only the general-purpose nurses who have a significant percentage of the correct answers, on the other hand for almost all the students

Nurse in emergency care and intensive care and Nurse in family health and community health the importance of the role of the hand in the occurrence of nosocomial infections is ignored, as well as for the reservoir of this infection most of the students of the option anesthesia and resuscitation and emergency care and intensive care declared incomplete answers.

There is also poor knowledge of students vis-à-vis the host and the reservoir of the nosocomial infection. Regarding the microbial agents responsible for nosocomial infection, the majority of students linked nosocomial infection especially to bacterial agents, however the virus is rarely mentioned in most of the answers, especially among students in emergency care and intensive care. The recommendation of the nature of the gown that the caregiver should wear was not known by the majority of ARN and FCHN students compared to the students of the PN option, 92.30% of whom declare a good knowledge of this attitude (Table III).

The students of the care sector surveyed have a good knowledge of the interest of applying standard

Table III: Distribution of general knowledge according to options.

Questions	PN (n)	ARN (n)	FCHN (n)	MHN (n)	NEIC (n)	P value
Definition of NI						< 0 ,001
True	50	15	12	06	09	
False	02	20	12	29	04	
Declared NI factors:						0,003
≤ 2 factors	16	10	17	22	09	
> 2 factors	35	21	07	12	04	
No factor	01	04	00	01	00	
Handheld transmission mode						< 0 ,001
True	35	06	02	08	03	
False	17	29	22	27	10	
The NI is not transmissible						0,131
True	01	03	04	04	00	
False	51	32	20	31	13	
Receptive host of NI						0,469
Complete answer	28	14	13	16	04	
Incomplete answer	24	21	11	19	09	
Reservoir of NI						0,034
Complete answer	32	09	12	12	04	
Incomplete answer	19	26	12	23	09	
Bacteria is responsible for NI						0,079
True	50	29	22	34	13	
False	02	06	02	01	00	
Virus is responsible for NI						< 0 ,001
True	48	11	05	11	02	
False	04	24	19	24	11	
Parasite is responsible for NI						< 0 ,001
True	43	21	07	25	08	
False	09	14	17	10	05	
Champignon is responsible for NI						0,002
True	38	19	8	12	07	
False	14	16	16	23	06	
The shape of the blouse recommended						< 0 ,001
Short sleeve blouse	48	11	04	18	07	
Long sleeve blouse	04	48	20	17	06	

PN: Versatile Nurse, ARN: Nurse in Anesthesia and Resuscitation, FCHN: Family Health and Community Health Nurse, MHN: Mental Health Nurse, NEIC: Nurse in Emergency and Intensive Care.

precautions to protect all patients and all health personnel (Chi-square value of 0.002). Almost all of the students in the section consider hand hygiene among the standard precautions for the management of excreta. We note a low knowledge of this measure by the students with a flagrant figure among the students of the intensive care and primary care option. emergencies where no one cited this as a standard precaution.

Regarding the indications for hand hygiene, they were well known in half of the general-purpose nursing students, compared to the other options who have little knowledge, especially the students of the intensive care and emergency care option.

For the attitude recommended for wearing gloves, we note a low knowledge among students of the mental health option, the majority of whom declare that it is recommended to keep them on between the two treatments. Washing hands before wearing gloves was well known in almost all student responses from all options (Table IV).

Discussion

Nosocomial infections are found all over the world. They are one of the main causes of mortality and morbidity in hospitalized patients. This type of infection represents a significant burden for both patients and public health¹.

Several observations were made based on the assessment of the state of knowledge of our student community and our results corroborate those found in other studies carried out at the international level. The main revelations were in favor of a better total knowledge score among students who had already undergone basic training in nosocomial infection. The same result was obtained in recent research which showed an improvement in the knowledge of students participating in an online training module on standard precautions for the prevention of nosocomial infections¹².

Compared to the level of knowledge according to the semester, the general score is high among students in semester four compared to the sixth semester, something that may call into question the question of memorization of course content related to nosocomial infections among the latter. As for the different knowledge inherent in attitudes and practices, a better score was noted among students in the sixth semester. This could be explained by the number of internships in higher clinical settings compared to fourth semester students. This is in agreement with a similar study which showed that among nurses, the score of attitudes and practices increases proportionally with the years of practice¹³.

Regarding general knowledge, more than half of the students gave a correct definition of nosocomial infections. The transmissible nature of the nosocomial infection was well known by almost all of the participants (92.5%). These results are similar with other studies

Table IV: Distribution of knowledge about attitudes and practices according to the options.

Questions	PN (n)	ARN (n)	FCHN (n)	MHN (n)	NEIC (n)	P value
Interest of standard precautions						0,002
True	48	31	14	25	12	
False	04	04	10	09	01	
Standard precautions include:						
Hand hygiene						0,013
True	50	26	23	28	12	
False	02	09	01	07	01	
Excreta management						< 0,001
True	22	02	03	09	00	
False	30	33	21	26	13	
Environment management						0,040
True	37	15	13	25	09	
False	15	20	11	10	04	
Prevention of healthcare exposure accidents						0,229
True	25	10	09	15	08	
False	27	25	15	20	105	
Indications for hand hygiene						< 0,001
True	35	09	08	13	02	
False	17	26	16	20	11	
Keep the gloves between two treatments						< 0,001
True	07	10	10	24	09	
False	45	25	14	11	04	
Hand washing is required before wearing the gloves						0,007
True	46	19	16	22	10	
False	06	16	08	13	03	

PN: Versatile Nurse, ARN: Nurse in Anesthesia and Resuscitation, FCHN: Family Health and Community Health Nurse, MHN: Mental Health Nurse, NEIC: Nurse in Emergency and Intensive Care.

which have concluded a percentage of 98% of good answers regarding nosocomial infection as well as a satisfactory level of knowledge of the definition of a nosocomial infection among nursing students in Africa¹⁴, on the other hand, a modest level was noted with regard to the epidemiological chain was listed according to our investigation. Something which is also corroborated by the study of Kra et al¹⁴. It is therefore clear that it will be difficult for these nursing students to undertake preventive actions if they have knowledge gaps in the epidemiological chain and the modes of transmission.

furthermore, the manual transmission mode was recognized by only one third of the students. However, this percentage is much higher than that described by Kra and collaborators who mentioned only 6%¹⁴. The importance of the role of the hand in the occurrence of nosocomial infections is well underlined in the literature, it is estimated that 30% to 40% of nosocomial infections are due to hand-borne transmission of an infectious agent¹⁵.

In the present study, the majority of students evoked the bacterium as the microbial agent responsible for the nosocomial infection while 51.6% did not designate the virus. This is consistent with a similar study showing a good knowledge of nursing students, especially bacterial agents compared to other agents responsible for nosocomial infection¹⁴.

Almost all of the students in the care sector do not know the committee for the fight against nosocomial infections as the body responsible for the prevention of nosocomial infections in hospital structures. On the other hand, another study has shown that this instance is correctly recognized by a third of students¹⁶. This finding could be explained in our context by the non-integration of the regulatory aspect related to nosocomial infection in the course taught to students.

The integration of standard precautionary measures for prevention against NI is of crucial importance in the daily practice of nursing professionals in order to ensure their protection and that of their patients¹⁷. In this regard, the majority of student responses linked the interest of standard precautions with the protection of patients and all healthcare personnel. The same results were obtained in another study, which revealed a high rate of between 60% and 90% of correct answers on the interest of standard precautions¹⁸.

the present survey also revealed low student knowledge of excreta management and respiratory hygiene, as two standard precautionary measures, even among students

who had previous training in nosocomial infection. This can be explained by the non-updating of the content taught.

Knowing that wearing gloves does not exclude hand washing, then the students participating in the present study showed a good knowledge in this direction which is in agreement with another study carried out with novice nurses¹³. The caregiver blouse should be understated, comfortable, ergonomic with short sleeves, so almost 44.7% failed to meet the nature of the gown recommended for caregivers, unlike the study by Hien et al. which found showed that 87.5% of nursing students mentioned a correct answer¹³.

Conclusion

The results of this study made it possible to highlight an unsatisfactory level in terms of nosocomial infections. compared to the formed group. The integration of theoretical and clinical training modules is very important in order to anchor good practices and attitudes in the prevention and fight against nosocomial infections in the current practice of nursing students. Similarly, continuing education programs, through the organization of seminars, symposia or workshops for the benefit of student trainees also remains essential in order to follow the news with regard to the latest recommendations of learned societies. Indeed, more efforts are needed to improve or revise training curricula so that the knowledge of nursing students on infection prevention and control is improved.

Said investigation was limited by the evaluation of the behavioral and attitudinal aspect only on the theoretical level. As a result, other studies on the evaluation of behaviors and attitudes of students in terms of NI on the empirical level via participant observation, proves to be very crucial to demystify the hidden facet of the current practices of nursing trainees in the various hospital internship sites.

Declaration of conflicting interests

The author(s) declared no potential conflicts of interest with respect to the research, authorship, and/or publication of this article.

Funding

The author(s) received no financial support for the research, authorship, and/or publication of this paper.

References

1. Mehta Y, Gupta A, Todi S, Myatra S, Samaddar DP, Patil V, Bhattacharya PK, Ramasubban S. Guidelines for prevention of hospital acquired infections. *Indian J Crit Care Med*. 2014 Mar;18(3):149-63. doi: 10.4103/0972-5229.128705.
2. Organisation mondiale de la Santé 2018 . Available at: Un soin propre est un soin plus sûr - IDC Medical (idc-medical.com)
3. Allegranzi B, Bagheri Nejad S, Combescure C, Graafmans W, Attar H, Donaldson L, et al. Burden of endemic health-care-associated infection in developing countries: systematic review and meta-analysis. *Lancet*. 2011 Jan 15;377(9761):228-41. doi: 10.1016/S0140-6736(10)61458-4.
4. WHO 2005. Recommandations OMS pour l'hygiène des mains au cours des soins (version avancée): synthèse: des mains propres sont des mains sûres. Available at: <https://apps.who.int/iris/handle/10665/69144>
5. WHO Guidelines on Hand Hygiene in Health Care: First Global Patient Safety Challenge Clean Care Is Safer Care. Geneva: World Health Organization; 2009.
6. Samuel SO., Kayode OO, Musa OI, Nwigwe GC, Aboderin AO, Salami TAT, et a. Nosocomial infections and the challenges of control in developing countries. *African Journal of Clinical and Experimental Microbiology* 2010; 11(2):102-10.
7. Ward DJ. The role of education in the prevention and control of infection: a review of the literature. *Nurse Educ Today*. 2011 Jan;31(1):9-17. doi: 10.1016/j.nedt.2010.03.007.
8. Beghdadli B, Belhadj Z, Chabane W, Ghomari O, Kandouci AB, Fanello S. Respect des "précautions standards" par le personnel infirmier d'un centre hospitalo-universitaire de l'ouest algérien. *Sante Publique*. 2008 Sep-Oct;20(5):445-53. doi: 10.3917/spub.085.0445.
9. AL-Rawajfah OM, Tubaishat A. Nursing students' knowledge and practices of standard precautions: A Jordanian web-based survey. *Nurse Educ Today*. 2015 Dec;35(12):1175-80. doi: 10.1016/j.nedt.2015.05.011.
10. Ojulong J, Mitonga KH, lipinge SN. Knowledge and attitudes of infection prevention and control among health sciences students at University of Namibia. *Afr Health Sci*. 2013 Dec;13(4):1071-8. doi: 10.4314/ahs.v13i4.30.
11. Thakker VS, Jadhav PR. Knowledge of hand hygiene in undergraduate medical, dental, and nursing students: A cross-sectional survey. *J Family Med Prim Care*. 2015 Oct-Dec;4(4):582-6. doi: 10.4103/2249-4863.174298.
12. Hassan ZM. Improving knowledge and compliance with infection control Standard Precautions among undergraduate nursing students in Jordan. *Am J Infect Control*. 2018 Mar;46(3):297-302. doi: 10.1016/j.ajic.2017.09.010.
13. Hien H, Drabo M, Ouédraogo L, Konfé S, Sanou D., Zéba S, et al. Connaissances et pratiques des professionnels de santé sur le risque infectieux associé aux soins: étude dans un hôpital de district au Burkina Faso. *Santé Publique* 2013; 25(2), 219-26.
14. Kra O, Aoussi E, Ehui I, Ouattara B, Bissagnéné E. S-10 Attitudes, connaissances et pratiques des élèves infirmiers face aux infections nosocomiales à Abidjan (Côte d'Ivoire). *Medicine et Maladies Infectieuses* 2009; 39:S77-S78.
15. Loczenski B. Hygiene in der Pflege--Teil 1: Hände können unsichtbare Gefahren verbreiten [Hygiene in nursing-- 1: Hands can transmit invisible dangers]]. *Pflege Z*. 2005 Jul;58(7):432-4. German.
16. Chevalier B, Margery J, Wade B, Ka S, Diatta B, Gueye M, et al. Perception du risque nosocomial parmi le personnel hospitalier de l'Hôpital Principal de Dakar. *Med Trop (Mars)*. 2008 Dec;68(6):593-6.
17. Liu LM, Curtis J, Crookes PA. Identifying essential infection control competencies for newly graduated nurses: a three-phase study in Australia and Taiwan. *J Hosp Infect*. 2014 Feb;86(2):100-9. doi: 10.1016/j.jhin.2013.08.009.
18. Rahiman F, Chikte U, Hughes GD. Nursing students' knowledge, attitude and practices of infection prevention and control guidelines at a tertiary institution in the Western Cape: A cross sectional study. *Nurse Educ Today*. 2018 Oct;69:20-25. doi: 10.1016/j.nedt.2018.06.021.

ORIGINAL

La autoestima como agente protector del síndrome de agotamiento emocional en docentes de Quito, Ecuador

Self-esteem as a protective agent of emotional exhaustion syndrome in teachers from Quito, Ecuador

Darwin Raúl Noroña Salcedo , Vladimir Vega Falcón 

Universidad Regional Autónoma de los Andes (UNIANDES), Ecuador

Corresponding author

Vladimir Vega Falcón
E-mail: vega.vladimir@gmail.com

Received: 2 - I - 2023

Accepted: 1 - II - 2023

doi: 10.3306/AJHS.2023.38.03.73

Resumen

Objetivo: El objetivo de la investigación fue determinar cómo la autoestima previene la aparición de la despersonalización, agotamiento emocional y la falta de realización en docentes de tres institutos tecnológicos superiores de la ciudad de Quito, Ecuador.

Métodos: Estudio transversal, observacional, prospectivo y analítico, correspondiente al nivel relacional. Se aplicaron dos encuestas a una muestra de 221 docentes, la primera el Maslash Burnout Inventory (MBI-Ed) para evaluar el síndrome de agotamiento emocional, y el cuestionario de autoestima "IGA-2000". La hipótesis de investigación dictaminaba existencia de correlación negativa entre autoestima y burnout. Para el análisis inferencial se utilizó la prueba Chi cuadrado de Spearman con un nivel de significancia del 0,05.

Resultados: Como principales resultados, el 47,51% presentó el síndrome de burnout siendo el agotamiento emocional la dimensión de mayor prevalencia (77,83%), la alta autoestima se ubicó en el 58,82% de los informantes, mientras que la baja autoestima registró cerca de los 41 puntos porcentuales. La autoestima alta se relacionó con niveles bajos de agotamiento y falta de realización.

Conclusiones: Se concluye que, el aprecio que los trabajadores sienten a sí mismos disminuye la probabilidad de desarrollar agotamiento emocional y desrealización en 4,14 y 14,15 veces respectivamente. Por lo tanto, es importante tomar en cuenta el fomento de la autoestima laboral para prevenir los efectos nocivos provocados por los factores psicosociales de riesgo laboral.

Palabras clave: Autoestima, síndrome de agotamiento emocional, docentes universitarios, Maslash Burnout Inventory.

Abstract

Objective: The objective of the research was to determine how self-esteem prevents the appearance of depersonalization, emotional exhaustion, and lack of fulfillment in teachers of three higher technological institutes in the city of Quito, Ecuador.

Methods: Cross-sectional, observational, prospective, and analytical study, corresponding to the relational level. Two surveys were applied to a sample of 221 teachers, the first was the Maslash Burnout Inventory (MBI-Ed) to assess emotional exhaustion syndrome, and the self-esteem questionnaire "IGA-2000". The research hypothesis dictated the existence of a negative correlation between self-esteem and burnout. For the inferential analysis, Spearman's Chi-square test was used with a significance level of 0.05.

Results: As main results, 47.51% presented burnout syndrome, emotional exhaustion being the most prevalent dimension (77.83%), high self-esteem was found in 58.82% of the informants, while low self-esteem registered about 41 percentage points. High self-esteem was related to low levels of burnout and lack of fulfillment.

Conclusions: It is concluded that, the appreciation that workers feel for themselves decreases the probability of developing emotional exhaustion and derealization by 4.14 and 14.15 times respectively. Therefore, it is important to consider the promotion of self-esteem at work to prevent the harmful effects caused by psychosocial occupational risk factors.

Key words: Self-esteem, emotional exhaustion syndrome, university teachers, Maslash Burnout Inventory.

Introducción

Actualmente se cuenta con mucha información acerca de la génesis de los factores psicosociales de riesgo a la salud y su relación con una larga lista de padecimientos físicos y mentales. De hecho, organismos de prevención como la Organización Mundial del Trabajo (OIT), desde finales del siglo XX, alertan a los gobiernos sobre la gestión de estos agentes para una mitigación de los procesos estresantes.

Por ejemplo, se estima que el ausentismo y las bajas médicas que se relacionan con este mal, generan pérdidas cercanas a los 300 mil millones de dólares al año. Y en el aspecto de la salud, los estresores incrementan el riesgo de enfermedades cardíacas; alteraciones hormonales; trastornos del sueño; problemas digestivos; impotencia sexual; y muchos otros padecimientos que impiden la calidad de vida y el desarrollo integral del ser humano¹.

Debido a esto, la literatura científica desde 1990, enfoca todos los esfuerzos por describirlos, entenderlos y predecirlos con una perspectiva preventiva relativamente exitosa en la disminución de enfermedades. En las fuentes de consulta, cerca del 90% de los artículos que abordan la salud ocupacional, tienen un alcance curativo, preventivo y mitigador, puesto que, se enfocan en la detección de un problema, la prevención de enfermedades y el control de agentes contaminantes nocivos².

Esto significa que, la norma es investigar “lo que anda mal” en las organizaciones, las malas prácticas y las equivocaciones humanas, las condiciones y actos subestándares, y todo factor que presente una carga de percepción negativa. Por tal motivo, son pocos los estudios que abordan los aspectos positivos de la psicología laboral y en específico, los indicadores de la salud mental positiva del trabajo. La gestión de los factores psicosociales eugenésicos para fomentar la salud laboral debería ser un interés, inclusive superior, al de evaluar y controlar los agentes de riesgo³.

La salud mental positiva es un esquema interpretativo que concibe el bienestar integral del ser humano en función de diversas categorías. Una de ellas es la enfermedad y es el modelo dicotómico clásico para diferenciar a las personas sanas de las enfermas. Si un trabajador presenta los suficientes signos y síntomas de una enfermedad definida en el clasificador internacional CIE 11, se considerará como afectado con alguna patología. Con este mismo criterio, las personas no enfermas serían aquellas quienes no presentan los suficientes signos y síntomas para que puedan ser diagnosticados con alguna enfermedad⁴.

No obstante, la salud mental positiva propone que existen otros dos grupos, que son: los sanos y los

no sanos. En primera instancia, el modelo global de producción, demanda altas exigencias en los trabajadores en calidad y tiempo. Poco importa la opinión de los colaboradores y se estima que la persona modelo, es aquella que “se pone la camiseta de su institución”, no discute las órdenes y acata la cultura organizacional. Esto propicia la enajenación laboral, que es el proceso mediante el cual, las normas del sistema imposibilitan que el individuo desarrolle la innovación y la creatividad, que genere una opinión propia, y se conforme con actividades poco atractivas que no le generan aprendizaje⁵.

Por su parte, los factores eugenésicos son aquellos agentes psicosociales que disminuyen la probabilidad de enfermedades y accidentes laborales; así como fortalecen las competencias, habilidades, destrezas y características de personalidad. Además, están relacionados directamente con la satisfacción laboral, la calidad de vida del trabajo, la motivación y la productividad. La autoestima, por ejemplo, es un factor que determina la confianza y la seguridad de las acciones y decisiones de la vida personal y laboral⁶.

Es posible fortalecer la autoestima de la población trabajadora a través de procesos de capacitación para que las personas aprendan a valerse por sí mismas, y no necesariamente los contenidos deben versar sobre cuestiones del trabajo. Por ejemplo, en una empresa metalmeccánica que contaba con una población obrera de más de 40 años de alrededor 55 individuos, durante un mes reciben un curso práctico de redes sociales y mensajería instantánea para teléfonos inteligentes⁷.

Aparentemente se pensaría que un proceso de capacitación que no tiene nada que ver con el campo de trabajo sería una propuesta estéril. Pero al cabo de los seis meses siguientes, se observa un mayor compromiso laboral y productividad. Los empleadores apoyan el desarrollo de habilidades muy necesarias en la vida del trabajador, quienes logran dejar de depender de sus hijos y amigos para enviar archivos adjuntos, registrar contactos y manejar carpetas virtuales. Esta situación les permite generar autoconfianza, satisfacción y agradecimiento para con la institución⁸.

Hay cierta evidencia empírica que establece una relación directa entre los niveles altos de autoestima y la prevención del burnout, en especial con el agotamiento emocional y la falta de realización. Es un hecho que este daño a la salud proviene de una exposición crónica de estrés laboral especialmente en profesiones de contacto directo con clientes-usuarios como la medicina y la docencia. Este último campo, presenta carga de trabajo alta, baja grupalidad y poco sentido de equipo (grupalidad - compañerismos); lo que lo hace susceptible a la violencia psicológica, las críticas, acusaciones y quejas de la comunidad educativa.

Por lo aquí expuesto, el presente estudio tiene el objetivo de determinar cómo la autoestima previene la aparición de la despersonalización, agotamiento emocional y la falta de realización en docentes de tres institutos tecnológicos superiores de la ciudad de Quito, Ecuador.

Métodos

Fue un estudio transversal, observacional, prospectivo y analítico, correspondiente al nivel relacional.

Con base a la totalidad de la población docente de tres institutos: Instituto Universitario Sucre (163 docentes), Instituto Técnico Superior Yavirac (210 profesores), Instituto Tecnológico Central Técnico (150 docentes) se conformó un marco muestral de 523 docentes. Al calcularse el tamaño de la muestra a partir de un nivel de confianza de 97,5%, (valor Alfa o máximo error tipo I de 5% y valor $Z=1,96$), una prevalencia de 0.50 ($p=0,50$ y complemento $q=0,50$), así como una precisión de 0,05, se trabajó con una muestra de 221 sujetos.

Se incluyeron a todos los docentes con más de 6 meses de permanencia, a tiempo completo y que firmaron consentimiento informado. Se excluyeron al personal que al momento de elaborar las encuestas se encontraban ausentes por baja médica, vacaciones, permiso de lactancia, maternidad o proceso de desvinculación. Se consideró eliminar a los participantes que remitieran encuestas incompletas, lo cual no ocurrió en la práctica.

Se utilizó la técnica de muestreo probabilístico aleatorio estratificado y para establecer el número de selección en cada una de las tres casas de educación superior, se multiplicó por el coeficiente de estratificación. De manera aleatoria con base a la fórmula aleatorio () del programa estadístico Microsoft Excel, se seleccionaron 69 sujetos del Instituto Sucre, 89 de Yavirac y 63 del Central Técnico.

En referencia a los instrumentos, se aplicó el cuestionario de autoestima de González (2001) validado para población adulta. El mismo cuenta con 25 reactivos con escala de Likert de tres respuestas: siempre (1), a veces (2), nunca (3). El índice de fiabilidad se ubica en 0,80. Existen 16 reactivos positivos (mayor puntaje, mayor autoestima) que son: 1, 7, 13, 19, 23, 2, 8, 14, 20, 24, 4, 10, 16, 22, 11, 17. Por otro lado, los reactivos negativos son los siguientes: 3, 9, 15, 21, 25, 5, 6, 12, 18. En tal sentido, el valor más alto que se puede alcanzar en autoestima alta es 16. Mientras que, el valor más bajo lo constituye los 27 puntos. Por lo anteriormente mencionado, las respuestas finales se presentan en función a los criterios de: alta autoestima o baja autoestima.

Por otro lado, el inventario burnout de Maslash utilizado fue el MBI-Ed estandarizado para profesionales del área de la educación. Cuenta con 22 ítems en escala

de Likert y presenta tres subdimensiones: el cansancio emocional o agotamiento se define como la fatiga, debilidad y extenuación del docente ante su trabajo (1,2,3,6,8,13,14,16, 20); la despersonalización sondea las actitudes de aislamiento, frialdad afectiva y cinismo hacia los compañeros y estudiantes (5,10,11,15,22); y la autoeficacia es la autovaloración que el docente tiene sobre su trabajo y la valía en sí mismo (4,7,9,12,17,18,19,21).

Para la calificación del instrumento, los investigadores acudieron a los baremos en donde se pueden observar tres grados de calificación: puntuaciones altas, medias y bajas. Por convencionalismo y con base a una gran diversidad de estudios se asumió que, los individuos que al menos hayan obtenido puntuaciones medias o altas en más de una dimensión son positivos para el síndrome. Con los dos instrumentos, a cada uno de los participantes se les adjuntó un listado de preguntas socio demográficas sobre el género, la edad, el tiempo de servicio y la escolaridad.

Para el análisis estadístico, se calcularon las frecuencias y porcentajes de las variables nominales (sociodemográficas) y de los puntajes de la autoestima y del burnout. La comprobación inferencial se basó en la prueba Chi cuadrado de Pearson con un nivel de significación del 0,05. Adicionalmente se utilizó el estadístico Gamma para estimar la fuerza y dirección inferencial. Las hipótesis de investigación fueron las siguientes:

- H1: las personas con alta autoestima presentarán bajos indicadores de burnout (despersonalización, agotamiento y auto realización) (correlación negativa).
- HA: Las personas con alta autoestima presentarán altos indicadores de burnout (despersonalización, agotamiento y auto realización) (correlación positiva).
- H0: No existe relación estadísticamente significativa entre autoestima y burnout.

Se calculó, además, la Odds ratio para conocer la probabilidad de ocurrencia entre autoestima y burnout.

Cada participante, conoció de los alcances y naturaleza del estudio a través del consentimiento informado. En todo momento se manejó la confidencialidad de los docentes. Los resultados fueron puestos en conocimiento de las autoridades para la elaboración de planes de mitigación psicosocial que propendan el mejoramiento de la calidad de vida de los trabajadores.

Resultados

En la **tabla I** se exponen los resultados de las variables de caracterización de la población de estudio. En la misma

se aprecia que existe un porcentaje bastante similar en función del género de los participantes, con una diferencia del 9,5% los hombres presentaron la mayor frecuencia. Los casados y solteros sumaron entre sí el 91,86% de la población. El 69,23% de los informantes ya contaban con títulos de posgrado que es la condición de contratación para la docencia universitaria. No obstante, el 25,24% se encontraba terminando sus estudios de postgrado. El 73,31% tuvo una edad comprendida entre los 30 y 40 años. Conforme al tiempo de servicio, el 91,85% ostentaba una permanencia superior al año de labores en los institutos superiores.

En la **tabla II** se muestran los resultados de la prueba de autoestima, en la que se observa que un poco más de la mitad de los participantes presentaron alto aprecio hacia sus características de personalidad y su carácter. Su definición como trabajador es muy buena y perciben que la contribución que diariamente realizan en la institución educativa es muy significativa. Por su parte, el 41,18% manifiestan sentimientos contrarios. Admiten la situación adversa como incontrolable y sucumben ante pensamientos negativos que descalifican su accionar y su valía como personas y como empleados.

En la **tabla III** se evidencian los resultados de la prueba de burnout, en la que se evidencia que si se suman en las tres dimensiones del burnout las puntuaciones altas y medias (personas expuestas) se obtiene lo siguiente: 77,83% de la población se encontró afectada por el cansancio emocional. Son comunes en este sentido la sintomatología de fatiga, agotamiento, debilidad y extenuación por las exigencias laborales. Simultáneamente se encontró la despersonalización con el 52,49% de presencia, porcentaje que manifestó sentimientos de aislamiento y de falta de empatía con el trabajo y los colaboradores.

Por otro lado, la desrealización personal afectó al 48,87% de informantes, quienes manifiestan percepciones negativas de su performance laboral. Además, el 47,51% presentó indicadores altos y medios en más de una dimensión del síndrome y por tal razón, sufren de burnout.

En la **tabla IV** se expone el resultado del análisis inferencial relacionado con la comprobación de hipótesis. Se aprecia que las personas que registraron puntuaciones bajas en cansancio emocional y desrealización registraron autoestima alta. Por ejemplo, únicamente 4 personas que tuvieron bajo cansancio emocional presentaron baja autoestima, y solo 1 de los 112 sujetos con baja desrealización, obtuvo la misma puntuación.

Esto explica que, al realizar el análisis inferencial se encontró una significación asintótica bilateral menor al 0,05 en la prueba Chi cuadrado y un valor Gamma

con signo negativo y superior al 0,60. Estos datos confirman la hipótesis de investigación en dos de las tres dimensiones del burnout: las personas con alta autoestima presentan bajos indicadores de agotamiento emocional y desrealización (correlación negativa). Así también se evidenció que la autoestima no tiene efecto sobre la despersonalización. Esta relación inferencial es más evidente en el análisis de asociación, puesto que, la alta autoestima impidió hasta en 4,14 veces la probabilidad de generar agotamiento emocional; y disminuyó hasta en 14,15 veces la probabilidad de desarrollar sentimientos de ineficacia personal.

Tabla I: Resultados socio demográficos.

Género	Docentes (n=221)	%
Femenino	100	45,25%
Masculino	121	54,75%
Estado civil		
Casado/a	103	46,61%
Soltero/a	100	45,25%
Divorciado/a	15	6,79%
Unión libre	3	1,36%
Escolaridad		
Doctorado PhD.	12	5,43%
Cuarto Nivel	153	69,23%
Tercer Nivel	56	25,34%
Edad (en años)		
21 - 30	56	25,34%
31 - 40	91	41,18%
41 - 50	71	32,13%
51+	3	1,36%
Tiempo de servicio		
De 0 a 1 año	18	8,14%
De 2 a 3 años	82	37,10%
Más de 3 años	121	54,75%

Tabla II: Resultados del cuestionario de Autoestima.

Autoestima	Docentes (n=221)	%
Autoestima alta	130	58,82%
Autoestima baja	91	41,18%

Tabla III: Resultados descriptivos del burnout.

Dimensiones	Alto	Medio	Bajo
EE Cansancio emocional	112 (50,68%)	60 (27,15%)	49 (22,17%)
PA Desrealización personal	60 (27,15%)	48 (21,72%)	113 (51,13%)
D Despersonalización	52 (23,53%)	64 (28,96%)	105 (47,51%)
Diagnóstico del Burnout	Presentan 105 (47,51%)		No presentan 116 (52,49%)

Tabla IV: Análisis inferencial para la comprobación de hipótesis.

DIMENSIONES	Agotamiento emocional	Desrealización	Despersonalización
Autoestima	$p= 0,001$ $\text{Gamma} = -0,81$ $\text{OR}= 4,14 \text{ IC}= 1,51 - 14,04$	$p= 0,000$ $\text{Gamma} = -0,61$ $\text{OR}= 14,15 \text{ IC}= 1,07 - 21,11$	$p= 0,501$

Discusión

La gran parte de la literatura científica se enfoca en describir los efectos negativos de los factores psicosociales de riesgo laboral y su efecto en la salud

de los trabajadores. La mayoría de estos abordajes se realizan sobre el síndrome de agotamiento emocional. En las investigaciones de Lovo (2020)⁹, se explica el incremento en las profesiones de primera asistencia del agotamiento emocional a partir de la tensión que se genera por la COVID-19. En términos promedios, durante la pandemia COVID-19, los registros del Maslach Burnout Inventory HSS se ubican en el 65%, valor cercano al que se obtiene en el diagnóstico del agotamiento de la presente investigación, lo cual permite comprender que, el nerviosismo y la angustia se mantienen en casi los mismos indicadores sobre todo en el sector de la educación universitaria. Tabares (2020)⁸, por ejemplo, indica que la adopción de la teleeducación significa desgaste emocional para el personal docente.

El hecho de aprender en poco tiempo los programas de educación en línea con los mismos indicadores de solvencia y calidad, afectan mentalmente a los profesores desde el bachillerato hasta la docencia universitaria. Más allá de estos esfuerzos investigativos, en el abordaje científico de Freire (2022)⁹, se analiza que, a pesar de estar cercanos a que se levante la declaratoria de emergencia por parte de la Organización Mundial de la Salud (OMS), los docentes continúan con un régimen laboral híbrido, en donde acuden presencialmente a su lugar de trabajo para desde allí conectarse on line en clases virtuales con sus estudiantes.

Es decir, las altas exigencias originadas desde la implementación de los planes de emergencia dispuestos en pandemia no cesan, sino que se incrementan y ya son parte de la oferta académica de muchas carreras universitarias. No es raro, entonces, que el nivel de agotamiento, angustia, estrés y tensión se mantengan en constante crecimiento.

Los registros que se encuentran en el resto de las dimensiones de burnout están dentro de los parámetros que se consultan en estudios correlacionales del síndrome. Ejemplo de estas elaboraciones se encuentran en el análisis entre satisfacción, compromiso y agotamiento de Treviño (2022)¹⁰, en un metaanálisis de la génesis del burnout durante la pandemia que realiza Molero (2022)¹¹ y en la revisión teórica de un conjunto de poblaciones docentes que efectúa Meza (2022)¹². En todos ellos, la despersonalización alcanza hasta la tercera parte de las respectivas muestras, y la desrealización es el factor que mejor se registra.

Estos datos se relacionan con los que se presentan en las tablas descriptivas lo que ratifica la tendencia mundial que actualmente experimenta el síndrome de agotamiento emocional en trabajadores asistenciales y docentes.

Al analizar estudios similares que se realizan desde la perspectiva de los factores eugenésicos, se encuentran

importantes abordajes como el que realiza Martínez-Mejía (2022)¹³, en el cual categoriza al desarrollo de la autoestima como una herramienta vital para prevenir el estrés crónico. De acuerdo con el autor, la alta estima de los trabajadores y la confianza en sí mismos, influye para la adopción de estilos de afrontamiento efectivos contra el estrés, en concordancia con la teoría de Lazarus y Folkman (1998).

La evidencia empírica en este punto es un tanto escasa y realmente no se cuenta con un esquema teórico suficiente para explicar y pronosticar los beneficios de desarrollar los indicadores de la salud mental positiva (especialmente post pandemia) en programas de mitigación psicosocial. Por ende, esta investigación es un paso en firme en el desarrollo de la construcción de las teorías positivas en el trabajo y en la acción eugenésica de la autoestima para prevenir padecimientos psicosociales que comprometen la economía, la productividad, la salud y calidad de vida de cientos de miles de trabajadores al año.

Conclusiones

El desarrollo de la autoestima resultó ser eficaz para disminuir la probabilidad de que los docentes generen cansancio, debilidad y fatiga, así como sentimientos negativos acerca de su valía como persona y trabajador. No se vieron afectaciones con la dimensión de la despersonalización por lo que los factores que la influyen deberán ser investigadas en ulteriores abordajes científicos.

Bajo la luz de los hallazgos de la investigación, si los departamentos de seguridad y salud ocupacional promocionaran el fortalecimiento de la autoestima en su personal, reducirían notablemente las probabilidades de agotamiento emocional y desrealización en el trabajo. Con el desarrollo de este indicador eugenésico, no se intenta desviar la responsabilidad que tienen los empleadores de adecuar los puestos de trabajo, controlar los contaminantes y dotar de las mejores condiciones de confort a su personal. Sino que, se fortalecen los principios de auto protección, puesto que la autoestima es un rasgo esencial que le permite al trabajador vivir en plenitud consigo mismo y con su medio circundante.

Como se ha revisado, el trabajar en retribuir el amor propio y la dignidad de los trabajadores es un proceso de ganar – ganar. La empresa contará con una persona comprometida, feliz y orgullosa de laborar en una institución que se preocupa por sus colaboradores, por lo que los índices de productividad y excelencia en el servicio y producto serán proporcionales con el grado de satisfacción.

Si se quieren centros de trabajo eugenésicos, es necesario promocionar la salud mental positiva en

el trabajo, disminuir la enajenación y alienación que sufren los trabajadores al no poder desarrollar sus competencias de innovación y creatividad. Finalmente, debería ser un anhelo permanente de las ciencias de la salud y seguridad en el trabajo, el convertir en centros de formación continua a cada empresa productiva tal como lo recomienda la OIT.

Conflicto de intereses

Los autores declaran no tener ningún conflicto de intereses.

Referencias bibliográficas

1. Loli Pineda, AE, Danielli J, Navarro V, Cerón F, Del Carpio J, Vergara A. Calidad de vida laboral, autoestima y desempeño en el trabajo de los profesionales de la administración pública y privada en el Perú. *Revista Interamericana de Psicología Ocupacional*. 2020; 39(1): 27-40.
2. Gutiérrez ZJH, Miranda VT, Taípe PCO. Autoestima y desempeño laboral de las enfermeras del Hospital Daniel Alcides Carrión-Callao. *Pesquimat*. 2020; 23(2): 19-33.
3. Castro LK, García CH, Estrada R EL. Exclusión social, inclusión política y autoestima de jóvenes en pobreza, Monterrey, México. *Revista de ciencias sociales*. 2020; 26(1): 38-50.
4. Contreras-Camarena C, Lira-Veliz H, Benito-Condor B. Autoestima y síndrome de burnout en médicos de unidades críticas. Estudio correlacional. Hospital Nacional Dos de Mayo. Lima-Perú. *Horizonte Médico*. 2021; 21(2).
5. Trujano RS, Briseño RAE, Mata SM. Autoestima en parejas heterosexuales en la etapa de hijos pequeños. *Revista Electrónica de Psicología Iztacala*. 2020; 23(1): 180-98.
6. Benavides Mora VK, Palacios Díaz AJ, Zambrano Guerrero CA. Relación entre el Burnout Académico y la Autoestima, en estudiantes de pregrado de Medicina. 2020; 20(1): 19-31. doi:10.18566/infpsic.v20n1a02
7. Lovo J. Síndrome de burnout: Un problema moderno. Entorno [Internet]. 30 de diciembre de 2020 [citado 30 de septiembre de 2022];(70):110-2. Disponible en: <https://www.camjol.info/index.php/entorno/article/view/10371>
8. Tabares-Díaz Y, Martínez-Daza V, Matabanchoy-Tulcán S. Síndrome de Burnout en docentes de Latinoamérica: Una revisión sistemática. *US [Internet]*. 31ago.2020 [citado 30sep.2022];22(3):265-79. Disponible en: <https://revistas.udenar.edu.co/index.php/usalud/article/view/4458>
9. Freire C, del Mar Ferradás M, García-Bértoa A, Núñez JC, Valle A. Perfiles docentes basados en su sintomatología de burnout: diferencias entre etapas educativas y relación con el funcionamiento psicológico adaptativo. *Revista de Psicodidáctica*. 2022. doi:10.1016/j.psicod.2022.07.001
10. Treviño-Reyes R, López-Pérez JF. Factores críticos en la satisfacción laboral, el compromiso organizacional y el agotamiento laboral (burnout) en docentes de México. *Información tecnológica*. 2022; 33(2): 259-68.
11. Molero PP, Valero GG, Ibáñez EM, Janer MV, Caballero MO, Jiménez JLU. Evolución de la producción científica del síndrome de burnout, inteligencia emocional y práctica de actividad físico-saludable en docentes. *Revista INFAD de Psicología. International Journal of Developmental and Educational Psychology*. 2022; 2(1): 359-68.
12. Meza MDRS, Meza CES, Vergaray JM. Síndrome de Burnout en el profesional docente en el marco de la Covid-19. *Revisión Teórica. Revista Científica Arbitrada Multidisciplinaria PENTACIENCIAS*. 2022; 4(2): 31-46.
13. Martínez-Mejía E. Espectro de los factores psicosociales en el trabajo: Progresión desde los riesgos psicosociales hasta los protectores psicosociales. *CIENCIA ergo-sum*. 2022; 30(2).

ORIGINAL

Exploring biomedical waste management and disposal practices among hospitals in Port Harcourt, Rivers State

Exploración de las prácticas de gestión y eliminación de residuos biomédicos en los hospitales de Port Harcourt, Estado de Rivers

David Chinaecherem Innocent¹ , Cosmas Nnadozie Ezejindu², Stanley Chinedu Eneh³ , Angelica Chinecherem Uwaezuoke⁴ , Valentine Nnachetam Unegbu⁵, Advait Vasavada⁶ 

1. Department of Public Health, Federal University of Technology Owerri, Imo State Nigeria

2. Department of Public Health, Abia State University, Uturu, Abia State, Nigeria

3. Department of Community Health, Obafemi Awolowo University, Ile-Ife, Osun State, Nigeria

4. Department of Medicine and Surgery, University of Nigeria, Nsukka, Enugu State, Nigeria

5. Department of Biological Sciences, Spiritan University Nneochi, Abia State, Nigeria

6. MP Shah Medical College, Jamnagar, India

Corresponding author

David Chinaecherem Innocent
E-mail: innocentdc1@gmail.com

Received: 4 - I - 2023

Accepted: 3 - II - 2023

doi: 10.3306/AJHS.2023.38.03.79

Abstract

Background: Globally, disposal of biomedical waste is an environmental concern, as most medical wastes are infectious and could potentially lead to the spread of infectious diseases. The aim of this study was to assess the biomedical waste management and disposal practices among hospitals in Port Harcourt, Rivers state.

Method: A hospital based cross sectional design was adopted for this study on the biomedical waste management and disposal practices among hospitals in Port Harcourt, Rivers state. Statistical package for Social Sciences (SPSS) version 22.0 was used for the analysis of the study and chi square to determine association between variables ($P=0.05$). A structured questionnaire was used for data collection and a stratified and simple random sampling technique was used to draw out a total of 202 respondents who participated for the study.

Results: The study revealed that 35% (70) of the respondents were between 35-44 years of age. Overall knowledge of biomedical waste management among the health workers was 80.2%. From the study, Age ($p=0.00923$), Level of Education ($p=0.0025$) and Length of experience ($p=0.0457$) were all associated with the level of knowledge of biomedical waste management.

Conclusion: A significant number of hospital workers are aware of biomedical waste generation, management and disposal practices. Although, attitude to biomedical waste management and disposal practices among health workers is average therefore a challenge. Sensitization of hospital staff by the public health personnel to improve biological waste disposal among the inexperienced is recommended. Also the government and policy makers should design laws that would facilitate the reduction and susceptibility of improper hospital waste disposal.

Key words: Waste Management, Biomedical waste, Knowledge, Attitude, Waste Disposal, Hospitals.

Resumen

Antecedentes: En todo el mundo, la eliminación de los desechos biomédicos es una preocupación ambiental, ya que la mayoría de los desechos médicos son infecciosos y podrían conducir a la propagación de enfermedades infecciosas. El objetivo de este estudio era evaluar las prácticas de gestión y eliminación de residuos biomédicos en los hospitales de Port Harcourt, estado de Rivers.

Método: Se realizó un diseño transversal sobre las prácticas de gestión y eliminación de residuos biomédicos en los hospitales de Port Harcourt, estado de Rivers. Se utilizó el paquete estadístico para las ciencias sociales (SPSS) versión 22.0 para el análisis del estudio y el chi cuadrado para determinar la asociación entre las variables ($P=0.05$). Se utilizó un cuestionario estructurado para la recogida de datos y una técnica de muestreo aleatorio estratificado y simple para extraer un total de 202 encuestados que participaron en el estudio.

Resultados: El estudio reveló que el 35% (70) de los encuestados tenía entre 35 y 44 años de edad. El conocimiento general de la gestión de residuos biomédicos entre los trabajadores sanitarios era del 80,2%. Del estudio se desprende que la edad ($p=0,00923$), el nivel de estudios ($p=0,0025$) y la antigüedad ($p=0,0457$) están asociados al nivel de conocimientos sobre la gestión de residuos biomédicos.

Conclusiones: Un número significativo de trabajadores hospitalarios conoce las prácticas de generación, gestión y eliminación de residuos biomédicos. Sin embargo, la actitud hacia las prácticas de gestión y eliminación de residuos biomédicos entre los trabajadores sanitarios es media, por lo que constituye un reto. Se recomienda la sensibilización del personal hospitalario por parte del personal de salud pública para mejorar la eliminación de residuos biológicos entre los inexpertos. Asimismo, el gobierno y los responsables políticos deberían diseñar leyes que faciliten la reducción y la susceptibilidad de la eliminación inadecuada de residuos hospitalarios.

Palabras clave: Gestión de residuos, residuos biomédicos, conocimientos, actitud, eliminación de residuos, hospitales.

Introduction

Biomedical waste or hospital waste is any kind of waste containing infectious (or potentially infectious) materials¹. It may also include waste associated with the generation of biomedical waste that visually appears to be of laboratory or medical origin (example unused bandages, packaging, infusion kits), also research laboratory waste containing organisms or biomolecules that are mainly restricted from environmental release¹. Biomedical waste is a type of biowaste and they may also be called medical or clinical waste. Biomedical waste is spawned from medical and biological sources and activities such as the diagnosis, prevention or treatment of diseases. Common producers of biomedical waste include hospitals, health clinics, nursing homes, and medical research laboratories, dentists, and emergency medical services, offices of physicians, veterinarians, morgues or funeral homes. Biomedical waste can be solid or liquid².

Biomedical waste management involves activities from generation of waste to final disposal. It includes those measures taken in the generation, characterization, quantification, storage, handling, collection, transportation, and disposal of wastes¹. Biomedical waste is separate from normal trash or general waste and differs from other type of hazardous waste such as chemical, industrial and radioactive waste. It has become a major public health concern globally due to the potential of poorly managed hospital waste to cause disease and injury. The sustainable management of hospital waste has continued to generate increasing public health interest due to the health problems associated with exposure of human beings to potentially hazardous wastes arising from healthcare³.

In Nigeria, hospital waste is divided into two different groups which include infectious and non-infectious wastes. Infectious wastes include unwanted microbiological cultures and stock of infectious agents, pathological waste, waste from surgery or autopsy that were in contact with infectious agents, sharps (which includes potentially contaminated used and unused discarded needles, syringes, scalpels, lancets and other devices that can penetrate the skin), waste from human blood and products of blood, laboratory waste and other medical supplies that may have come in contact with blood or body fluids⁴. The non-infectious wastes includes general hospital wastes generated in the course of administrative and housekeeping functions of hospital establishments; and hence are comparable to the usual domestic waste.

Presently, considerable gap exist with regard to the assessment of hospital waste disposal practices in line with the hospital waste management and disposal plan particularly in Nigeria and in other countries in Sub-Saharan Africa. The need to absorb the processes prescribed in the hospital waste management and disposal plan becomes a necessity in view of the promiscuous dumping of hospital

waste in the metropolitan city of Port Harcourt, Rivers State, Nigeria. The nature and quantity of hospital waste generated as well as institutional practices with regards to sustainable methods of hospital waste management and disposal, including waste segregation and waste recycling are often poorly examined and documented. This is seen in several countries of the world including Nigeria, despite the health risks posed by the improper handling of hospital waste⁵. However, about 10-25% of hospital wastes is hazardous, and can create variety of health risks if not properly managed and disposed.

WHO estimates that over 20 million infections of hepatitis B, hepatitis C and HIV occur yearly due to unsafe sharp disposal following the re-use of syringes and needles without sterilization⁶, while the indiscriminate dumping of other hospital wastes can lead to ground and surface water contamination, and even cancer⁷. Other health problems associated with improper collection, treatment and disposal of hospital wastes include cholera, skin diseases, typhoid fever, malaria and gastroenteritis⁸. Indiscriminate burning and incineration of hospital waste have been linked to serious public health threat and pollution resulting in the release of toxic dioxin, mercury and many other toxic substances. These substances produce remarkable variety of adverse effects in humans even at extremely low doses⁹. Putrefaction occurs in portions of open refuse dumps, which have not been fully burnt and add to air pollution through foul smells and release of greenhouse gases. Sanitary landfill of hospital waste can lead to pollution of ground water if not properly managed. These make the safe waste disposal of biomedical wastes a necessity, a fact that has been emphasized in various international conventions including Agenda 21, adopted in 1992 at United Nations Conference on the Environment and Development (UNCED) which recommends the prevention and minimization of waste production, the reuse or recycling of waste to the extent possible, and the treatment of waste by safe and environmentally sound methods¹⁰. It is also of serious concern that the level of awareness and practice, particularly of health workers regarding biomedical or hospital waste management and disposal plan has not been adequately documented. WHO Program activities include developing technical guidance materials for assessing the quantities and types of waste produced in different facilities, creating national action plans, developing national healthcare waste management and disposal guidelines and building capacity at national level to enhance the way biomedical waste is dealt with in low-income countries¹¹. Classification of hospital wastes shows that of the total amount of waste generated by hospital activities, about 80% is general waste. The remaining 20% is considered hazardous material that may be infectious, toxic or radioactive. Every year an estimated 16,000 million injections are administered worldwide⁶, but not all of the needles and syringes are properly disposed of afterwards.

Biomedical waste contains potentially harmful microorganisms which can infect hospital patients, hospital workers and the general public. Hospital activities protect and restore health and save lives and reverse should not be the case in the various hospitals across the country. Disposal of biomedical waste is an environmental concern, as most medical wastes are infectious and could potentially lead to the spread of infectious diseases. Daily exposure to biomedical wastes leads to accumulation of harmful microorganisms in the body of exposed persons⁸. Improper disposal of hospital waste can have both direct and indirect health consequences on humans and the environment. Indirect consequences in form of toxic emissions from inadequate burning of biomedical waste¹². In developing countries like Nigeria, where many hospitals are competing for limited resources, the management and disposal of hospital wastes has received less attention and the precedence it deserves. Some hospitals dispose their biomedical wastes to municipal dumpsites without pre-treatment, leading to an unhealthy and hazardous environment. When dumped into the sea, it discharges poisons into the waters and it would be consumed by the marine creatures, the toxins would inject into the food chain and finally reach humans who consume the sea foods. Human exposure to such toxins can stunt human growth development and also cause birth defects. This trend is currently being experienced in Port Harcourt, Nigeria even when every disposal site is required by law to have environmental pollution prevention and control measures. Hundreds of tons of biomedical wastes are deposited in open dumpsites at the hospitals and on the roadsides of Port Harcourt metropolis, untreated and nonhazardous solid wastes, which now pose health risks to health workers, cleaning staff, patients, visitors, waste collectors, disposal site staff, waste pickers, drug addicts that use the contaminated syringes and needles. The overall objective of this study was to assess the biomedical waste management and disposal practices among hospitals in Port Harcourt, Rivers state.

Methods

Study Design and Setting

A hospital based cross sectional survey research design was adopted for the study to assess the biomedical waste management and disposal practices among hospitals in Portharcourt, Rivers State Nigeria, from May, 2021 to October, 2021.

The study was carried out within the capital of Rivers state known as Portharcourt city. Portharcourt is located in the southern Nigeria (Niger Delta).

Study Population

The study population includes health workers of the hospitals in the group of doctors, nurses, pharmacists, staff of laboratory departments and waste handlers. The study population also included the public and private hospitals.

The hospitals in Port Harcourt is 253 in number and it comprises of one (1) Federal Government owned, one (1) State Government owned and 251 individually owned hospitals.

Sample Size and Sampling Methods

Sample size for comparison of two proportions was used to determine minimum number of staff to be interviewed from each hospital and a total sample size of 218 was obtained.

A stratified and simple random sampling technique was used to draw out the number of respondents from each hospital using a table of random numbers for the study. The health workers were stratified according to their professional groups: doctors, nurses, pharmacists and laboratory staff, which amounted to four categories of health workers and the waste handlers. Then selection of respondents was done using simple random sampling via a computer generated table of random numbers. There was a list of staff in each stratum in all of the selected hospitals. Then serial numbers was assigned to each staff in keeping with the order of the list. Using the computer generated table of random numbers, participants was selected daily from each stratum in proportion to sample size until the total sample size was reached for both public and private hospitals.

Note: The selected hospitals in Portharcourt for the study included: University of Portharcourt Teaching Hospital (Owned and managed by the Federal Government of Nigeria), Braithwaite Memorial Specialist Hospital (BMH) Portharcourt (Owned and managed by the Rivers State Government), Queens Clinic and Pamo Clinic Portharcourt (owned by Individuals and managed privately).

Instruments for Data Collection

A well-structured questionnaire for information gathering was used in this study. the questionnaire contained information on the socio-demographic characteristics of the respondents, information about the respondents knowledge on biomedical waste management and information on the attitude of the respondents towards biomedical waste management and disposal practices.

Validity and Reliability

The questionnaire for this study was subjected to face validity. The questionnaire was designed in a simple language to avoid ambiguity, misinterpretation or misunderstanding of the questions or statements.

The test-retest method was used to test the reliability of the questionnaire using 10% of the sample size. This exercise was necessary because it enhanced the collection of relevant data, which also reduced bias. The analyzed data was reliable and the significant association set at $p < 0.001$ with Fisher's Exact Test. A Cronbach coefficient of 0.88 was obtained for the study.

Method of Data Collection

The questionnaire was administered to the health workers of the hospitals in the category of doctors, nurses, pharmacists and staff of laboratory departments, and waste handlers. Field observation of biomedical waste generation rate and quantification in both public and private hospitals was also carried out. The data collection tool was adapted from the rapid assessment tool developed for sub-Saharan African countries by the World Health Organization and the secretariat of the Basel Convention of the United Nations Environmental Program (UNEP). This tool was a biomedical waste management inventory questionnaire that was used in assessment of biomedical waste disposal practices in hospital.

Method of Data Analysis

Data collected in this study were edited, coded and entered into the Statistical Product and Service Solutions (SPSS) version 22.0 and Microsoft Excel 2010. Table of frequencies and percentages were constructed. Chi-squared test and p-value less than 0.001 was used to show that there is a significant association between the hospital workers and the assessment of biomedical waste disposal practice in the selected hospitals.

Ethics

An approval was obtained from the research ethical committee of Public Health Department, School of Health Technology, Federal University of Technology Owerri alongside a letter of introduction issued from the administrative office before carrying out this research. The questionnaire was completed privately and anonymously (none of the respondents was identified by name at any point during data collection). Verbal informed consent was obtained from all the participants before being allowed to participate in this study.

Results

Socio demographic Factors of the respondents

From the **table I**, 35% (70) of the respondents were between 35-44 years of age, 23% (46) had respondents between 15-24 years, 19% (60) were aged 25-34 and just 13% (27) included respondents between ages 45-50. Majority of the respondents were of Igbo origin (58%), 17% (34) were Yoruba, 15% (13), Hausa, 5% (10) Fulani and 6% (11) of the respondents chose options not listed but label 'Others'. Considering education level, 44% (89) had attained the tertiary level of education, 38% (77) secondary, 13% (25) primary level of education and under 6% (10) had Informal education levels. When asked about their length of experience, 29% (58) replied "1-5 years", 28% (57) 6-10 years, 22% (45) said "11-15 years", 19% (38) had experience of 16-20 years and only 2% (4) had an experience of 21 years and above. Majority (71%) of the respondents accepted they were hospital staff, while 29% (59) replied "No". 61.5% (988) (n=143) affirmed they were public staff, while about 38.4% (55) chose 'Private'.

Contractors accounted for 74.1% (106) of the hospital staff while 25.8% (37) replied "No". On the positions of the respondents, 27% were Laboratory technicians, 28% (40) were Nurses, 26% (37) Pharmacists, and 11% (15) were Medical Doctors. (n=143). 8% (12) of the respondents were waste handlers.

Respondents Knowledge on Biomedical Waste Management and Disposal Practices

Revealed in **table II** is the knowledge of respondents on biomedical waste management and disposal practices. 83% (168) of the respondents accepted it was important to know about biomedical medical waste generation, its hazards and safe management, while 17% (34) did not accept. When they were asked if they thought it was good to put all types of hospital waste into one container, 55% (110) replied "No", 41% (82) said "Yes", 5% (10) replied "Maybe". On question concerning knowledge of color-coding segregation of biomedical wastes, 61% (124) replied "Yes", 33% (68) said "No", and about 5% (10) replied "Maybe". 77% (155) of the respondents demonstrated that they followed color-coding for biomedical waste, while 23% (47) denied. 65% (122) of the respondents also took precautionary measures in handling hospital wastes according to the colors of their containers, while 35% (70) did not. Additionally, 65% (131) believed Personal protective equipment (PPES) can be useful in handling hospital waste, while 35% (71) denied. 32% (65), (n=202), used PPEs such as Cover-alls, 22% (45) used Safety boots, 17% (33) used personal protective gear not listed but label 'Others', 15% (31) used Hand gloves while 14% (28) used safety goggles. 49% (65) (n=131) of the respondents always wore PPEs, 29% (38) rarely, and 22% (28) only wore PPEs occasionally. When asked concerning disposing needles in general waste containers, 67% (135), replied "No", while 33% (67) said "Yes". 46% (94), reported they re-capped the used needles before disposal, 44% (89) said "Not always", and 10% (19) replied "No". 61% (124) also discarded the used needles immediately, while 39% (78) did not. Concerning needle stick injuries, 83% (167) obliged it was a problem, while 17% (35) did not accept. 24% (49) reported to be victims of Needle stick injuries while 76% (153) had not experienced such accidents. Majority (72%), (n=49), of the Needle stick injury victims had experienced it about 1-5 times and 74% (36) of them filed a report. 62% (126) of the respondents demonstrated awareness of the consequences of needle-stick injuries, while 38% (78) denied. On disposal of hospital wastes in open places, 86% (174) denied, while a small 14% (28) accepted, the former said to have buried them (30%), Incinerate the waste (27%), Burn them (6%), land fill them (7%) and 29% (51) of the respondents opted for disposal methods not listed but label 'Others'. 65% (131) of the respondents demonstrated use of covered trucks for hospital waste disposal, while 35% (71) used open trucks. Majority of the respondents (92%, 185), also dumped hospital wastes in Municipal dumpsites, while under 8% (17) reported 'Rivers'. From **figure 1**, the respondent's good knowledge of biomedical waste was 80.2% and poor knowledge was 19.2%

Table I: Socio demographic Factors of the respondents.

Characteristics	Frequency (n=202)	Percentage (%)
Age		
15-24	46	23%
25-34	60	19%
35-44	70	35%
45-50	27	13%
Total	202	100
Ethnicity		
Igbo	118	58%
Hausa	13	15%
Yoruba	34	17%
Fulani	10	5%
Others	11	6%
Total	202	100
Educational level		
Informal education	10	5%
Primary	25	13%
Secondary	77	38%
Tertiary	89	44%
Total	202	100
Length of experience in years		
1-5 years	58	29%
6-10 years	57	28%
11-15 years	45	22%
16-20 years	38	19%
21 years and Above	4	2%
Total	202	100
Are you a Hospital Staff		
Yes	143	71%
No	59	29%
Total	202	100
Hospital category		
Public	88	61.5%
Private	55	38.4%
Total	143	100
Are you a contractor?		
Yes	106	74.1%
No	37	25.8%
Total	143	100
What is your position?		
Doctor	15	11%
Nurse	40	28%
Pharmacist	37	26%
Laboratory Technician	39	27%
Waste Handlers	12	8%
Total	143	100

Respondents Attitude on Biomedical Waste Management and Disposal Practices

Illustrated in **table III**, 83% (168) replied "Yes" when asked if biomedical wastes are hazardous, while 17% (34) replied "No". The respondents (n = 168) reported they handles such wastes carefully, 28% (48) replied "Like common waste", 32% (53) did not specify but opted to choose 'Others'. 52% (104) scored safe management of biomedical waste as Good, 35% (71) Poor, and 13% (27) Fair. When the respondents were asked if proper management of biomedical waste can be seen as a financial burden on the hospital management, 64% (129) replied "Yes" and 36% did not oblige. 26% (52) of the respondents confirmed proper management of biomedical waste be achieved in the hospital through Team work, 25% (50) opined "Public Health Awareness", 18% (38) chose individual efforts, 11% (22) accepted all options were necessary and 19% (39) rejected all

available options. 76% (150) of the respondents reported that safe management of biomedical waste disposal was an extra burden on the workers duties, and 58% (117) obliged containers should be labeled before filling with waste. Also 65% (130) of the respondents agreed that infectious waste should be sterilized from infections before disposal. The respondents were asked if they would voluntarily attend program that will enhance and upgrade their knowledge about biomedical waste, 87% (175) agreed, while 13% (27) did not accept.

Association between Socio demographic characteristics and Level of Knowledge of biomedical waste among health workers

Revealed in **table IV** are the results for the test of a statistically significant relationship between Socio-demographic characteristics and Level of knowledge of biomedical waste among health workers. There was a statistically significant relationship between Age and Level of knowledge of biomedical waste among health workers in the study population, $\chi^2 = 1.342$, $df=3$, $p= 0.00923$. We therefore reject the null hypothesis of no significant relationship between Age and Level of knowledge of biomedical waste among health workers in the study population. Considering the hypothesis between Level of Education of health workers and knowledge of biomedical waste among health workers among relevant population, there was a statistically significant relationship between them, $\chi^2 = 1.2348$, $df=3$, $p= 0.0025$, therefore we reject the null hypothesis of no significant relationship between Level of Education of health workers and knowledge of biomedical waste among health workers in the study population. Given the relationship between Length of experience in years and knowledge of biomedical waste in the study population, there was a statistically significant association; $\chi^2 = 3.432$, $df=3$, $p= 0.0457$, therefore we reject the null hypothesis of no significant association between Length of experience in years and knowledge of biomedical waste in the study population. On the hypothesis between Being a Hospital Staff and knowledge of biomedical waste among primal population, There was a statistically significant relationship between Being a Hospital Staff and knowledge of biomedical waste in the study population, $\chi^2 = 2.653$, $df=1$, $p= 0.00789$. We therefore reject the null hypothesis of no significant relationship between Being a Hospital Staff and knowledge of biomedical waste in the study population. There was no statistically significant relationship considering the hypothesis between being a contracted worker and knowledge of biomedical waste among relevant population. $\chi^2 = 5.235$, $df=1$, $p= 0.01934$, therefore we fail to reject the null hypothesis of no significant relationship between being a contracted worker and knowledge of biomedical wastes. Considering the association between position in the hospital and knowledge of biomedical wastes, there was a statistically significant relationship. $\chi^2 = 1.324$, $df=1$, $p= 0.00765$, Therefore we reject the null hypothesis of no significant association between position in the hospital and knowledge of biomedical wastes among relevant population.

Table II: Respondents Knowledge on Biomedical Waste Management and Disposal Practices.

Variables	Frequency (n=202)	Percentage (%)
Do you think it is important to know about biomedical medical waste generation, its hazards and safe management?		
Yes	168	83%
No	34	17%
Total	202	100
Do you think it is good to put all types of hospital waste into one container?		
Yes	82	41%
No	110	55%
Maybe	10	5%
Total	202	100
Do you know about colour-coding segregation of biomedical wastes?		
Yes	124	61%
No	68	33%
Maybe	10	5%
Total	202	100
Do you follow colour-coding for biomedical waste?		
Yes	155	77%
No	47	23%
Total	202	100
Do you take precaution in handling hospital wastes according to the colours of their containers?		
Yes	132	65%
No	70	35%
Total	202	100
Do you believe that personal protective equipments (PPEs) like gloves can beuseful in handling hospital wastes?		
Yes	131	65%
No	71	35%
Total	202	100
Do you wear Personal Protective Equipments?		
Hand Gloves	31	15%
Cover-alls	65	32%
Safety booth	45	22%
Safety goggle	28	14%
Others	33	17%
Total	202	100
If Yes, how often do you wear PPEs?		
Rarely	38	29%
Always	65	49%
Occasionally	28	22%
Total	131	100
Are needles supposed to be put into general waste containers?		
Yes	67	33%
No	135	67%
Total	202	100
Do you re-cap the used needle?		
Yes	94	46%
No	19	10%
Not always	89	44%
Total	202	100
Do you discard the needle Immediately?		
Yes	124	61%
No	78	39%
Total	202	100
Is needle-stick injury a concern?		
Yes	167	83%
No	35	17%
Total	202	100
Have you had needle stick injury in the past one year?		
Yes	49	24%
No	153	76%
Total	202	100
If Yes, how many times?		
1-5	39	72%
6-10	9	17%
Above 10	6	11%
Total	49	100
Did you fill an incident report?		
Yes	36	74%
No	13	26%
Total	49	100
Are you aware of the consequences of needle-stick injury?		
Yes	126	62%
No	76	38%
Total	202	100
Do you dispose hospital waste in open Places?		
Yes	28	14%
No	174	86%
Total	202	100
If No, What do you do with them?		
Burn Them	11	6%
Bury Them	52	30%
Incinerate Them	47	27%
Land fill Them	13	7%
Others	51	29%
Total	174	100
What kind of trucks do you use in disposal of hospital wastes?		
Covered Trucks	131	65%
Open Trucks	71	35%
Total	202	100
Where do you dump the hospital wastes?		
Municipal dumpsites	185	92%
Rivers	17	8%
Total	202	100

Table III: Respondents Attitude on Biomedical Waste Management and Disposal Practices.

Variable		Frequency (n=202)	Percentage (%)
Is biomedical waste a hazardous waste?	Yes	168	83%
	No	34	17%
	Total	202	100
If Yes, how do you handle such waste?	Carefully	67	40%
	Like common waste	48	28%
	Others specify	53	32%
	Total	168	100
How can you score safe management of biomedical waste? Poor	Good	104	52%
	71	35%	
	Fair	27	13%
	Total	202	100
Can proper management of biomedical waste be seen as a financial burden on the hospital management?	Yes	129	64%
	No	73	36%
	Total	202	100
How can proper management of biomedical waste be achieved in the hospital?	Individual Effort	38	19%
	Team Work	52	26%
	Public Health Awareness	50	25%
	All of the Above	22	11%
	None of the Above	39	19%
	Total	202	100
Is safe management of biomedical waste an extra burden on the workers duties?	Yes	150	76%
	No	52	24%
	Total	202	100
Do you think that labeling the container before filling it with waste is of any clinical concern?	Yes	117	58%
	No	85	42%
	Total	202	100
Do you think that infectious waste should be sterilized from infections before its disposal?	Yes	130	65%
	No	72	35%
	Total	202	100
Will you like to attend voluntarily programmes that will enhance and upgrade your knowledge about biomedical waste?	Yes	175	87%
	No	27	13%
	Total	202	100

Table IV: Association between Socio demographic characteristics and Level of Knowledge of biomedical waste among health workers.

Socio Demographics	Knowledge of Biomedical Wastes		X ²	P-value	Decision
	High (%)	Low (%)			
Age 15-24 25-34 35-44 45-50	16(40.0)	34(60.0)	1.342	0.00923	Sig.
	36 (60.0)	24(40.0)			
	40(57.1)	30(42.9)			
	25(92.5)	2(7.4)			
Educational level Informal education Primary Secondary Tertiary	3(30.0)	7(70.0)	1.2348	0.0025	Sig.
	14(56.0)	11(44.0)			
	47(61.0)	30(39.0)			
	59(66.2)	30(33.8)			
Length of experience in years 1-5 years 6-10 years 11-15 years 16-20 years 21 years and Above	27(46.5)	31(53.4)	3.432	0.0457	Sig.
	37(64.9)	20(35.1)			
	33(73.3)	12(26.7)			
	36(94.7)	2(52.6)			
	4(100)	0(0)			
Are you a Hospital Staff Yes No	73(51.0)	70(48.9)	2.653	0.00789	Sig.
	39(66.1)	20(33.8)			
Are you a contractor? Yes No	80(75.4)	26(24.5)	5.235	0.1934	Insig.
	30(81.0)	7(18.9)			
What is your position? Doctor Nurse Pharmacist Laboratory Technician Waste Handlers	10(66.6)	5(33.3)	1.324	0.00765	Sig.
	29(72.5)	11(27.5)			
	30(81.0)	7(18.9)			
	20(51.2)	19(48.7)			
	8(66.6)	4(33.3)			

Discussion

The objective of this study was to evaluate biomedical waste management and disposal practices in hospitals in Port Harcourt, Rivers State, Nigeria. Considering the socio-demographic characteristics, with regards to age, findings from the study showed that 35% of the respondents were within the age group 35-44 years, the age seen in this study, is in consistence with the statement by John *et al.*,¹⁴ that 34.5% of hospital workers fall within this age category. Further findings from this study showed that 58% of the respondents were of Igbo origin and Christians. This could be because the study was conducted in the Southern part of Nigeria and the hospitals surveyed were located in Port Harcourt, Rivers State which is a neighboring eastern state of the federation predominated by Igbo people. This is also in consistence with the study conducted by Brisbe and Ordinoha,¹⁰ this study revealed that majority of the respondents (71%) are hospital staff and 74.1% are contractors. This signifies that majority of the hospital staff is not permanent staff and probably have other clinics or hospitals they earn a living out of and hence attention to work might be divided. This connotes a consistence with a similar study conducted by Cheeseman & Townend¹² and in contrast with a statement made in a publication by Griault¹⁵.

The findings of the study considering the knowledge of the forms of biomedical waste management and disposal practices revealed that 83% of the respondents accepted it was important to know about biomedical medical waste generation, its hazards and safe management. This implies that health workers have significant knowledge of the importance of controlled generation and disposal of biomedical wastes. This corroborates a publication by Da Silva *et al.*,³ that 85.2% of health workers in hospitals have an awareness of biomedical disposal practices. Concerning knowledge of color-coding segregation of biomedical wastes, 61% affirmed. This could be due to the fact that color-coding segregation of waste is a standard practice and has been adopted by most health facilities. A study by Kevin & Oguamanam¹⁶ is in consistence with this finding. Further investigation into the finding of this study shows that majority (77%) of the respondents demonstrated that they followed color-coding for biomedical waste, as corroborated by a previous finding by Ferreira² that medical facilities are required to ensure biomedical wastes are color-coded for disposal. Several studies also support this finding^{17,3,18,19,2,15,20}. This study revealed that 35% of the respondents did not take precautionary measures in handling hospital wastes according to the colors of their containers. This could be due to lack of provision of relevant colors of containers for biomedical waste disposal by the health facilities. This goes in contrast to a statement made in a publication by Adogu, & Ubajaka²¹ that under 10% of hospital workers in a survey did not take precautions in handling hospital wastes according

to the colors of their containers. Some studies by Buregyega *et al.*,²² Caviar *et al.*,⁹ Chauhan *et al.*,⁷ disagree with this finding. Additionally, 65% of hospital workers believed Personal protective equipment (PPES) can be useful in handling hospital waste, and the most adopted PPES are the cover-alls (35%). This could be because the cover-all ensures limbs and trunk are fully protected from biomedical wastes. This is in consistence to a similar study conducted by Abitebul and Loft²³ on the adoption of cover-all by hospital workers (39%). 83% of the respondents obliged Needle stick injuries are common, while 76% had not experienced such accidents. This finding falls in line with a previous study by¹² that 81% of hospital workers demonstrated knowledge of needle stick injuries and that 74% in a survey conducted did not experience needle stick injuries. This is in contrast to a publication by²². On disposal of hospital wastes in open places, 86% denied. This implies stringent adherence to laws put in place to check the disposal of biomedical wastes. Numerous publications support this finding^{24,25,23,26}. 65% of the respondents illustrated use of covered trucks for hospital waste disposal which is in line with required standard procedure, also Majority of the respondents (92%) also dumped hospital wastes in Municipal dumpsites, advance findings from this study show that under 8% reported 'Rivers'. This could be due to nonavailability of designated dumpsites in proximity or no dumpsites at all provided by relevant bodies.

Considering the information attitude on biomedical waste management and disposal Practices among respondents, the study revealed that based on overall response from the participants that 83% affirmed biomedical wastes are hazardous. This falls in line with previous studies^{27,17,3}. 52% of the respondents scored safe management of biomedical waste as 'Good', while 64% think that proper management of biomedical waste can be seen as a financial burden on the hospital management. This could mean the hospitals lack adequate resources for proper management of biomedical wastes and is corroborated by a publication by Alagoz & Kocasoy²⁸. 76% of the respondents reported that safe management of biomedical waste disposal was an extra burden on the workers duties. The implication here could be that most hospitals are understaffed and hence workers have to engage in more tasks than they should perform. A previous study by Adetunji *et al.*,²⁹ explicitly explained the problems of under-staffing. Also 65% of the respondents agreed that infectious waste should be sterilized from infections before disposal. 87% of the respondents accepted to voluntarily attend programs that will enhance and upgrade their knowledge about biomedical waste, further check into this study revealed that 13% did not accept. This could be due to lack of motivation and poor attitude to work created as a result of untimely and underpaid monthly earnings. This is in consistence to several studies^{14,16,30,31}.

Findings from this study regarding the association between Socio demographic Characteristics and Level of knowledge of biomedical wastes revealed that Age is significantly associated with level of knowledge of biomedical wastes among health workers ($P=0.00923$). This implies that there was a significant increase in the level of knowledge of biomedical wastes as the age of the respondents under consideration increased. This could be due to the exposure that come with increased age, which could imply increase length in practice and is in line with studies by Da Silva *et al*,³ which found age to be associated with knowledge of biomedical wastes ($P=0.00861$). Moving further, the study also demonstrated that the level of education of health workers is significantly associated with the knowledge of biomedical waste ($P=0.0025$). This could be due to the fact that the higher the education level of the respondents the more likely they must have come across biomedical waste management and disposal practices. This goes in contrast with a report published by Abitebul & Loft,²³ that the education level of health workers may not affect the level of knowledge of biomedical wastes among primal population. Also, from the study among health workers in selected hospitals in Portharcourt, Rivers State, it was posited that length of experience in years shows significant association with level of knowledge of biomedical wastes ($P=0.0457$). Study shows that the level of knowledge of biomedical wastes was minimal among respondents who have practiced for 1-5 years, compared to health workers with 21 years and above practice experience. This is in consistence to studies conducted by Buregyega *et al*,²² Caviar *et al*,⁹ and Chauhan *et al*,⁷ but goes against a publication by Grioult¹⁵. The study revealed that level of knowledge of biomedical wastes was high among the waste handlers 66.6% compared to any other position among health workers in the Portharcourt hospitals and hence a significant relationship ($P=0.00765$). Studies according to Cheeseman & Townend¹² stated that health workers who are responsible for waste handling in hospitals had the highest knowledge of biomedical wastes and disposal practices. This level of knowledge could be due to the position of employment in these hospitals respectively.

Conclusion

Based on the outcomes of the study, it could be seen that a significant number of hospital workers are aware of biomedical waste generation, management and disposal practices. This includes the use of PPES and color-coding hospital wastes before disposal. However, the attitude to biomedical waste management and disposal practices is average and therefore a challenge. The study also reveals that medical facilities lack adequate resources needed to properly dispose of biomedical wastes. Strict laws to guide disposal of hospital waste which have been put in place need to be reinforced. Also Ease of biomedical wastes disposal by creating dumpsites at strategic points should be considered. Hospital staff/workers should also be sensitized, encouraged on the hazards of biomedical wastes and Importance of good waste management. Understaffed hospitals are required to hire workers with relevant qualifications to promote biomedical waste management and disposal.

Recommendations

Based on the finding of this study, it is recommended government and policy makers should design laws that would facilitate the reduction and susceptibility of improper hospital waste disposal. Also Provision of disposal facilities such as landfills sites and incinerators at strategic points to increase ease in disposition of biomedical wastes is imperative.

Ethics Approval and consent to Participate

Not Applicable

Consent to Publish

Not applicable

Availability of Data and Materials

The Data set from the study are available to the corresponding author upon request.

Competing Interests

Authors have declared that they have no competing interests

Funding

No funds were received for this study

Acknowledgements

Not Applicable

References

- Jenkin LE, Noonan CL, Tudor TL. Healthcare waste management: A case study from the Cornwall NHS, UK 2015; 25(3):606-15.
- Ferreira AP, Veiga MM. Hospital waste operational procedures: A case study in Brazil 2013; 21(4):377-82.
- Da Silva CE, Hoppe AE, Mello N, Ravello MM. Medical waste management in the south of Brazil 2015;25(2):600-5.
- Federal Environmental Protection Agency (FEPA). Guidelines and standard for industrial effluents, gaseous emission and hazardous waste management in Nigeria 2001; 20-5.
- Oke IA. Management of immunization solid wastes in Kano state, Nigeria. Waste Management 2018; 28(3):2512-21.
- Kane A, Kane M, Lloyd J, Simonsen L, Zaffran M. Transmission of hepatitis B, hepatitis C and human immunodeficiency viruses through unsafe injections in the developing world: Model-based regional estimates. Bulletin of the WHO 2009; 77(5): 801-7.
- Chauhan R, Jha PK, Kumar M, Ramanathan A, Singh UK, Subramanian V. Assessment of the impact of landfill on ground water quality : a case study of Pirana site in western India. Environmental monitoring assessment 2018; 141(15): 309-21.
- Chukwuezie CI. Microbiology of refuse dumps in Port Harcourt. University of Port Harcourt, M.Sc. 2008;Thesis;49.
- Caviar B, Colwell RR, Deming JW, Peele ER, Singleton FL. Effects of pharmaceutical waste on microbial populations in surface waters at the Puerto Rico dumpsite in Atlantic Ocean. Applied Environmental Microbiology 2008; 41(3):873-9.
- Brisbe S, Ordinoha B. The management of Healthcare waste in tertiary healthcare institution in Port Harcourt, South –South Nigeria. Journal of Community Medicine and Primary HealthCare 2019; 21(5): 37-44.
- Karademir A. Health Risk Assessment of emissions from a hazardous and medical waste incinerator in Turkey. Environmental International Journal 2014; 30(4):1027-38.
- Cheeseman CR, Townend WK. Guidelines for the evaluation and assessment of the sustainable use of resources and of wastes management at healthcare facilities 2015; 23(7):398-408.
- National Bureau of Statistics Nigeria. State information, Nigeria. 2013
- John SA, Ocheke N, Odumosu P, Ndidi N. Waste management in healthcare establishments within Jos Metropolis, Nigeria. Africa Journal of Environmental Science Technology 2019; 3(12): 459-65.
- Griault E, Pruss A, Rushbrook P. Safe management of wastes from healthcare activities. Geneva, WHO 2009; 17-20.
- Kevin CD, Oguamanam OE. Knowledge, perception and practice of injection safety and hospital waste management among Teaching hospital staff in south east Nigeria. The Nigeria Health Journal 2015; 12(1):4-9.
- Coker AO. Medical waste management in Ibadan, Nigeria: Obstacles and Prospects. Waste Management Journal 2009; 29(2): 804-11.
- Ekugo EI. Public Health and Urban Sanitation. Environmental News 2008; 5(2):7-8.
- Farzadika M, Mohammadi MS, Moradi A. Hospital Waste Management status in Iran: A case study in the teaching hospitals of Iran. University of Medical Sciences 2009; 27(4):384-9.
- Islam MR, Uddin MN, Yesmin K. Knowledge on hospital waste management among senior staff nurses working in a selected medical college hospital of Bangladesh. Journal of Waste Management 2014; 20(14):57-69.
- Adogu P, Ubajaka CF. Knowledge and practice of medical waste management among health workers in a Nigerian General Hospital. Asian Journal of Science and Technology 2014; 5(12):833-8.
- Buregyega E, Musinguzi G, Musoke D, Ndejo R, Wang JS, Yu X. Occupational health hazards among healthcare workers in Kampala, Uganda. Journal of Environmental Public Health 2015;20(15):9-13.
- Abitebul D, Loft F. Health Professionals infected with HIV in France. France Medical Bulletin 2013; 5(20):111-3.
- Abah SO, Ohimain EI. Assessment of Dumpsite Rehabilitation Potential using the Integrated Risk Based Approach: A case study of Eneka, Nigeria. World Applied Science 2010; 8(4):436-42.
- Abegunde AA, Adegbita MA, Afon A, Bamise CT, Nwafor SO. Assessment of dental waste management in a Nigerian tertiary hospital. African Medical Journal 2010; 5(2):21-32.
- Abdullah MK, Al-mukhtar S. Assessment of medical waste management in teaching hospitals in Mosul City. A descriptive study. Mosul Nursing Journal 2013;1(1):1-18.
- Chitnis DS, Chitnis V, Vaidya K. Biomedical waste in laboratory medicine: Audit and management. Indian Journal of Medical Microbiology 2018; 23(5):6-13.
- Alagoz BA, Kocasoy G. Treatment and disposal alternatives for health-care wastes in developing countries – A case study in Istanbul, Turkey 2017;25(4)83-9.
- Adetunji B, Chima G, Gidado S, Isichei C, Ogoina D, Pondei K. Prevalence and determinants of occupational exposures to blood and blood fluids among health workers in two tertiary hospitals in Nigeria. African Journal of Infectious Diseases 2014; 8(2):50-4.
- Ramesh K, Ratan S. Knowledge, attitude and practice of health staff regarding infectious waste handling of tertiary care HCF at metropolitan city of Pakistan. Journal of Ayub Medical College Abbottabd 2013; 25(1-2): 45-122.
- Wahab AB. Waste Disposal and Environmental Hazard Control, Lagos. West African Health Examination Board 2001;22-34.

Colistin Resistance in Clinical Isolates of *Acinetobacter baumannii* by Broth Microdilution Method, Biofilm Production, and Antimicrobial Susceptibility Profiles: Experimental Study

Resistencia a la colistina en aislados clínicos de Acinetobacter baumannii por el método de microdilución en caldo, producción de biopelículas y perfiles de susceptibilidad a los antimicrobianos: Estudio experimental

Anas M.J. Jamal Masalmeh¹ , Emrah Güler^{2,3,4} , Kaya Sürer⁵ , Meryem Güvenir⁶ 

1. Near East University, Faculty of Medicine, Department of Medical Microbiology and Clinical Microbiology, Nicosia, Cyprus

2. Near East University, Faculty of Health Sciences, Department of Nutrition and Dietetics/Microbiology, Nicosia, Cyprus

3. Near East University, DESAM Research Institute, Nicosia, Cyprus

4. University of Kyrenia, Faculty of Medicine, Department of Medical Microbiology and Clinical Microbiology, Kyrenia, Cyprus

5. Near East University, Faculty of Medicine, Department of Infectious Diseases and Clinical Microbiology, Nicosia, Cyprus

6. Cyprus Health and Social Sciences University, Faculty of Medicine, Department of Medical Microbiology, Güzelyurt, Cyprus

Corresponding author

Meryem Güvenir

E-mail: meryemguvenir@hotmail.com

Received: 7 - I - 2023

Accepted: 5 - II - 2023

doi: 10.3306/AJHS.2023.38.03.89

Abstract

Objective: Colistin susceptibility tests become more importance because of the need for colistin use increases especially treatment of the multidrug-resistant (MDR) bacterial infections. In addition, biofilm formation by microorganisms is an important cause of antibiotic resistance. The aim of this study was to evaluate the colistin susceptibility by broth microdilution (BMD) method, biofilm formation, and antibiotic resistance profiles in the *Acinetobacter baumannii* (*A. baumannii*) strains.

Materials and Methods: Fifty *A. baumannii* strains which were isolated from clinical specimen were included. Identification of the isolates were studied with the BD Phoenix100 automated system by using the Phoenix NMIC-400/ID panels. The antimicrobial susceptibility test for the colistin were studied by the Mueller-Hinton BMD method according to EUCAST. The biofilm production were investigated using Congo Red Agar.

Results: Of the 50 isolates, colistin resistance by BMD method was found 2% (n:1). The rates of biofilm formation and MDR were %92 (46/50) and %76 (38/50), respectively. It was determined that the biofilm formation rate increased in parallel with the age of the patients ($p=0.008$). Moreover, MDR positive strains were found to produce biofilms more frequently than negatives ($p=0.038$).

Conclusion: Unfortunately, our study is the first report for the colistin resistance in Northern Cyprus. Biofilm formation of *A. baumannii* strains examined in our study were found to be high. Therefore, we think that the application of correct diagnostic methods, full sterilization/disinfection procedures, and rational use of antibiotics may affect the morbidity and mortality rates, as they will prevent the development of MDR microorganisms.

Key words: *Acinetobacter baumannii*; colistin; biofilm; multi-drug resistance.

Resumen

Objetivo: Las pruebas de susceptibilidad a la colistina adquieren mayor importancia debido a que aumenta la necesidad de utilizar colistina, especialmente en el tratamiento de las infecciones bacterianas multiresistentes (MDR). Además, la formación de biopelículas por parte de los microorganismos es una causa importante de resistencia a los antibióticos. El objetivo de este estudio fue evaluar la susceptibilidad a la colistina por el método de microdilución en caldo (BMD), la formación de biofilms y los perfiles de resistencia a los antibióticos en las cepas de *Acinetobacter baumannii* (*A. baumannii*).

Materiales y métodos: Se incluyeron 50 cepas de *A. baumannii* aisladas de muestras clínicas. La identificación de los aislados se estudió con el sistema automatizado BD Phoenix100 utilizando los paneles Phoenix NMIC-400/ID. La prueba de susceptibilidad antimicrobiana para la colistina se estudió mediante el método Mueller-Hinton BMD según el EUCAST. La producción de biofilm se investigó mediante el uso de Agar Rojo Congo.

Resultados: De los 50 aislados, se encontró una resistencia a la colistina por el método BMD del 2% (n:1). Las tasas de formación de biofilm y de MDR fueron del 92% (46/50) y del 76% (38/50), respectivamente. Se determinó que la tasa de formación de biofilm aumentaba en paralelo a la edad de los pacientes ($p=0,008$). Además, se observó que las cepas MDR positivas producían biofilms con mayor frecuencia que las negativas ($p=0,038$).

Conclusiones: Lamentablemente, nuestro estudio es el primer informe sobre la resistencia a la colistina en el norte de Chipre. La formación de biopelículas de las cepas de *A. baumannii* examinadas en nuestro estudio resultó ser elevada. Por lo tanto, creemos que la aplicación de métodos de diagnóstico correctos, procedimientos de esterilización/desinfección completos y el uso racional de antibióticos pueden afectar a las tasas de morbilidad y mortalidad, ya que evitarán el desarrollo de microorganismos MDR.

Palabras clave: *Acinetobacter baumannii*; colistina; biofilm; multiresistencia.

Introduction

Colistin, an antibiotic of the polymyxin group, was synthesized in the 1940s and its use continued until the 1970s. Polymyxin B and Polymyxin E (colistin), which are about thirty different polymyxin compounds, have a similar structure and are used clinically¹. Polymyxin E, also known as colistin, weighs 1200 Da and it is synthesized by adding a hydrophobic fatty acid tail to the hydrophilic polycationic peptide chain². Due to its serious nephrotoxic and neurotoxic effects, the parenteral use of colistin has gradually decreased after the 1970s. Because of the development of resistance against aminoglycoside and carbapenem for the Gram-negative bacteria, clinicians led to the re-introduction into parenteral use of colistin in 2000s for treatment^{3,4}.

Especially, the prevalence of the multi-drug resistant (MDR) *Acinetobacter baumannii* (*A.baumannii*) is being increased, the need for colistin usage increased. Therefore, colistin susceptibility tests gained importance. In order to test the antimicrobial susceptibility of colistin in both *Acinetobacter* species and other resistant bacterial species, studies were using the disk diffusion, gradient test, agar dilution and broth microdilution methods⁵⁻⁷. The studies indicated that the disk diffusion and gradient test methods, which are preferred in routine microbiology laboratories due to their ease of use, are not reliable in testing the antimicrobial susceptibility of colistin, neither the CLSI (Clinical and Laboratory Standards Institute) nor the EUCAST (European Committee on Antimicrobial Susceptibility Testing) also not recommend these tests for antimicrobial susceptibility of colistin^{5,8,9}.

Biofilm formation by pathogenic microorganisms is an important reason for the development of antibiotic resistance. The main reason why *A. baumannii* strains can survive on medical instruments and are resistant to antibiotics is their ability to form biofilms on solid surfaces. *A. baumannii* strains that can form biofilms can escape from the immune mechanisms of the host and thus cause prolongation of infectivity. The omp A gene found in the bacteria is related to biofilm formation and is the most important virulence factor affecting the mortality rate in infections caused by *A. baumannii*^{10,11}.

Increasing resistance to antibiotics used in the treatment of *Acinetobacter spp.* infections continues to be a serious health problem. MDR *A. baumannii* strains are the bacteria responsible for hospital infections that create difficulties in the treatment of inpatients. It is of great importance to determine the risk factors for *Acinetobacter* infection and to take precautions against these risk factors due to the limited treatment options, the frequent outbreaks that are difficult to prevent, and the high mortality^{12,13}.

The aim of the study was to investigate the minimum inhibitory concentration (MIC) values of the colistin

by broth microdilution method for the *A. baumannii* clinical isolates of the Near East University Hospital, Microbiology laboratory. In addition, examining the biofilm formation and resistance profiles of the strains is one of our other goals.

Material and methods

Bacterial isolates

A total of 50 non-duplicate clinical isolates of *A. baumannii* isolates in Microbiology Laboratory of our hospital in 2020 were included in our study. Various specimens were collected from different sites including aspirate, bronchoalveolar lavage, and sputum. All samples were taken from inpatients. Patient data such as age, gender, hospital department and admission type were obtained from the hospital system and electronically stored. The clinical samples were cultured on eosin-methylene blue (EMB) agar and blood agar, and were incubated aerobically at 35°C for 24-48 hours. Repeating isolates from the patients were excluded from the study.

Identification and antimicrobial susceptibility testing

The identification of the isolates were performed by the BD Phoenix 100 (Becton Dickinson, USA) automated system using the Phoenix NMIC-400/ID panels, and the colistin-resistant MICs were confirmed by broth microdilution test, according to EUCAST (European Antimicrobial Susceptibility Testing Committee) recommendations⁹. Intermediate antibiotic susceptibility results were considered resistant. The susceptibility categories were interpreted according to break-points of EUCAST guidelines. Colistin MICs >2 µg/mL were considered resistant⁹. Strains resistant to all penicillin antibiotics, as well as at least three of the cephalosporin, quinolone, carbapenem, and fluoroquinolone antibiotic groups, were considered MDR¹⁴.

Biofilm formation

Modified Congo Red Agar (MCRA) consists of 0.4 grams of Congo red dye (Alfa Aesar, ThermoFisher GmbH, Erienbachweg 2, 768 70 Kandel, Germany), 10 grams of glucose (Merck, KgaA, Germany), and blood agar base (Merck, KgaA, Germany). The Congo red dye was prepared in 100 ml of distilled water and autoclave at 121°C for 15 minutes. The glucose and the blood agar were dissolved in 900 ml of distilled water and autoclave at 121°C for 15 minutes. The dye was combined with blood agar and glucose and thoroughly mixed until homogeneous before pouring into the sterile petri dishes. *A. baumannii* isolates were plated on MCRA and incubated aerobically at 35±2°C for 24 hours. The red-coloured colony's observation was considered as biofilm negative and black-coloured colony as positive. ATCC6538 *Staphylococcus aureus* strain was used as biofilm positive control in MCRA method.

Statistical analysis

Statistical analyses were performed using SPSS Demo Ver 22 (SPSS Inc., Chicago, IL, USA). Pearson chi-square or Fisher's exact tests measured the differences between two proportions. A one-way ANOVA test was used to determine the statistical differences in the groups' mean. A p-value <0.05 was accepted to be statistically significant.

Ethical approval

Ethics committee approval was obtained with the project number NEU/2021/95-1402 at the meeting held by the NEU Scientific Research Ethics Committee on 30.09.2021. In addition, the study was carried out in accordance with the principles of the Declaration of Helsinki.

Results

In our study, 50 patients hospitalized in our hospital in 2020 and *A. baumannii* isolated in any culture sample were included. Of these patients %74 (37/50) were male, %26 (13/50) were female, and their mean age was 65.16±15.44, 67.15±20.78 (general 65.68±16.78, between 24-91 years), respectively. There was no significant relationship between gender and the mean age of the patient (p=0.717).

Of the examined samples, 62% (31/50) were aspirate, 16% (8/50) were sputum, and 10% were (5/50) broncho alveolar lavage (BAL). Fifteen aspirate samples (48.4%) were isolated from the intensive care unit (ICU). According to the EUCAST guidelines for *A. baumannii* isolate sensitivity testing of colistin, we found 1 strain (2%) was resistant and 49 strains (98%) were sensitive.

The resistance rates given by the automated system to amikacin, ciprofloxacin, gentamicin, imipenem,

levofloxacin, meropenem, and trimethoprim/sulfametoxazole (SXT) antibiotics are 72% (36/50), 80% (40/50), 74% (37/50), 80% (40/50), 80% (40/50), 82% (41/50), and 74% (37/50) idi. All susceptibility results are shown in **table I**.

It was determined that 92% (46/50) of the strains isolated from the patients produced biofilm. Of these patients, 78.3% (36/46) were male and 21.7% (10/46) were female. The relationship between gender and biofilm was found to be significant (p=0.049). Accordingly, *A. baumannii* strains were more likely to produce biofilms in males than in females. The mean age of patients with biofilm-producing strains was found to be significantly higher than those with non-biofilm-producing strains (p=0.008). It was determined that %76 (38/50) of *A. baumannii* strains were MDR. There was no relationship between the gender and mean age of the patients and MDR (p=0.146, p=0.119, respectively) (**Table II**). However, a statistical significance was found between biofilm formation and being MDR. MDR positive strains appear to be more capable of forming biofilms than MDR negative strains (p=0.038).

Discussion

Colistin is an antibiotic used especially in the treatment of carbapenem-resistant gram-negative bacteria, despite its side effects such as nephrotoxicity. However, with the increase in colistin resistance in recent years, the treatment options of clinicians are gradually decreasing¹⁵.

Many studies have been focused on the comparing broth microdilution, disc diffusion, agar dilution, gradient tests and automated systems to determine the antimicrobial sensitivity of colistin. Antimicrobial susceptibility method of colistin has changed over the years and is still a subject of ongoing debate. The gold standard methods used in comparative studies of antimicrobial sensitivity of colistin are not always the same, which poses a problem for determine the resistance rate of the colistin. Therefore, the results of the antimicrobial sensitivity of colistin are contradictory and misleading. However, EUCAST recommends the broth microdilution method as the reference method for the determination of the Minimum Inhibitory Concentration (MIC) for colistin for *Acinetobacter spp.*¹⁶.

Table I: Antibiotic susceptibility profiles of *A. baumannii* strains.

Antibiotic	Sensitive (n, %)	Resistant (n, %)
Amikacin	14, 28%	36, 72%
Ciprofloxacin	10, 20%	40, 80%
Gentamicin	13, 26%	37, 74%
Imipenem	10, 20%	40, 80%
Levofloxacin	10, 20%	40, 80%
Meropenem	9, 18%	42, 82%
SXT	13, 26%	37, 74%
Colistin*	49, 98%	1, 2%

SXT: Trimethoprim/sulfamethoxazole

*Colistin resistance by broth microdilution method

Table II: Biofilm and MDR properties of *A. baumannii* strains.

	Biofilm negative	Biofilm positive	p-value	MDR negative	MDR positive	p-value
Toplam	4 (8%)	46 (92%)		12 (24%)	38 (76%)	
Average age	44.74±22.99	67.50±15.14	0.008*	59.08±18.12	67.76±16.02	0.119
Male	1 (2.7%)	36 (97.3%)	0.049*	7 (18.9%)	30 (81.1%)	0.149
Female	3 (23.1%)	10 (76.9%)		5 (38.5%)	8 (61.5%)	

MDR: Multi-drug resistant *Statistically significant.

Many surveillance programs have been initiated to monitor antimicrobial resistance in all countries, including the Global Antimicrobial Resistance and Use Surveillance System (GLASS), the European Antimicrobial Resistance Surveillance Network (EARS-Net), and Central Asian and European Surveillance of Antimicrobial Resistance (CAESAR). A report of colistin resistance in bloodstream infections (BSIs) from the SENTRY Antimicrobial Surveillance Program from 2009 to 2016 showed a resistance rate 3.1% in *A. baumannii*¹⁷. The CANWARD surveillance study indicated that *A. baumannii* colistin resistance rates of approximately 2.5% between 2007 and 2016 for Canada¹⁸. The National Antimicrobial Resistance Surveillance Center, Thailand (NARST) also study colistin resistance in clinically important microorganisms and reported that the resistance rates to colistin for *A. baumannii* were less than 5% in 2019¹⁹. In our study, the resistance rate of the colistin was 2%. Unfortunately, our study is the first report for the colistin resistance in Northern Cyprus. Therefore, we were not compare our results.

The most important difficulty in colistin susceptibility tests is the problems in determining resistance²⁰. There are different test methods to detect colistin susceptibility such as automated systems, broth microdilution, and agar dilution, which are phenotypic method²¹. Since polymyxins are big cationic peptide molecules, their distribution on the agar surface is not good, and therefore, disk diffusion and gradient tests are not recommended for susceptibility tests^{14,22}.

While biofilm positivity was 92% in all *A. baumannii* strains examined in our study, this rate was 97.4% in MDR *A. baumannii* strains. This provides that there is a parallel relationship between biofilm formation and antibiotic resistance. When similar studies in the literature are examined, it is reported that *A. baumannii* strains produce high levels of biofilm. Amin et al. reported that biofilm formation was observed in 55 (85.9%) of 64 *A. baumannii* isolates¹¹. In another study, the rate of biofilm formation in MDR *A. baumannii* strains was reported as %75.8²³. In the study of Yang et al., biofilm genes were investigated by molecular methods 154 *A. baumannii* strains and a total of 93.5% (15.6% weak, 32.4% moderate, 45.4% strong) biofilm positivity was detected²⁴. The rate of biofilm formation in our study was found to be relatively high, especially in MDR *A. baumannii* strains.

A. baumannii strains isolated from patients hospitalized in the ICU of a university hospital in Northern Cyprus were examined and carbapenem resistance was found at a rate of 70.7%. The main point that the study wanted to emphasize was the resistance gradually increased between 2016 and 2018¹². The MDR rate was 76% in our study, shows that antibiotic resistance of *A. baumannii* strains continues to increase over the years in our region.

Conclusion

EUCAST and CLSI recommendation reference method is broth microdilution method for colistin susceptibility test. Since the broth microdilution method is usually a laborious and expensive method, it is difficult to use in routine laboratories. In addition, we think that necessary precautions should be taken considering the high rate of biofilm formation detected in our study. The relationship between biofilm and MDR shows that inappropriate and incorrect antibiotic use and the lack of necessary sterilization and disinfection procedures in hospital environments can increase the effect on mortality rates, especially in hospitalized patients.

Conflict of Interest

No conflicts of interest between the authors and / or family members of the scientific and medical committee members or members of the potential conflicts of interest, counseling, expertise, working conditions, share holding and similar situations in any firm.

Authorship Contributions

Idea/Concept: Meryem Güvenir, Anas M.J. Jamal Masalmeh; Design: Meryem Güvenir; Control/Supervision: Meryem Güvenir, Kaya Sür; Data Collection and/or Processing: Emrah Güler, Anas M.J. Jamal Masalmeh; Analysis and/or Interpretation: Meryem Güvenir, Emrah Güler; Literature Review: Meryem Güvenir, Emrah Güler, Anas M.J. Jamal Masalmeh; Writing the Article: Meryem Güvenir, Emrah Güler, Anas M.J. Jamal Masalmeh; Critical Review: Meryem Güvenir, Kaya Sür.

References

1. Li J, Turnidge J, Milne R, Nation RL, Coulthard K. In Vitro Pharmacodynamic Properties of Colistin and Colistin Methanesulfonate against *Pseudomonas aeruginosa* Isolates from Patients with Cystic Fibrosis. *Antimicrob Agents Chemother*. 2001;45(3):781-5.
2. Boisson M, Gregoire N, Couet W, Mimoz O. Colistin in critically ill patients. *Minerva Anestesiol*. 2013;79(2):200-8.
3. Falagas ME, Kasiakou SK, Saravolatz LD. Colistin: The Revival of Polymyxins for the Management of Multidrug-Resistant Gram-Negative Bacterial Infections. *Clin Infect Dis*. 2005;40(9):1333-41.
4. Yahav D, Farbman L, Leibovici L, Paul M. Colistin: new lessons on an old antibiotic. *Clin Microbiol Infect*. 2012;18(1):18-29.
5. Galani I, Kontopidou F, Souli M, Rekatsina P-D, Koratzanis E, Deliolanis J, et al. Colistin susceptibility testing by Etest and disk diffusion methods. *Int J Antimicrob Agents*. 2008;31(5):434-9.
6. Tan TY, Ng SY. Comparison of Etest, Vitek and agar dilution for susceptibility testing of colistin. *Clin Microbiol Infect*. 2007;13(5):541-4.
7. Jayol A, Nordmann P, Lehours P, Poirel L, Dubois V. Comparison of methods for detection of plasmid-mediated and chromosomally encoded colistin resistance in Enterobacteriaceae. *Clin Microbiol Infect*. 2018;24(2):175-9.
8. Clinical and Laboratory Standards Institute (CLSI). Performance standards for antimicrobial susceptibility testing; 23rd informational supplement, document M100-S27. Wayne, PA; 2017.
9. European Committee on Antimicrobial Susceptibility Testing (EUCAST). Breakpoint tables for interpretation of MICs and zone diameters. Version 7.1 [Internet]. 2017. Available from: <http://www.eucast.org>
10. Çalı A, Çelik C, Tutar U, Bakıcı MZ. Biofilm Formation Activities of Isolated Microorganisms from Hospitalized Patients. *Kocaeli Med J*. 2018;7(3):82-8.
11. Gürpınar Ö, Ergin A, Zarakolu P, Köseoğlu Eser Ö. Biofilm Production and Presence of Virulence Genes in Invasive and Non-invasive *Acinetobacter baumannii* Isolates. *FLORA*. 2021;26(4):720-6.
12. Güvenir M, Güler E, Süer K. Carbapenem Resistance Profile of *Acinetobacter baumannii* Complex Strains in the Intensive Care Unit of a University Hospital in Northern Cyprus: 3 Year Follow-up. *Türk J Intensive Care*. 2021;19:118-22.
13. Ceylan MR, Karahocagil MK, Karagöz A, Çıkman A, Durmaz R. The Investigation of Clonal Relationship Among Multiple Drug Resistant *Acinetobacter baumannii* Isolates with Pulsed-Field Gel Electrophoresis. *Journal of Harran University Medical Faculty*. 2020;17(2):297-305.
14. Manchanda V, Sanchaita S, Singh N. Multidrug resistant *Acinetobacter*. *J Glob Infect Dis*. 2010;2:291-304.
15. Tanrıverdi Çaycı Y, Çınar C, Bilgin K, Gür Vural D, Birinci A. Comparison of the Results of the Microdilution and Automated System in Determination of Colistin Resistance. *J DU Health Sci Inst*. 2020;10(3):297-301.
16. Recommendations for MICdetermination of colistin (polymyxin E) As recommended by the joint CLSI-EUCAST Polymyxin Breakpoints Working Group. EUCAST 2016; 22. 7.
17. Diekema DJ, Hsueh PR, Mendes RE, Pfaller MA, Rolston KV, Sader HS, et al. The Microbiology of Bloodstream Infection: 20-Year Trends From the SENTRY Antimicrobial Surveillance Program. *Antimicrob. Agents Chemother*. 2019;63(7):e00355-19.
18. Zhanel GG, Adam HJ, Baxter MR, Fuller J, Nichol KA, Denisuk AJ, et al. 42936 Pathogens From Canadian Hospitals: 10 Years of Results, (2017-16) From the CANWARD Surveillance Study. *J. Antimicrob. Chemother*. 2019;74 (Suppl 4):iv5–iv21.
19. National Antimicrobial Resistant Surveillance Center, T (2020). Antibiogram 2019 (Jan - Dec). Available at: <http://narst.dmsc.moph.go.th/antibiograms.html>
20. Vasoo S. Susceptibility Testing for the Polymyxins: Two Steps Back, Three Steps Forward?. *J Clin Microbiol*. 2017;55(9):2573-82.
21. Şafak B, Tombak Ö, Eren Topkaya A. Comparative Evaluation of VITEK 2 and Broth Microdilution Methods for Colistin Antimicrobial Susceptibility Test. *Namık Kemal Medical Journal*. 2020;8(1):73-8.
22. Tüzemen NÜ, Efe K, Akalin H, Özakin C. Retrospective Evaluation of Colistin-Resistant Isolates in Automated System by Gradient Diffusion Method and Broth Microdilution Method. *Klinik Dergisi*. 2019;32(1):57-61.
23. Sebit B, Aksu B, Karahasan Yağcı A. Biofilm production and biocidal efficacy in multi-drug resistant *Pseudomonas aeruginosa* and *Acinetobacter baumannii* isolates. *Int J Antisept Disinfect Steril*. 2016;1(1):7-12.
24. Yang CH, Su PW, Moi SH, Chuang LY. Biofilm Formation in *Acinetobacter baumannii*: Genotype-Phenotype Correlation. *Molecules*. 2019;24:1849.

Assessment of pubertal delay in adolescents with sickle cell anemia in two health facilities in Cameroon

Evaluación del retraso puberal en adolescentes con anemia falciforme en dos centros de salud de Camerún

Andreas Chiabi¹ , Ladwena Shuymuh¹ , Cecilia Fomenky¹ , Kate Kan¹ , Denis Nsame² 

1. Department of Clinical Sciences, Faculty of Health Sciences, University of Bamenda.

2. Department of Pediatrics, Regional Hospital Bamenda, Cameroon

Corresponding author

Andreas Chiabi

E-mail: andy_chiabi@yahoo.co.uk

Received: 8 - I - 2023

Accepted: 10 - II - 2023

doi: 10.3306/AJHS.2023.38.03.94

Abstract

Objectives: Onset and progression of puberty is reported to be delayed in children with sickle cell anemia. This study sought to determine the prevalence, assess pubertal delay and evaluate the factors associated with pubertal delay in adolescents with SCA.

Methods: We conducted a cross-sectional analytic study on 72 sickle cell adolescents, at the sickle cell clinics of the Regional Hospital Bamenda and Nkwen Baptist Hospital in Cameroon, from 15th February 2022 to 20th June 2022. We assessed sociodemographic variables, clinical and Tanner stages of the participants. Chi square test was used to test for associations, and statistical significance was set at $p < 0.05$.

Results: Pubertal delay was found in 48.5% of participants with a male predominance of 75.0%. The mean age at onset of puberty (B2) in girls with delay was 13.3 ± 1.4 years compared to 15 ± 1.4 years in those without delay, with observe difference statistically significant ($p = 0.001$). The mean age of menarche was delayed by 2.3 years in sicklers with delay. Amongst males, the mean age at onset of puberty (G2) was 14.6 ± 1.5 in sicklers with delay compared to 16.9 ± 1.9 in sicklers with no delay and was statistically significant ($p = 0.001$). Amongst the factors evaluated receiving three or more blood transfusions was significantly associated with pubertal delay. (AOR= 5.7(1.7-19.2) and $p = 0.01$).

Conclusion: A high prevalence of pubertal delay (48.5%) was recorded amongst children with sickle cell anemia. The mean age of menarche was delayed by 2.3 years in sicklers with pubertal delay. Three or more transfusions were significantly associated with pubertal delay.

Key words: Pubertal delay, Adolescents, Sickle cell anemia, Assessment.

Resumen

Objetivos: Se informa que el inicio y la progresión de la pubertad se retrasan en niños con anemia de células falciformes. Este estudio buscó determinar la prevalencia, evaluar el retraso puberal y evaluar los factores asociados al retraso puberal en adolescentes con SCA.

Métodos: Realizamos un estudio analítico transversal en 72 adolescentes con anemia falciforme, en las clínicas de anemia falciforme del Hospital Regional Bamenda y el Hospital Bautista Nkwen en Camerún, del 15 de febrero de 2022 al 20 de junio de 2022. Evaluamos variables sociodemográficas, etapas clínicas y de Tanner de los participantes. Se usó la prueba de chi cuadrado para probar las asociaciones y la significación estadística se fijó en $p < 0,05$.

Resultados: Se encontró retraso puberal en el 48,5% de los participantes con un predominio masculino del 75,0%. La edad media de inicio de la pubertad (B2) en las niñas con retraso fue de $13,3 \pm 1,4$ años en comparación con $15 \pm 1,4$ años en las que no tenían retraso, observándose una diferencia estadísticamente significativa ($p = 0,001$). La edad media de la menarquia se retrasó 2,3 años en las falciformes con retraso. Entre los hombres, la edad media de inicio de la pubertad (G2) fue de $14,6 \pm 1,5$ en las falciformes con retraso en comparación con $16,9 \pm 1,9$ en las falciformes sin retraso y fue estadísticamente significativa ($p = 0,001$). Entre los factores evaluados, recibir tres o más transfusiones de sangre se asoció significativamente con el retraso puberal. (ORA= 5,7(1,7-19,2) y $p = 0,01$).

Conclusión: Se registró una alta prevalencia de retraso puberal (48,5%) entre los niños con anemia de células falciformes. La edad media de la menarquia se retrasó 2,3 años en las drepanocíticas con retraso puberal. Tres o más transfusiones se asociaron significativamente con retraso puberal.

Palabras clave: Retraso puberal, Adolescentes, Anemia de células falciformes, Evaluación.

Introduction

Sickle cell anaemia (SCA) is an autosomal recessive disease characterized by crescent- or sickled shape red blood cells due to a point mutation in the beta globin chain of haemoglobin (Hb) in chromosome 11 causing the hydrophilic glutamic acid to be replaced with the hydrophobic valine at the 6th position^{1,2}. According to World Health Organisation (WHO) about 5% of the world's population carry genes for haemoglobinopathies and 2.9% carries mutation for SCA^{3,4}. In a state of low oxygen, decreased pH, dehydration and infection, erythrocytes alter their shape *in vivo* and undergo repeated cycle of sickling and unsickling until they become irreversibly sickled. This in turn reduce blood supply to tissues leading to organ malfunction as well as complications involving many systems, which in the long run affects development⁵⁻⁷.

The clinical manifestations of SCA most often begins as from 6 months, with painful swelling of hands and or feet, severe painful crises, recurrent infections, bone and joint necrosis and priapism². Moreover, deleterious consequences such as vaso-occlusion, haemolysis, infection and organ dysfunction occur in these set of population and delayed puberty happens to be one of the prominent complications SCA patients experienced. Pubertal delay is the absence of breast development in girls by 13 years of age and absence of testicular growth to at least 4mL in volume or 2.5 cm in length in boys by 14 years of age⁸. Pubertal changes occur at different ages depending on various genetic and environmental influence. Amongst children with sickle cell anaemia the onset of puberty is affected mainly due to chronic hypoxia from recurrent vaso-occlusive events which together with chronic anaemia causes hypoplasia of pituitary gland and gonads. Consequently, altering the process that initiate complex neuroendocrine machinery for the pulsatile secretion of gonadotropin releasing hormone (GnRH) in the hypothalamic pituitary-gonadal (HPG) axis^{8,9}. In addition, the toxicity of iron and increase basal metabolism secondary to haemolysis and multiple transfusions also affects these axis hence delayed pubertal development^{9,10}.

In South America, Gomes et al, carried-out a study on Growth and puberty in a prospective cohort of patients with SCA and found that, patients with SCA showed growth impairment and pubertal delay of 46.66% compared with 6.66% of healthy controls¹¹. Uchendu et al in Nigeria in a study to evaluate sexual maturity among adolescent males, SCA patients showed delayed onset and completion of sexual maturation compared to others¹². A similar study by Betoko et al in Yaounde on puberty during sickle cell anemia noted that 27.3% of girls and 10% of boys with SCA had delayed puberty with recurrent infections and low Hb being the leading associated factors during the study⁹.

So far no study on puberty in sickle cell anemia has been done in the North West Region of Cameroon. Therefore this study will focus in determining the prevalence, assessing pubertal delay and evaluating the factors associated with pubertal delay in adolescents with SCA in the Regional Hospital Bamenda (RHB) and Nkwen Baptist Hospital (NBH).

Materials and methods

Study Setting

This study was conducted in the general paediatric units of 2 hospitals in Bamenda (the Regional Hospital Bamenda and Nkwen Baptist Hospital) found in the North West Region of Cameroon. These two hospitals have specialised units for the follow up of sickle cell patients.

Study design, population and selection criteria

Cross-sectional analytic study, at the general pediatric ward of the Regional Hospital Bamenda and Nkwen Baptist hospital specifically in the sickle cell units. We assessed pubertal delay in adolescents with sickle cell anemia. This study was carried out over a period of 4 months, 15th February to 20th June 2022. The study population comprised all SCA patients being followed up at the sickle cell clinic of the aforementioned hospitals during the study period. A consecutive sampling method was used in recruiting the study population.

Included in our study, were children in the age group of 8-19 years whose genotypes have been confirmed by Hb electrophoresis and are regularly followed up in the RHB and NBH. The age group of 8-9 years was chosen because in Cameroon, puberty usually begins as from the age of 8 and 9 years in girls and boys respectively, and progresses to adolescence at 19 years. We excluded chronic pathologies (heart failure, HIV, renal pathologies), and those who did not give in their consent.

Data collection

For each participant that was eligible for the study, a verbal interview was done using an adequately pre-designed questionnaire to interview participants. The information gotten from the participants and /or caregivers and parameters measured were then filled by the investigator into the questionnaire. A total of 85 participants were approached. After elimination using both the inclusion and exclusion criteria, 72 participants were included in the study.

Data analysis

Data were entered into SPSS for windows version 23.0, Microsoft excel sheet 2021, Epi info version 7 and WHO Anthro version 3.2.2 statistical software for analysis and analysis was done. Chi-square test was used to compare categorical variables while the student-t test

was used to compare the mean values. A p-value < 0.05 was considered as statistically significant.

Ethical considerations

Ethical clearance was obtained from the institutional Review board of Nkwen Baptist hospital and of the Faculty of Health Sciences, University of Bamenda, while administrative authorization was obtained from the North West Regional Delegation of Public Health, as well as directors of the aforementioned hospitals. Before obtaining information from the participants, their assent and consent were also obtained. Participant anonymity and confidentiality were maintained throughout the period of study.

Results

Majority of the 72 children followed up during the study period were between the age group 10-15years (43.1%), and of male predominance (58.3%), however about 65.3% were underweight (Table I). Forty were males, and 30 females giving a sex ratio of 1.3. In addition, majority of children were diagnosed as early as between the ages 1-5years with about 37.5% presenting with more than 2 crises and more than half already being transfused at least once per year.

Table I: Sociodemographic characteristics of the children.

Variable	SCAa(N=72)	
	Number	%
Age Range (in years)		
[8-10]	25	34.7
]10-15[31	43.1
≥15	16	22.2
Sex distribution		
Male	42	58.3
Female	30	41.7
Level of education		
None	3	4.2
Primary	41	56.9
Secondary/High	26	36.1
Higher	2	2.8
BMIb		
<18.5[47	65.3
]18.5-24.9]	23	31.9
≥25	2	2.8

aSickle Cell Anemia b Body Mass Index

Table II: Mean age at Different Tanner Stages for Breast Development in Girls.

Variable	Number		P-Value	Mean (±SDa)		Age	P-Value
	Delay	No Delay		Delay	No delay		
B1	3 (75)	0	0.04	14±1.4	0	0.001	
B2	1 (25)	2 (25)		13.0±1.4	15±1.4		
B3	00	3 (37.5)		00	16.3±1.5		
B4	00	2 (25)		00	17±2.8		
B5	00	1 (12.5)		00	19±0.0		
Total	4 (100)	8 (100)					
Menarche	1 (16.7)	5 (83.3)		14.6±1.5	16.9±1.9		0.001

a standard deviation

Girls without delay were older compared to those with delay at the onset of puberty (B2). The mean age at onset of breast development in sicklers with delay was 13.3±1.4 compared to 15.0±1.4 in those with no delay and was statistically significant (P=0.001). The proportions between the overall breast development in delay and no delay was statistically significant(P=0.04) (Table II).

In boys, the mean age at Tanner stage 2 of testicular development (G2) in male sicklers with delay was lower (14.8±1.8 years) against 16.0±2.0 years for those without delay with statistically significant value (P=0.001). The proportions between the overall genital development in delay and no delay was statistically significant (P=0.005) (Table III). The mean age of Tanner stage 2 pubic hair growth (P2) in sicklers without delay was higher compared to those with delay with a statistically significant (P= 0.001). The proportions between the overall pubic hair development in delay and no delay was statistically significant (P=<0.000) (Table IV). About 16.7% of sicklers with delay had their first menstruation compared to 83.3% of sicklers with no delay.

The mean age of menarche was 16.9±1.9 in sicklers with pubertal delay compared to 14.6±1.5 in no delay with a statistical significant of (P = <0.001) (Table III). Pubertal delay was noted in 48.5% of sicklers with a high rate recorded in males (75.0%). The mean age (±SD) of all sicklers with pubertal delay was 14.7(±1.53), and it was higher in males (15.0±1.9) compared to females (13.8±1.0).Amongst the factors evaluated, only number of blood transfusion over three statistically influence puberty delay (AOR= 5.7(1.7-19.2) and P=0.01) and were 32 times more prone to PD (Table V). None of the sociodemographic factors were associated with pubertal delay (Table VI).

Table III: Mean age at Different Stages for Testicular Development.

Variable	Number		P-Value	Mean (±SDa)		Age	P-Value
	Delay	No Delay		Delay	No delay		
G1	3 (25)	0	0.005	15±1.4	0	0.001	
G2	9 (75)	3 (33.3)		14.8±1.8	16.0±2.0		
G3	00	1 (11.1)		00	16.0±0		
G4	00	2 (22.2)		00	18.0±1.4		
G5	00	3 (33.3)		00	18.3±1.2		
Total	12 (100)	9 (100)					

Table IV: Mean age at Different Tanner Stages for Pubic Hair Development.

Variable	Number		P-Value	Mean (±SDa)		Age	P-Value
	Delay	No Delay		Delay	No delay		
P1	15(93.8)	0	0.000	14.6±1.5	0	0.001	-
P2	1(6.2)	8(47.1)		15±0.0	15.6±1.3		
P3	00	3(17.6)		00	17.3±2.1		
P4	00	2(11.8)		00	18.0±1.4		
P5	00	4(23.5)		00	18.5±1.0		
Total	16(100)	17(100)					

Table V: Factors Associated with Delayed Puberty from the Disease.

Variable	Delay N=16 ^a	No delay N=17 ^b	Binary regression		Multivariate regression	
Variable	Frequency (%)	Frequency (%)	OR [95%CI]	P-value	AOR [95%CI]	P-value
Gender						
Male	12 (60.0)	8 (40.0)	3.4 [0.8-14.8]	0.11	2.7 (0.5-13.1)	0.2
Female	4 (30.8)	9 (69.2)	Reference	Reference		
BMI^c						
<18.5	13 (65.0)	7 (35.0)	6.2 [1.3-30.2]	0.02	5.7 (1.7-19.2)	0.05
≥18.5	3 (23.1)	10(76.9)	Reference	Reference		
Number of transfusions ever received						
≥3	15 (65.2)	8 (34.8)	16.9 (1.8-158.1)	0.01	32 (2.2-482.1)	0.01
<3	1 (10.0)	9 (90.0)	Reference	Reference		
Number of transfusions per year						
≥3	8 (57.1)	6 (42.9)	1.8 [0.5-7.4]	0.4	1.6 (0.4-6.8)	0.5
<3	8 (42.1)	11 (57.9)	Reference	Reference		
Number of crisis per year						
≥3	8 (53.3)	7 (46.7)	1.4 (0.4-5.7)	0.6	1.5 (0.4-6.0)	0.6
<3	10 (55.6)	8 (44.4)	Reference	Reference		
Hospitalizations per year						
≥3	8 (57.1)	6 (42.9)	1.8 [0.5-7.4]	0.4	1.5 (0.4-6.6)	0.6
<3	8 (42.1)	11 (57.9)	Reference	Reference		
Baseline haemoglobin g/dl						
<7	7 (46.7)	8 (53.3)	0.9 (0.2-3.5)	0.9	1 (0.1-6.0)	0.8
≥7	9 (50.0)	9 (50.0)	Reference	Reference		

Table VI: Sociodemographic Factors Associated with Delayed Puberty.

Variable	Delay N=16 [*]	No delay N=17 ^{**}	Binary regression		Multivariate regression	
Variable	Frequency (%)	Frequency (%)	OR [95%CI]	P-value	AOR [95%CI]	P-value
Age of PCG						
≤40	9 (40.9)	13 (59.1)	0.4 (0.1-1.8)	0.2	0.2 (0.03-1.5)	0.1
>40	7 (63.6)	4 (36.4)	Reference	Reference		
Level of education						
<Secondary	8 (44.4)	10 (55.6)	0.7 (0.2-2.8)	0.6	0.8 (0.2-3.2)	0.7
≥ Secondary	8 (53.3)	7 (46.7)	Reference	Reference		
Occupation						
Liberal	14 (51.9)	13 (48.1)	2.2 (0.3-13.8)	0.4	1.8 (0.3-12.3)	0.5
Non-liberal	29 (33.3)	4 (66.7)	Reference	Reference		
Marital status						
Single	8 (53.3)	7 (46.7)	1.4 (0.4-5.7)	0.6	1.3 (0.3-5.33)	0.7
Living as couple	8 (44.4)	10 (55.6)	Reference	Reference		
Socioeconomic status						
< Middle	9 (3)	3 (17.6)	5.3 (1.1-26.6)	0.04	5.3 (1.0-29.4)	0.06
≥Middle	7 (57.6)	14 (82.4)	Reference	Reference		

OR=Odds ratio, C. I=Confidence Interval, N=16^{*} and 17^{**}: Number of sicklers with and without delay, AOR=Adjusted odds ratio, PCG=Primary care-giver

Discussion

For pubertal assessment, the onset and completion of sexual maturation among sicklers was noted to be delayed. Below the age of 13 years, only about 38.5% of the study population had attained stage 2 for breast and pubic hair. However, there was a relative delay in children with SCA below 13years and 14 years in girls and boys respectively.

The results obtained in our study reported that, girls without delay (13-19 years) at each level of pubertal stages were older than those with delay with a gap of 2.0 years at B2. The mean age of female sicklers with delay at the onset of puberty B2 was 13.0±1.4 years this is

lower than the reports by Uchendu et al in Nigeria with a mean age of 14.7±1.5 years¹³. The delay in the onset of puberty amongst girls observed in this study may be due to the deleterious effects of hypoxia and chronic hemolysis on the hypothalamic-pituitary-gonadal axis⁹.

The mean age of menarche in sicklers with delay was 14.6±1.5 years. These results were lower than the findings of M'Pemba et al (15.2 years ± 1.6). In addition, sergeant et al in Jamaica girls demonstrated that the mean age at menarche in sicklers was 15.4 years and they noted that greater weight was associated with earlier age at menarche and weight status was a predictive

factor for the age of menarche in their cohort¹⁴. This delay in the onset of menses could be explained by low weight and low BMI identified in SCA patients with delay compared to others in our study. The notion of target weight is described in literature as the determining factor for menarche in girls¹⁵.

Amongst boys, sickle cell anemic patients showed delay in their ages of attainment of corresponding genital stages of development. Boys without delay were older than boys with delay at the onset of puberty (G2) with a gap of 2.8 years. The mean age of male sicklers with delay at the onset of puberty (stage G2) was 14.8 ± 1.8 (G2) and this results were slightly higher than the findings of Uchendu et al in Nigeria who found that onset of puberty in male sicklers started at 14.7 ± 1.5 years¹³. Our results reflect delayed onset of puberty among boys and can be explained by recurrent vaso-occlusive crises which lead to hemolysis and chronic anemia. However multiple blood transfusions and chronic hemolysis may induce iron overload which is toxic for the pituitary gland and gonads¹⁶. M'Pemba et al found hemoglobin level of less than 7 g / dl to be associated with delayed testicular development in contrast to our study. This may suggest that anemia is a deleterious factor for testicular development. However, a low hemoglobin level exposes the patient to high transfusion requirements which could lead to an iron overload, toxic for gonadal cells¹⁶.

Globally in our study, the overall prevalence of pubertal delay amongst sicklers was reported to be 48.5% with a male predominance (75%). A previous study in Cameroon in 2019 reported lower findings: 27.3% in girls and 10% in boys⁹. This difference could be explained by a difference in sampling methods, sample size and the age groupings in our study. Our results were similar to the proportions reported in previous studies around the world which varies from 37% to 50% for girls and 28.57-73 % for boys^{17,18}. These could be explained by the similar size of their study populations with ours though their study groups included adolescents and young adults who were older than our subjects. This fact may have increased the probability to have a greater proportion of delayed puberty with respect to age groups.

Amongst the factors evaluated, multiple blood transfusions, low BMI and low socioeconomic class were found to be significantly associated with delayed puberty on bivariate analysis and on multivariate analysis we noted that, the number of blood transfusions received remained the only factor associated with pubertal delay. This was similar to the findings of Betoko et al who also found multiple blood transfusions, to be associated with pubertal delay⁹. This could be explained by the fact that high transfusion can cause iron overload, which is toxic for gonadal cells¹⁶ but this was in contrast to a study by Zemel et al in 2007, who found that blood transfusion status had no effect on pubertal development as it rather improves their health and decrease the number of crises¹⁹.

According to literature, many mechanisms are described for delayed puberty in SCA. Chronic hypoxia related to recurrent vaso-occlusive events and chronic anemia lead to hypoplasia of pituitary gland and gonads⁹. On the other hand, iron overload secondary to hemolysis and multiple transfusions also negatively affects the gonadotropic axis^{10,16}. Micronutrient deficiency is also mentioned by some authors as part of pathogenesis of delayed puberty. Zemel et al. in 2002 found an improvement in weight and height in pre-pubertal children after zinc supplementation²⁰.

In conclusion this study indicates a high prevalence of pubertal delay in adolescents with sickle cell anemia. The mean age of menarche was delayed by 2.3 years in sicklers with pubertal delay. Three or more transfusions were significantly associated with pubertal delay. Therefore, psychological counselling on pubertal development during the follow-up of these children is necessary.

Acknowledgements

We are very grateful to the staff of the pediatric ward of the RHB and NBH for their collaboration during the realization of this work.

Declaration of Competing interest

The authors declare that they have no known competing financial interests or personal relationships that could have influenced the work reported in this paper.

Funding

The authors declare that this study has received no financial support.

References

1. Creary M, Williamson D, Kulkarni R. Sickle Cell Disease: Current Activities, Public Health Implications, and Future Directions. *J Womens Health*. 2007;16(5):575-82.
2. Kliegman RM, Stanton BF, St Geme III JW, Schor NF. *Nelson Textbook of Pediatrics*. 20th ed. Behrman RE, editor. Vol. 2. Philadelphia: ELSEVIER; 2016. 1-5315 p.
3. World Health Organisation WHO. Sickle Cell Anemia. 2006 Apr p. 1–5. Report No.: 59TH.
4. Chemegni CB, Kenmegne AB, Ngo SF, Ngouadjeu E, Megningue NE, Bengondo C, et al. Epidemiological, Clinical and Biological Characteristics of Cameroonian Children and Adolescents with Sickle-Cell Anemia. *Arch Med*. 2018 Feb 14;10(1:6):1-3.
5. Chinenye AH. Physical Growth and Sexual Maturation of Female Adolescent in Sickle Cell Anemia Patients Seen in Lagos, Nigeria. Lagos University Teaching Hospital, Idi-Araba and Sickle Cell Foundation, Nigeria; 2014.
6. Sundd P, Gladwin MT, Novelli EM. Pathophysiology of Sickle Cell Disease. *Annu Rev Pathol*. 2019 Jan 24; 14:263-92.
7. Lichtin AE. Hematology and Oncology. In: Porter RS, editor. *The Merck Manual of Diagnosis and Therapy*. 19th ed. Merck Sharp and Dohme Corp; 2011. p. 942-5.
8. Klein DA, Emerick JE, Sylvester J, Vogt KS. Disorders of Puberty: An Approach to Diagnosis and Management. *Am Fam Physician*. 2017 Nov 1;96(9):590-9.
9. Hauschild M, Theintz G. Severe chronic anemia and endocrine disorders in children. *Rev Med Suisse*. 2007; 3:988-91.
10. Betoko RM, Um SSN, Alima AY, Chelo D, Nengom JT, Simon D, et al. Puberty During Sickle Cell Anemia in Cameroonian Children: A Case Control Study. [cited 2022 Sep 17]. Available from: <https://abstracts.eurospe.org/hrp/0086/hrp0086p1-p739>.
11. Soliman AT, Yasin M, El-Awwa A, Abdelrahman MO, De Sanctis V. Does blood transfusion affect pituitary gonadal axis and sperm parameters in young males with sickle cell disease? *Indian J Endocrinol Metab*. 2013;17(6):962-8.
12. Gomes ICP, Melo HN, Melo SIA, Menezes NV de, Dantas TVP, Cipolotti R. Growth and puberty in a prospective cohort of patients with sickle-cell anaemia: an assessment over ten years. *J Hum Growth Dev*. 2017;27(1):91-8.
13. Uchendu UO, Nwokocha AR, Ikefuna AN, Emodi IJ, Onwasigwe CN. Evaluation of Sexual Maturity among Adolescent Male Sickle Cell Anaemia Patients: The Usefulness of Testicular Volume Estimation. *South Afr J Child Health*. 2010 Mar 31;4(1):11.
14. Uchendu UO, Ikefuna AN, Nwokocha ARC, Emodi IJ. Impact of socioeconomic status on sexual maturation of Nigerian boys living with sickle cell anaemia. *Hematology*. 2010;15(6):414-21.
15. Serjeant GR, Singhal A, Hambleton IR. Sickle cell disease and age at menarche in Jamaican girls: observations from a cohort study. *Arch Dis Child*. 2001 Nov 1;85(5):375-8.
16. Kaplowit P. Link Between Body Fat and the Timing of Puberty. *Am Acad OfPediatrics*. 2008; 121:208-17.
17. Fung EB, Harmatz PR, Lee PDK, Milet M, Bellevue R, Jeng MR, et al. Increased prevalence of iron-overload associated endocrinopathy in thalassaemia versus sickle-cell disease. *Br J Haematol*. 2006;135(4):574-82.
18. M'Pemba-Loufoua AB, Nzingoula Z, Moubouh-Akouala F, Oba A. Développement pubertaire chez la fille drépanocytaire homozygote. A propos de 72 cas. *Bull Soc PatholExot*. 2001;326-9.
19. Zemel BS, Kawchak DA, Ohene-Frempong K, Schall JI, Stallings VA. Effects of Delayed Pubertal Development, Nutritional Status, and Disease Severity on Longitudinal Patterns of Growth Failure in Children with Sickle Cell Disease. *Pediatr Res*. 2007 May;61(5, Part 1):607-13.
20. Zemel BS, Kawchak DA, Fung EB, Ohene-Frempong K, Stallings VA. Effect of zinc supplementation on growth and body composition in children with sickle cell disease. *Am J Clin Nutr*. 2002 Feb 1;75(2):300-7.

Pathogenicity Testing of Microbial Isolates from Refuse Dumps sites and collection centres in Awka metropolis, Nigeria

Pruebas de patogenicidad de aislados microbianos procedentes de vertederos y centros de recogida de basuras en la metrópoli de Awka, Nigeria

Chetachi Blessing Okwuanaso¹ , Ifeoma. B. Enweani-Nwokelo¹ ,
Emmanuel Ifeanyi Obeagu² 

1. Department of Medical laboratory Science, Faculty of Health Sciences and Technology, NnamdiAzikiwe University, Nnewi Campus, Nnewi. 2. Department of Medical Laboratory Science, Kampala International University, Uganda.

Corresponding author

Emmanuel Ifeanyi Obeagu

E-mail: emmanuelobeagu@yahoo.com

Received: 10 - I - 2023

Accepted: 12 - II - 2023

doi: 10.3306/AJHS.2023.38.03.100

Abstract

Introduction: Despite the attendant health risks inherent in waste dump sites, certain individuals make their living by foraging and packing the waste for survival.

Methods: A total of 280 samples were collected from the waste collectors, scavengers, and people living and trading around refuse dump sites, collection centers, and refuse dump sites in Awka Metropolis. The bacterial and fungal isolates were further subjected to pathogenicity testing using Wistar rats.

Results: The histology of the kidneys and lungs was altered except for the control group, which was injected with normal saline. There were moderate and profuse macrophage infiltrations, with Bowman's capsule distorted in the majority of the kidneys. It was observed that none of the microorganisms altered the histology of the liver. The histology of the kidney and the lungs of the albino Wistar rats was altered, which is indicative of pathogenicity.

Conclusión: the pathogenic nature of the organisms isolated in this study indicates that the activities of scavengers and waste collectors pose a serious health risk to the public. This study therefore calls for a proper regulatory system for waste disposal.

Key words: Refuse dump sites, pathogenicity, Waste collectors, Scavengers, Microorganisms, Public health.

Resumen

Introducción: A pesar de los riesgos para la salud inherentes a los vertederos, algunas personas se ganan la vida rebuscando y empaquetando los residuos para sobrevivir.

Material y métodos: Se recogieron un total de 280 muestras de recolectores de residuos, carroñeros y personas que viven y comercian en los alrededores de los vertederos, centros de recogida y vertederos de residuos de la metrópoli de Awka. Los aislados bacterianos y fúngicos se sometieron además a pruebas de patogenicidad utilizando ratas Wistar.

Resultados: La histología de los riñones y los pulmones estaba alterada, excepto en el grupo de control, al que se le inyectó solución salina normal. Había infiltraciones moderadas y profundas de macrófagos, con la cápsula de Bowman distorsionada en la mayoría de los riñones. Se observó que ninguno de los microorganismos alteraba la histología del hígado. La histología del riñón y de los pulmones de las ratas Wistar albinas estaba alterada, lo que es indicativo de patogenicidad.

Conclusión: La naturaleza patógena de los organismos aislados en este estudio indica que las actividades de los carroñeros y recolectores de residuos suponen un grave riesgo para la salud de la población. Por lo tanto, este estudio reclama un sistema de regulación adecuado para la eliminación de residuos.

Palabras clave: Vertederos, patogenicidad, Recolectores de residuos, Carroñeros, Microorganismos, Salud pública.

Introduction

Domestic solid waste is any unwanted or discarded solid materials from residential activities that cause environmental, social and health problems. The World Health Organization refers to waste as something which the owner no longer wants at a given time and space which has no current or perceived market value. In the words of Ikhuoria¹, waste is refuse, garbage, ashes and rubbish that are derived from places of human and animal habitation. He further grouped solid waste elements into two – decomposable refuse and non-decomposable refuse. Nwobu² in his study of solid waste disposal and management in Awka, Anambra state, defined solid waste as anything discarded or unwanted whose physical state is solid or semisolid.

Kimberly³ carried out a study on composition of solid waste in Florida State, United States of America. In his study, he made a classification of solid wastes based on the material composition. These include garbage, or food waste, paper, glass, cars and other household wastes. The daily activities of humans give rise to a large variety of wastes and when these waste materials are disposed off, microorganisms of different types such as bacteria, fungi and worms (helminthes) colonize the waste and begin to degrade them⁴. As a result, they break down the unprocessed or organic components of waste into inorganic forms, which can readily serve as sources of nutrients for a variety of other organisms.

Ajadike⁵, states that urban waste crisis arises in Nigeria because of three fundamental factors namely, rapid increase in urban population, heavy consumption pattern of urban dwellers and the inefficiency of the authorities whose statutory responsibilities includes efficient waste disposal in cities. Adesoji⁶ took a study of solid waste disposal in Ibadan, he discovered that various landfill sites and open dump sites in the town are mismanaged and these sites harbor disease carrying pathogens such as rat, cockroaches, mosquitoes, houseflies, fleas etc.

It is evident that most environmental, economic and health related problems in human and the environment can be attributed to the incidence of solid wastes. This work goes further to ascertain the situation in the study area.

Though there are available methods of waste disposal, such as composting, landfill and incineration, open dumping continues to be the only method available in Nigeria particularly in major cities like Port Harcourt, Awka, Nnewi and Onitsha even though these are strongly discouraged in the National Sanitation Policy⁷. Wastes are left on the streets for days or weeks, without proper sorting before they are disposed to the final dumpsites or relocated to open lands⁸.

Materials and methods

Study design

This prospective study was performed to determine some microorganisms in individuals associated with refuse dumpsites and collection centers in Awka metropolis. The sampling method used was a Convenience Sampling Technique, a non-probability sampling technique where the subjects [Waste collectors, scavengers and people living/ trading around the refuse dumpsites] were selected based on convenience, accessibility, proximity to the researcher and not necessarily a representative of the entire population.

Study area

The samples were collected in Awka metropolis consisting Awka, Nibo, Nise, Amawbia, Okpuno and Umuokpu, where refuse collecting centers and the main dump site are located.

Ethical consideration

Ethical clearance was obtained from the Faculty of Health Sciences and Technology and Authorization from the Anambra State Waste Management Authority. Informed Consent was also sought from various waste scavengers and waste collectors who willingly volunteered to be part of this study. It entailed the purpose of the study, benefits, privacy/confidentiality and conflict of interest. Participation was absolutely voluntary and each subject had the opportunity to participate or opt out at any point in the course of the survey.

Sampling period and sample population

The study was carried out between June 2016 and August 2016, using scavengers and waste collectors within the age bracket of 18-45 years and Control subjects of same age bracket. A total of 350 samples were collected, 30 samples from individuals living and trading around refuse dump sites, 60 samples from waste collectors, 60 samples from waste scavengers, 10 samples from waste vehicles, 40 samples from waste collection centers and 10 samples from main refuse dump sites, and 140 samples from the Control group.

Microbial analysis

Waste Sample

Waste Samples [20g] were collected from different portion of the main dump sites and collection centers for even distribution, to ensure that no organisms were missed. The samples were collected in sterile containers, using a special spatula. Thereafter, 1g of each prepared waste sample was added into 9ml of 0.1% bacteriological peptone [10-1dilution] shaken vigorously for at least 1 minute. The diluents were left to sediment for a short period. Further ten-fold serial dilutions were made up to 10-4, using sterile pipettes. Cultures from the last 2 dilutions [10-3 and 10-4] were made by transferring an aliquot [0.1ml] into surface dried Nutrient agar, and

MacConkey Agar plates and spread evenly with a spreader [i.e. bent glass rod]. The culture plates were incubated aerobically at 37°C for 24hrs.

Haematoxylin & Eosin staining (H&E)

Sections were freed from wax with xylene for 2mins and brought to distilled water through descending grades of ethyl alcohol [95, 90, and 70] and rinsed in running water; Stained with Ehrlich's haematoxylin for 30 minutes and rinsed in running tap water. They were differentiated with 1% acid alcohol until only nuclei were stained, rinsed in running tap water and 'blued' in Scott's tap water substitute for 3 minutes. Furthermore, the sections were rinsed in tap water, counter stained with Eosin for 2 minutes, dehydrated in ascending grades of alcohol [70, 90, 95], taken back to hot air oven for 5mins where

all traces of water was removed, cleared in xylene and mounted in DPX [Di butyl phthalate polystyrene xylene]. These procedure were successfully carried out with the help of a histopathologist. Cell nuclei would be indicated by blue colour, cytoplasm by pink colour, collagen and muscle fibres by various shades of pink colour.

Statistical analysis

Data collected were subjected to statistical analysis using percentages, Student's t-test and analysis of variance (ANOVA). Values will be deemed significant at $P < 0.05$.

Results

Histology result

Plate 1

A. Control Kidney tissue shows normal histology. Glomeruli and tubules are intact. **B.** Kidney tissue infected with *Candida albicans* from subjects show cellular hyperplasia of the Bowman's capsule epithelial lining with mild infiltration of inflammatory cells within the interstitial tissue. **C.** Kidney tissue infected with *Escherichia coli* from subjects show distorted Bowman's capsule epithelial lining with infiltration of inflammatory cells within the interstitial tissue. **D.** Kidney tissue infected with *Klebsiella pneumoniae* from subjects show mildly distorted Bowman's capsule epithelial lining (H&E x 100).

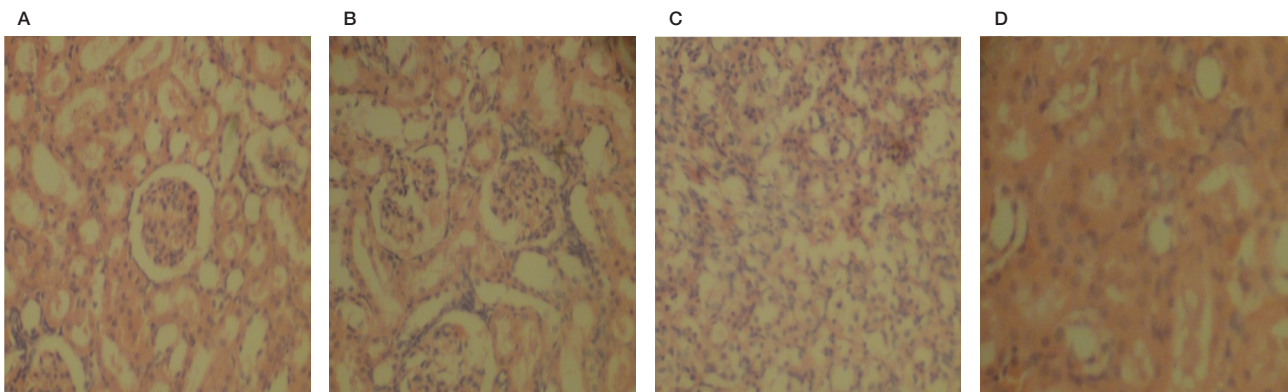

Plate 2

A. Kidney infected with *Aspergillus niger* from subjects show distorted Bowman's capsule epithelial lining with infiltration of inflammatory cells within the interstitial tissue. **B.** Kidney tissue infected with *Staphylococcus aureus* from subjects show distorted Bowman's capsule epithelial lining and edema with infiltration of inflammatory cells within the interstitial tissue. **C.** Kidney tissue infected with *Bacillus subtilis* from subjects show mildly distorted Bowman's capsule epithelial lining. **D.** Kidney tissue infected with *Pseudomonas aeruginosa* from subjects show mildly distorted Bowman's capsule epithelial lining (H&E x 100).

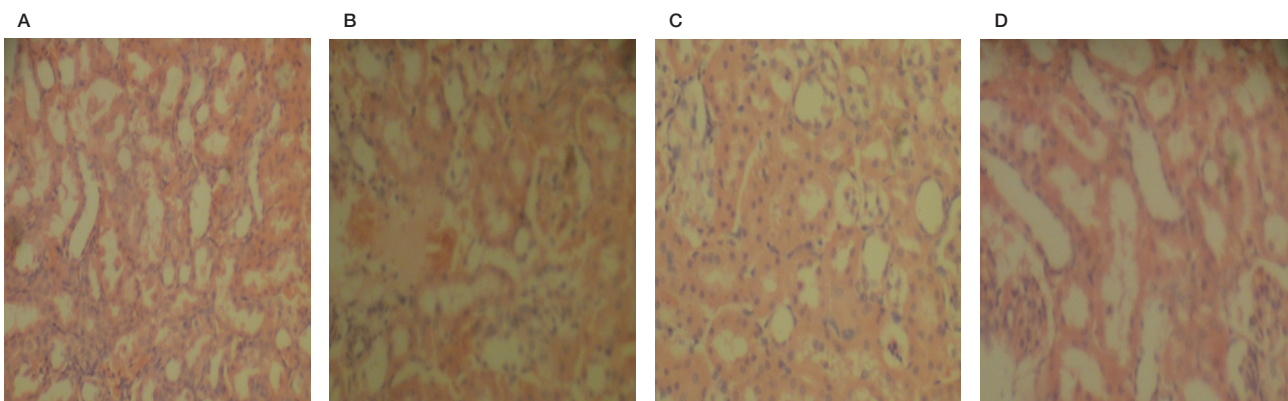
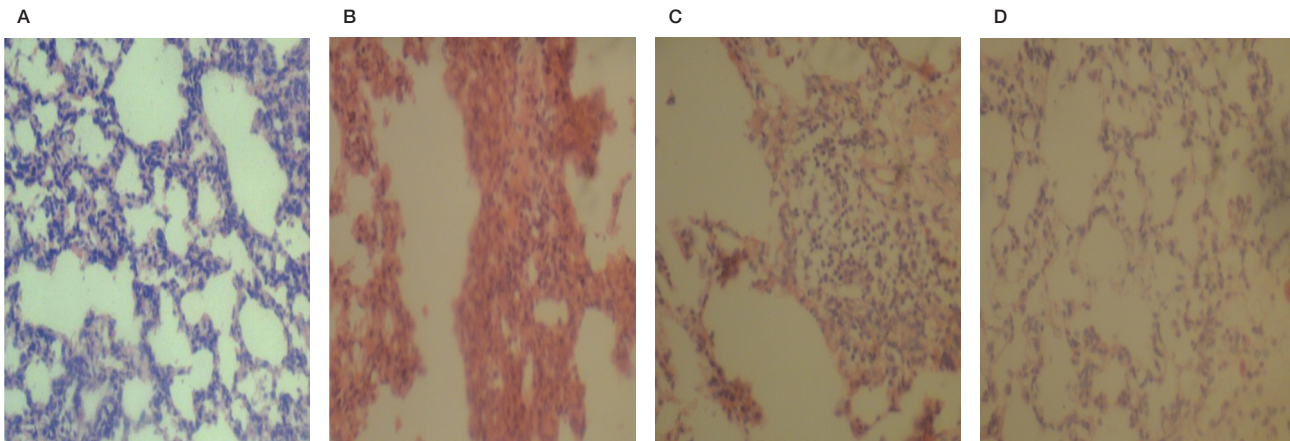
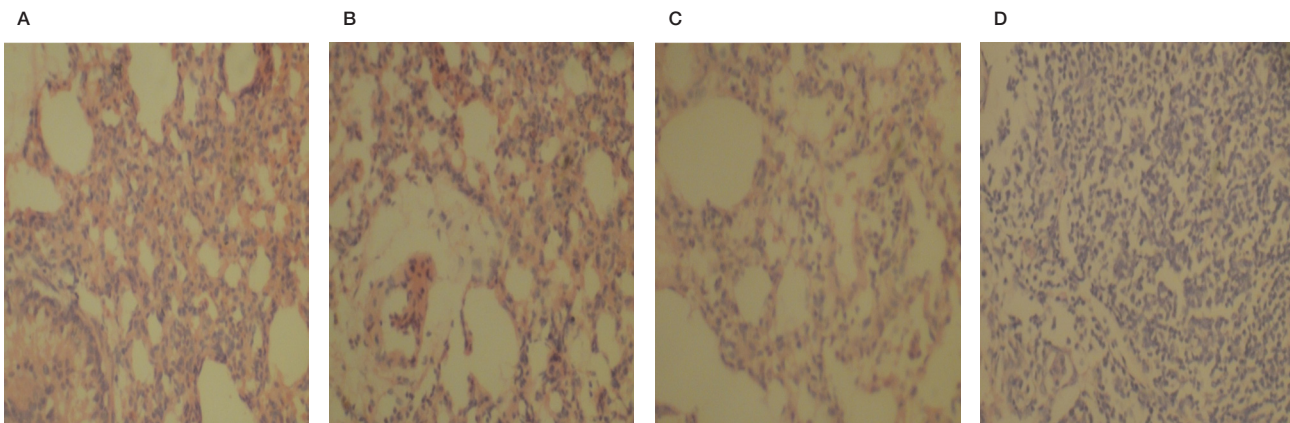

Plate 3

A. Control lung tissue shows normal histology (H&E x 100). **B.** Lung tissue infected with *Aspergillus niger* from subjects show moderate infiltration of inflammatory cells. **C.** Lung tissue infected with *Bacillus subtilis* from subjects show moderate infiltration of inflammatory cells. **D.** Lung tissue infected with *Candida albicans* from subjects shows moderate infiltration of inflammatory cells (H&E x 100).

**Plate 4**

A. Lung tissue infected with *Escherichia coli* from subjects show moderate infiltration of inflammatory cells. **B.** Lung infected with *Klebsiella pneumoniae* from subjects show moderate infiltration of inflammatory cells. **C.** Lung infected with *Pseudomonas aeruginosa* shows moderate infiltration of inflammatory cells. **D.** Lung tissue infected with *Staphylococcus aureus* shows profuse infiltration of inflammatory cells.



Discussion

Wistar rat studies revealed histological alteration of some of the vital organs which included the kidneys and lungs. Observed alteration in these organs may be due to damage to these organs by the isolates, as the same microbial isolates injected into the Wistar rats were later isolated from the lesions found in the organs.

According to the histology results, the kidneys showed cellular hyperplasia of the epithelial lining of the Bowman's capsule and oedema with mild infiltration of inflammatory cells within the interstitial tissues as had been previously reported by Cheong *et al.*⁹ in workers exposed to industrial waste. The lungs showed moderate and profuse infiltration of the inflammatory cells which normally occurs when there is an injury, giving an

insight into the pathogenic nature of the isolates. All the microbial isolates in this study apparently did not have the ability to invade the liver of the rats as these appeared not to be infected. No pathological lesions were observed in any of the control animals. This was an indication that the effects observed with the infected animals might be due to the activity of the microbial isolates with which they were infected indicating that some of the organisms isolated were pathogenic and may cause serious damage to the host, if left untreated. Although none of the experimental rats died when they were exposed to the isolates, these isolates might be opportunistic pathogens and could be hazardous to those body defenses that are compromised. This view was expressed by Chhabra *et al.*¹⁰ where *Aspergillus spp* killed immunosuppressed rat

and altered the histology of the normal rats without killing them. Continuous exposure to these microorganisms may cause harm. Hence, the need of public awareness in respect of the dangers associated with improper waste disposal and management.

Conclusion

All the microbial isolates in this study apparently did not have the ability to invade the liver of the rats as these appeared not to be infected. No pathological lesions were observed in any of the control animals. This was an indication that the effects observed with the infected animals might be due to the activity of the microbial isolates with which they were infected indicating that some of the organisms isolated were pathogenic and may cause serious damage to the host, if left untreated.

Acknowledgement

The authors wish to thank the scavengers, waste collectors, and people living and trading around the refuse dump sites for volunteering themselves to participate in this study.

References

1. Ikhuoria IA. Analysis of the special Attributes and chemical methods of solid waste management in Nigeria. *Environment Review*. 2002; 49 (1).
2. Nwobu E. Solid Waste Disposal and Management in Awka. An unpublished PGD Project, Department of Geography, Meteorology and Environmental Management. NnamdiAzikiwe University, Awka; 2022.
3. Kimberly. Study on composition of solid waste in Florida State, United States of America; 2005.
4. Wachukwu CK, Mbata CA, Nyenke CU. The Health Profile and Impact Assessment of Waste Scavengers (Rag Pickers) in Port Harcourt, Nigeria. *Journal of Applied Sciences*. 2010; 10: 1968-72.
5. Ajadike JC. Urban Solid Wastes; "Problems and Management in Nigeria" in G.E.K. Oformata and P.O.Phil-Eze (eds.) *Geographical perspective on Environmental Problems and Management in Nigeria*, Nsukka Department of Geography, University of Nigeria, Nsukka. 2001.
6. Adesoji AO. *Solid Waste Management Problems in Ibadan* Wiser publication Ltd, Ibadan. 2004.
7. Anthony M. Well Fact Sheet. Solid Waste Disposal in Ghana. Director of Waste Management, Kumasi. Ballows, H., Herman, I.S., (1990). *Manual of Clinical Microbiology*. 5th; 2005.
8. Mbata CA. Studies on the burden of solid waste biodegrading microbes and health risks on waste scavengers in Port Harcourt. Ph.D. Thesis, Nigeria. 2008.
9. Cheong H, Kim EA, Choi J, Choi S, Shi J, Choi DS, et al. Ground rounds: an outbreak of toxic hepatitis among industrial waste disposal workers. *Environmental Health perspective*. 2007; 115: 107-12.
10. Chhabra D, Dhakad NK. Study on pathogenicity of the *Aspergillus* species in environmentally immunosuppressed rats. *Veterinary world*. 2008;1 (3):69-70.

Búsqueda de un patrón clínico para la predicción de colonoscopia patológica en los pacientes participantes de las 2 primeras rondas del Programa de Detección precoz de Cáncer Colorrectal del Hospital Comarcal de Inca

Search for a clinical pattern for the prediction of pathological colonoscopy in patients participating in the first 2 rounds of the Colorectal Cancer Early Detection Program of the Hospital Comarcal de Inca

Marita Trelles^{1,2,3}, **María del Pilar Roca^{2,3,4}** , **Jorge Sastre-Serra^{2,3,4}** , **Mónica Florido¹** , **Eduardo Iyo¹**, **Silvia Patricia Ortega¹** , **Miguel Angel Crespi⁵**, **Carmen Sanchez-Contador⁵** , **Elisa Miró⁵**, **Guillem Artigues⁵** , **José Reyes^{1,2,3}** 

1. Servicio de Digestivo. Hospital Comarcal de Inca. Mallorca. España

2. Grupo Multidisciplinar de Oncología Traslacional, Institut Universitari d'Investigació en Ciències de la Salut (IUNICS), Universitat de les Illes Balears, Palma de Mallorca. España

3. Instituto de Investigación Sanitaria Illes Balears (IdISBa), Hospital Universitario Son Espases, Palma de Mallorca. España

4. Ciber Fisiopatología Obesidad y Nutrición (CB06/03/0043) Instituto Salud Carlos III, Madrid. España

5. Dirección General de Salud Pública i Participació. Conselleria de Salut. Govern de les Illes Balears. España

Corresponding author

José Reyes
E-mail: jose.reyes@hcin.es

Received: 12 - I - 2023

Accepted: 13 - II - 2023

doi: 10.3306/AJHS.2023.38.03.105

Resumen

Introducción: En el desarrollo de los Programas de Detección Precoz de Cáncer Colorrectal (PDPCCR), la colonoscopia es la prueba diagnóstica final, así como el principal factor limitante, este hecho sumado a situaciones como la reciente pandemia por COVID, que puso en mínimos el funcionamiento de varios servicios de endoscopia a nivel nacional, hace que nos planteáramos intentar buscar patrones predictivos que a futuro permitan la priorización de aquellos pacientes con mayor riesgo de endoscopia patológica dentro del programa de cribado, a fin de agilizar el desarrollo de los mismos.

Método: Estudio retrospectivo basado en una muestra de datos clínicos y endoscópicos recopilados de las 2 primeras rondas del PDPCCR del Área de la Tramuntana - Hospital Comarcal de Inca (Mallorca)

Resultados: Se encontró asociación entre la variabilidad de la edad, el sexo y los valores cuantitativos de la sangre oculta en heces inmunoquímica (SOHi) con el riesgo de hallazgos endoscópicos, así como la toma de antiinflamatorios no esteroideos (AINES) y ácido acetilsalicílico (AAS) como factores protectores.

Conclusiones: Hemos podido replicar los resultados de otros estudios, lo que fortalece nuestro programa de cribado, y nos sirve de base para obtener prospectivamente modelos de riesgo más precisos.

Palabras clave: Programa de cribado. Cáncer colorrectal (CCR). Prueba inmunoquímica de sangre oculta en heces (SOHi). Punto de corte de SOHi. Factores de riesgo de CCR.

Abstract

Objective: In the development of the Colorectal Cancer Screening Programme (CRCSP), colonoscopy is the final diagnostic test, as well as the main limiting factor, this fact added to situations such as the recent COVID pandemic, which reduced the operation of several endoscopy services nationwide, makes us consider trying to find predictive patterns that in the future allow the prioritization of those patients with a higher risk of pathological endoscopy within the program, in order to expedite the development of screening programs.

Method: Retrospective study based on a sample of clinical and endoscopic data collected from the first 2 rounds of the CRCSP of the Tramuntana Area - Hospital Comarcal de Inca (Mallorca).

Results: An association between the variability of age, sex and quantitative values of faecal immunochemical test (FIT) with the risk of endoscopic findings, as well as taking NSAIDs and ASA as protective factors, was found.

Conclusions: We have been able to replicate the results of other studies, which strengthens our screening program and also serves us as a basis for prospectively obtaining more accurate risk models.

Key words: Colorectal cancer screening programme (CRCSP). Faecal immunochemical test (FIT). Cut-off value of FIT. Risk factors for CRC.

Introducción

El cáncer colorrectal (CCR) es la neoplasia más frecuente en los países Occidentales. En España, el CCR es globalmente el cáncer más frecuente, con un total de 39.553 nuevos casos, y pasa a ocupar la segunda posición entre los hombres, por detrás del cáncer de próstata, y entre las mujeres, por detrás del cáncer de mama.¹⁻⁴

La mayoría de los cánceres de colon y recto se desarrollan a partir de pólipos adenomatosos. La probabilidad de que un pólipo progrese a cáncer depende del tipo histológico, tamaño y grado de displasia celular. El tiempo medio necesario para completar dicha progresión es larga, probablemente de 10 años o más, lo que hace susceptible de cribado a este tipo de neoplasias.¹

Las pruebas de cribado permiten la detección de la enfermedad en su fase inicial (pólipo o CCR localizado en estadios iniciales), lo que permitiría reducir la incidencia del CCR, mediante la resección de las lesiones precursoras y tratamiento de lesiones en fases tempranas. Tras la extirpación de pólipos, la incidencia de carcinomas disminuye aproximadamente en un 88-90%, en los 6 años siguientes.⁵

La mayoría de los PDPCCR en Europa tiene como estrategia predominante la detección de test de sangre oculta en las heces inmunológico cuantitativo (SOHi) bienal seguido de la colonoscopia. La utilidad del cribado por SOHi quedó demostrada en el estudio de Quintero et al., en el que se valoró la colonoscopia vs la SOHi en el cribado de CCR, encontrando una tasa de detección similar de CCR en ambos grupos, así como una mayor susceptibilidad de participación en el cribado en el grupo de SOHi.⁶

Los test de sangre oculta en heces miden la concentración de hemoglobina humana en las heces, y por el método inmunoquímico (SOHi) se puede realizar una lectura automatizada y seleccionar los valores de corte para clasificar los resultados como positivos o negativos. Los PDPCCR basados en SOHi utilizan un único punto de corte para toda la población objetivo, siendo la decisión del punto de corte establecido todo un desafío. Los PDPCRR deben separar a las personas aparentemente sanas que probablemente tengan una enfermedad de las que probablemente no la tengan, asignando a los participantes con un nivel SOHi superior a un determinado valor de corte (prueba positiva) al grupo que probablemente tengan lesiones, dejando a aquellos con un nivel de SOHi por debajo de cierto valor de corte (prueba negativa) en el grupo que probablemente no tenga CCR.

El valor de corte debe elegirse de modo que las probabilidades de tener una prueba de detección

positiva, dado que se tiene la enfermedad, es lo más alto posible (sensibilidad), mientras que al mismo tiempo maximiza las probabilidades de tener una prueba de detección negativa, dado que no se tiene la enfermedad (especificidad).

Sin embargo, disminuir el valor de corte para obtener una mayor sensibilidad disminuirá inevitablemente la especificidad. El valor de corte óptimo, por lo tanto, depende de qué tan importante se pondere un aumento en la sensibilidad en comparación con la inevitable disminución posterior en la especificidad.

El progresivo envejecimiento de la población, la exposición a factores de riesgo ambientales, los cambios en los hábitos nutricionales y el cribado de CCR, influyen de forma muy marcada en la evolución del número de casos observados de CCR, por tanto es importante tener en cuenta de cara al cribado de CCR que existen diferentes factores que pueden aumentar la probabilidad de que una persona presente pólipos y/o CCR, algunos como la carga genética, la edad o el sexo no son modificables, sin embargo existen otros factores que sí se pueden modificar y que han sido demostrados como factores de riesgo independientes asociados al CCR como el síndrome metabólico, el tabaquismo, el alcohol y la dieta.⁷⁻¹⁰

Asimismo, existen muchas líneas de investigación en el área de la prevención del CCR, y en ese sentido se ha revisado la utilidad de diversos fármacos que podrían tener un papel en la quimioprevención, ya que podrían incidir en las diversas etapas del desarrollo del CCR, y reducir el riesgo del mismo.¹¹⁻¹³

Otro factor a tener en cuenta en la viabilidad y efectividad de los PDPCCR es el número de colonoscopias factibles en las unidades de endoscopia, de manera que se debe realizar una adecuada planificación de la carga de trabajo que supone la puesta en marcha de un PDPCCR para hacerlo sostenible a largo plazo.

En un estudio realizado en nuestro hospital, el Hospital Comarcal de Inca, se revisó dicho aumento de actividad, evidenciándose que la puesta en marcha del PDPCCR provocó un gran incremento en la actividad del gabinete de endoscopia digestiva, principalmente del número de colonoscopias, sin embargo no todo el aumento de actividad fue atribuible directamente al propio programa de cribado, lo que supondría un beneficio para los pacientes no pertenecientes al programa con un descenso del tiempo de demora para la endoscopia.¹⁴

En el contexto del desarrollo de la pandemia por SARS-Cov2, y su impacto sobre la capacidad de trabajo de las unidades de endoscopia, se han propuesto diferentes mecanismos de adaptación para hacer frente a la situación. En un estudio español del PDPCCR de la

región de Aragón, donde se investigaron dos escenarios diferentes, no modificar versus modificar el valor de corte de SOHi, estimando los resultados del programa en dichos escenarios mediante la evaluación de la cantidad de cánceres y adenomas que no se diagnosticaron o no se diagnosticaron a tiempo (retrasados). Encontraron que con el corte actual de SOHi de 20 µg/g, se realizaron 6.606 colonoscopias por cada 100.000 personas invitadas anualmente. Sin modificar este valor de corte, cuando el número de personas invitadas a colonoscopias se redujo en un 10-40%, un elevado número de CCR y adenomas de alto riesgo (34-135 y 73-288/100.000-personas invitadas, respectivamente) no se detectaron. Además, el resultado del escenario de SOHi no modificado se mejoró al priorizar el proceso de selección en función del sexo y la edad, en lugar de reducir aleatoriamente el número de invitados. Cuando el valor de corte se incrementó hasta donde la demanda de colonoscopia coincidió con la disponibilidad de colonoscopia, la cantidad de lesiones perdidas por año se redujeron notablemente (9-36 y 29-145/100.000 personas, respectivamente). Por tanto, asumiendo un desajuste entre la disponibilidad y la demanda de colonoscopias anuales, aumentar el punto de corte de SOHi podría ser más efectivo que reducir aleatoriamente el número de personas invitadas.¹⁵

Fuera del contexto de la pandemia, diferentes estudios han tratado de mostrar cómo la personalización de los puntos de corte de la SOHi según las características del paciente, podría ayudar a mejorar la eficiencia del PDPCCR. En un estudio Holandés, donde se recopilaban los datos prospectivamente del sistema de información de detección nacional, iniciando la primera ronda con un punto de corte de SOHi de 15 µg/g que aumentaron a mitad de la primera ronda a 47 µg/g. Estableciendo para la segunda ronda un punto de corte de 47 µg/g. Los participantes se clasificaron de acuerdo al punto de corte en la primera ronda como participantes SOHi (15,47) o SOHi (47,47) y no participantes anteriores SOHi (np, 47). Las tasas de participación fueron del 93,4% entre los participantes anteriores y del 21,0% entre los no participantes anteriores. Los participantes de SOHi(47,47) tuvieron una tasa de detección de lesiones avanzadas significativamente mayor en la segunda ronda (15,3 frente a 10,4 por cada 1000 participantes) en comparación con los participantes de SOHi(15,47), mientras que su tasa de detección acumulada de lesiones avanzadas a lo largo de las dos rondas fue significativamente menor (45,6 frente a 52,6 por 1.000 participantes). Dichos resultados indican que las tasas de detección de la segunda ronda dependieron del punto de corte del SOHi de la primera ronda, sin embargo la detección acumulada durante las dos rondas fue mayor entre los participantes con SOHi (15,47), lo que sugiere que una parte sustancial, pero no todos los hallazgos perdidos en la primera ronda debido al punto de corte de SOHi aumentado, se detectaron en la ronda siguiente.¹⁶ En un estudio observacional Danés, utilizando la base

de datos de su PDPCCR, se calcularon la sensibilidad y la especificidad para varios valores de corte basados en una gran cantidad de casos de CCR. Cuando la sensibilidad y la especificidad se ponderan por igual, el valor de corte óptimo de SOHi es de 45 ng Hb/ml (9 µg Hb/g heces), con lo que se necesitarían 24 colonoscopias para detectar un cáncer. Encontrando como valores de corte óptimos los de 80, 125, 175 y 350 ng Hb/ml, cuando para encontrar un CCR solo son aceptadas 19/16/14/ 10 colonoscopias respectivamente.¹⁷

La reciente pandemia por SARS-Cov2, provocó el cierre temporal de muchos PDPCCR a nivel mundial, limitando la actividad en las unidades de endoscopia a procedimientos urgentes o para estudios de pacientes con alta sospecha de cáncer gastrointestinal. En ese contexto nos planteamos el análisis de los factores asociados al hallazgo de una colonoscopia con resultado patológico, a fin de tratar de buscar un patrón predictivo que eventualmente nos permitiese la priorización de aquellos pacientes con mayor riesgo de endoscopia patológica dentro del programa, ya que actualmente los pacientes se van citando para la realización de la colonoscopia en base al orden de introducción en el programa, hallazgos que también serán de utilidad para el funcionamiento a largo plazo del PDPCCR de les Illes Balears.

Materiales y métodos

Descripción del PDPCCR de las Islas Baleares:

El programa de cribado de CCR (PDPCCR) de les Illes Balears se puso en marcha en enero del 2015 en los sectores sanitarios de Tramuntana (Mallorca), Menorca, Ibiza y Formentera.

La población diana objeto del programa son los hombres y mujeres de 50-69 años de edad, ambos inclusive, sin factores de riesgo conocidos, es decir, que va dirigido a la población de riesgo medio (personas sin antecedentes familiares ni personales para el desarrollo del cáncer colorrectal y que presentan como único factor de riesgo asociado la edad).

La prueba utilizada es el test de detección de sangre oculta en heces de tipo inmunológico cuantitativo (SOHi/OC-Sensor de PaLex), con el punto de corte en 100 ng/ml (20 µg/g de heces), que se realiza cada 2 años a los participantes con resultado anterior negativo, en caso de resultado positivo se ofrece a los participantes realización de colonoscopia.

Las colonoscopias fueron realizadas de acuerdo a los criterios de calidad recogidos en las diferentes guías.⁴

Diseño del estudio y población

Estudio observacional de tipo retrospectivo, utilizando una muestra de los datos obtenidos en las 2 primeras

rondas del PDPCCR de área de la Tramuntana (Hospital Comarcal de Inca), la primera va de Enero del 2015 a Diciembre del 2016, y la segunda va de Enero del 2017 a Diciembre del 2018.

Datos y definiciones:

Los datos a analizar fueron obtenidos de diversas fuentes, previa aceptación del proyecto por el comité de ética de nuestro hospital y teniendo en cuenta la ley de protección de datos, obtuvimos la información de los datos almacenados del PDPCCR en la Consellería, la medicación tomada por los pacientes se obtuvo del sistema informático de receta electrónica, los diagnósticos se obtuvieron de los datos registrados en la historia clínica hospitalaria y la historia clínica de atención primaria.

La base de datos consta de las siguientes variables:

- Identificador paciente anonimizado
 - Si ha tomado AAS
 - Si ha tomado Metformina
 - Si ha tomado Estatinas
 - Si ha tomado algún tipo de medicamento del grupo de los AINES
 - Si tiene algún diagnóstico de hipertensión arterial
 - Si tiene algún diagnóstico de obesidad
 - Si tiene algún diagnóstico de diabetes
 - Sexo: hombres y mujeres
 - Edad de los pacientes: Se han agrupado los pacientes en cohortes de grupos de edad, dando como resultado la división de la población diana en 3 grupos: entre 50 y 59 años, entre 60-64 años, entre 65-69 años.
 - Resultados de las colonoscopias:
 - Hallazgos: lesiones avanzadas y CCR
 - No Hallazgos: Colonoscopias normales o lesiones de bajo y moderado riesgo
- Para estratificar las lesiones no invasivas, nos basamos en las guías europeas del 2010.⁴ Dicha guía clasifican dichas lesiones de la siguiente manera:
- Bajo riesgo: 1-2 adenomas, y ambos pequeños (<10mm), y tubulares. y displasia de bajo grado
 - Riesgo medio: 3-4 adenomas, ó al menos un pólipo $\geq 10\text{mm}$ y <20mm, ó adenoma vellosos ó displasia de alto grado
 - Alto riesgo: ≥ 5 adenomas pequeños ó al menos uno $\geq 20\text{mm}$
- Valores cuantitativos de la SOHi: se agruparon en 4 grupos:
 - Grupo 1: <150 ng/ml
 - Grupo 2: 150-275 ng/ml
 - Grupo 3: 275-750 ng/ml
 - Grupo 4: >750 ng/ml

Análisis estadístico

El análisis estadístico de los datos se realizó con los paquetes estadísticos SPSS (versión 28) y Graphpad Prism (versión 9). La interacción entre factores fue determinada por la prueba exacta de Fisher o la prueba

de la chi-cuadrado. El nivel de significación se estableció para un valor de $p < 0.05$.

Resultados

Los resultados generales del PDPCCR de las Islas Baleares los publicamos en la revista Gastroenterología y Hepatología, órgano oficial de la Asociación Española de Gastroenterología a inicios de este año.¹⁸

En el presente estudio incluimos una muestra de 718 personas, de las 1.017 que finalmente se realizaron una colonoscopia en el Hospital de Inca en el marco de las 2 primeras rondas del PDPCCR, que fue la muestra en la que se pudieron recopilar todos los datos necesarios para el presente estudio.

Del total de los 718 participantes con SOHi positiva 412 eran hombres y 306 mujeres.

Figura 1: Distribución por sexo de la muestra.



Del total de los 718 pacientes que se realizaron la colonoscopia, presentaron Hallazgos 185, de los cuales 125 eran Hombres y 60 Mujeres

Figura 2: Distribución de hallazgos en la colonoscopia por sexo.



Al analizar la probabilidad de tener un hallazgo endoscópico de acuerdo al sexo (hombres vs mujeres), encontramos resultados estadísticamente significativos para el sexo masculino.

Figura 3: Porcentaje de resultados endoscópicos en cada sexo.



Tabla I: Asociación entre Hallazgos endoscópicos y sexo.

Test	Fisher's exact test		
P Value	<0,0001		
Odds ratio	2,525	95% CI (1,790 to 3,549)	
	Hallazgo	No hallazgo	TOTAL
Hombres	125	287	412
Mujeres	60	246	306
Total	185	533	718

Al analizar la probabilidad de tener un hallazgo endoscópico de acuerdo a la edad, teniendo en cuenta las cohortes de edad utilizadas, obtuvimos resultados estadísticamente significativos para el total de la muestras y para el grupo de las mujeres.

Tabla II: Test Chi-square: probabilidad de hallazgos endoscópico de acuerdo a la edad.

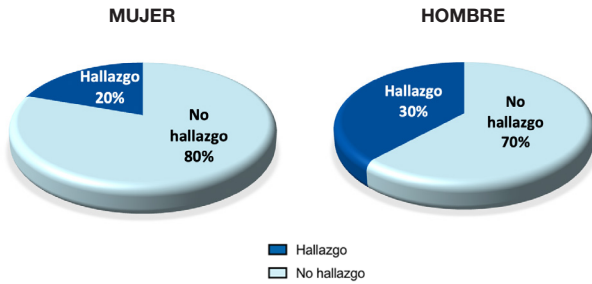
	Total	Hombres	Mujeres
Chi-square, df	12,90, 2	4,035, 2	10,80, 2
P value	0,0016	0,1330	0,0045

Tabla III: Porcentajes de hallazgos endoscópicos respecto a edad y sexo.

HALLAZGOS	TOTAL		HOMBRES		MUJERES	
	NO	SI	NO	SI	NO	SI
65-69 años	62%	38%	56%	44%	70%	30%
60-64 años	70%	30%	62%	38%	83%	17%
50-59 años	80%	20%	71%	29%	89%	11%

Al analizar la probabilidad de tener Hallazgos en la colonoscopia respecto a los valores cuantitativos de SOHi, teniendo en cuenta las cohortes utilizadas para los valores de SOHi, obtuvimos resultados estadísticamente significativos para el total de la muestra y para el grupo de los hombres.

Tabla IV: Tabla cruzada de resultados endoscópicos vs grupos de valores cuantitativos de SOHi.

		1,00	2,00	3,00	4,00	TOTAL
NO HALLAZGOS	Recuento	140	137	124	100	501
	% NO hallazgos	27,9%	27,3%	24,8%	20,0%	100%
	% SOH	80,0%	74,9%	68,9%	55,6%	69,8%
	% del total	19,5%	19,1%	17,3%	13,9%	69,8%
HALLAZGOS	Recuento	35	46	56	80	217
	% hallazgos	16,1%	21,2%	25,8%	36,9%	100%
	% SOH	20,0%	25,1%	31,1%	44,4%	30,2%
	% del total	4,9%	6,4%	7,8%	11,1%	30,2%
TOTAL	Recuento	175	183	180	180	718
	% hallazgos	24,4%	25,5%	25,1%	25,1%	100,0%
	% SOH	100,0%	100,0%	100,0%	100,0%	100,0%
	% del total	24,4%	25,5%	25,1%	25,1%	100,0%

Tabla V: Test Chi-square: probabilidad de hallazgos endoscópicos respecto a valores de SOHi.

	Total	Hombres	Mujeres
Chi-square, df	28,25, 3	20,07, 3	4,991,3
P value	<0,0001	0,0002	0,1724

Tabla VI: Porcentajes de hallazgos en la colonoscopia de acuerdo a los grupos cuantitativos de SOHi.

HALLAZGOS	TOTAL		HOMBRES		MUJERES	
	NO	SI	NO	SI	NO	SI
SOHi <150	80%	20%	72%	28%	87%	13%
150-275	75%	25%	70%	30%	80%	20%
275-750	69%	31%	63%	37%	78%	22%
>750	56%	44%	46%	54%	73%	27%

Figura 4: Gráfico de los Porcentajes de hallazgos endoscópicos respecto a edad y sexo.



Figura 5: Porcentajes de hallazgos en la colonoscopia de acuerdo a los grupos cuantitativos de SOHi.



Al analizar la asociación entre la toma de AINES y los hallazgos endoscópicos en nuestra muestra, encontramos asociación estadísticamente significativa como factor protector de la toma en el total de la muestra y en las mujeres

Figura 6: Porcentajes de hallazgos en la colonoscopia de acuerdo a la toma de AINES.

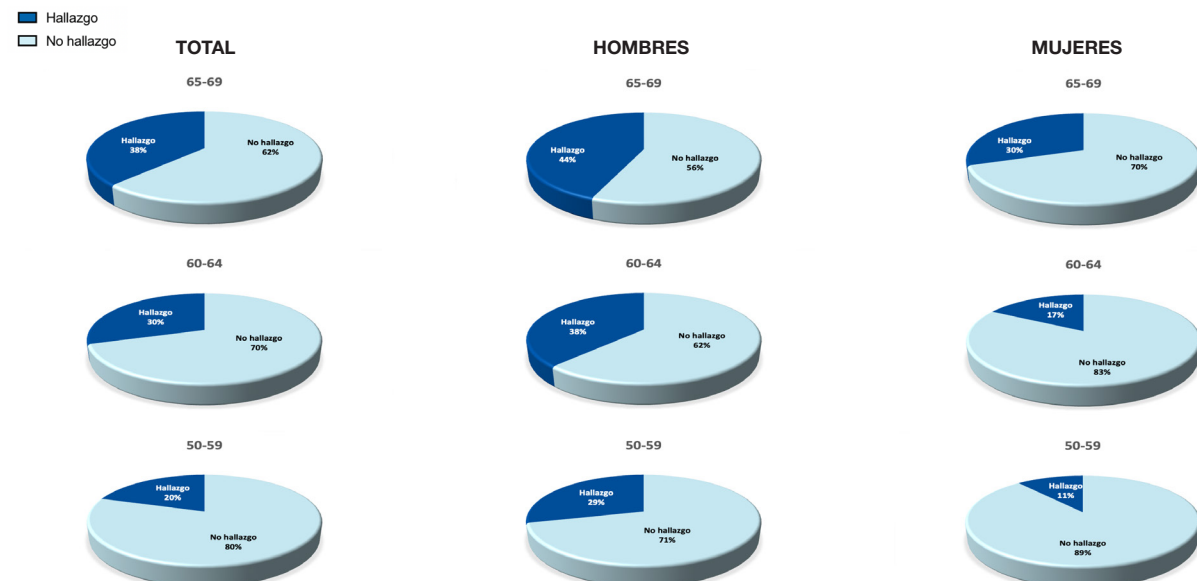
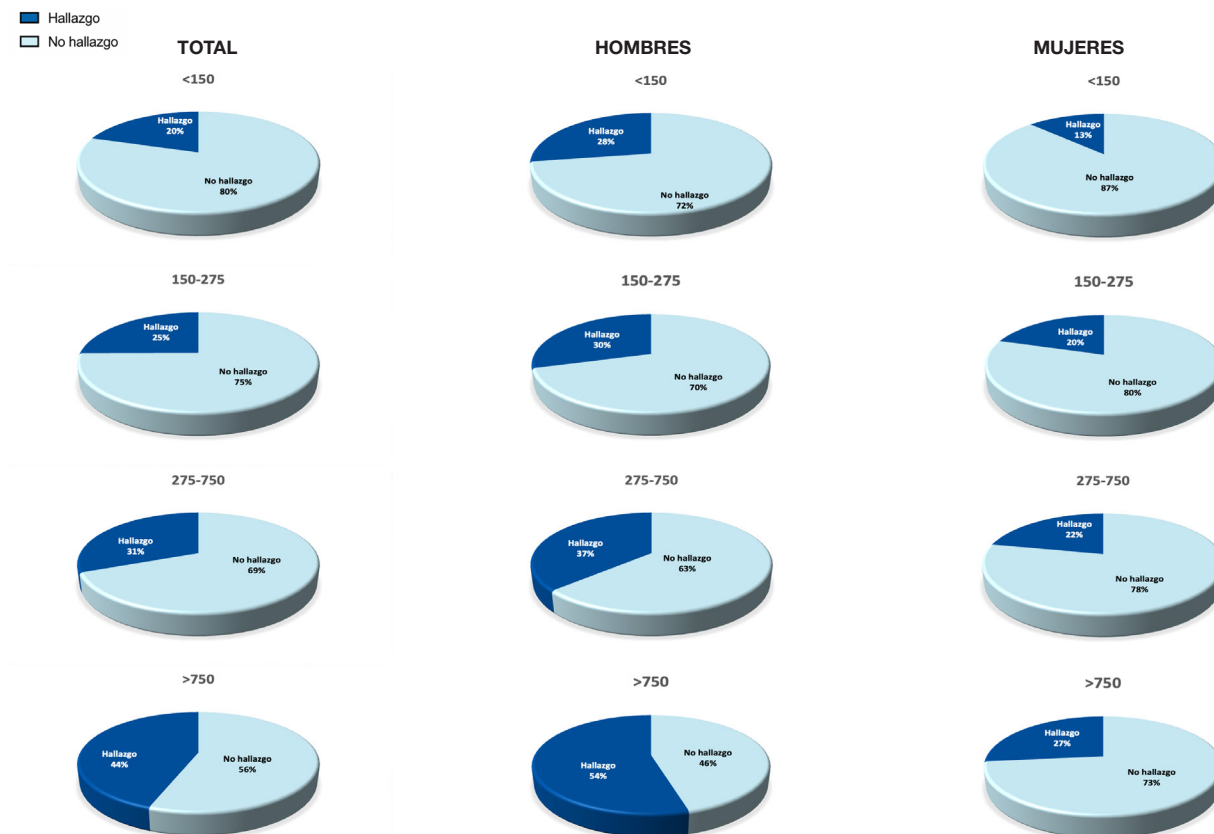

Tabla VII: Distribución de la toma de AINES y porcentajes de hallazgos en la colonoscopia.

TOTAL DE LA MUESTRA			
	Hallazgo	No hallazgo	Total
No tomaban AINES (%)	161 (33%)	325 (67%)	486 (100%)
Tomaban AINES(%)	56 (24%)	176 (76%)	232 (100%)
Total	217	501	718

HOMBRES			
	Hallazgo	No hallazgo	Total
No tomaban AINES	115 (39%)	181 (61%)	296 (100%)
Tomaban AINES	42 (36%)	74 (64%)	116 (100%)
Total	157	255	412

MUJERES			
	Hallazgo	No hallazgo	Total
No tomaban AINES	46(24%)	144(76%)	190(100%)
Tomaban AINES	14(12%)	102(88%)	116(100%)
Total	60	246	306

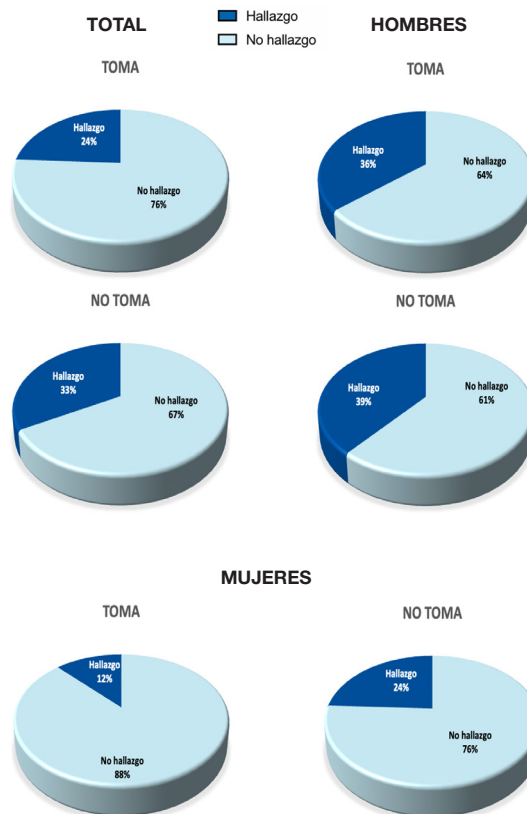
Tabla VIII: Fisher's exact test: probabilidad de hallazgos endoscópicos respecto a la toma de AINES.

AINES	Total	Hombres	Mujeres
Odds ratio	0,64	1,12	0,43
P Value	0,0085	0,3517	0,0062

Tabla X: Fisher's exact test: probabilidad de hallazgos endoscópicos respecto a la toma de AAS.

AAS	Total	Hombres	Mujeres
Odds ratio	2,15	1,90	1,69
P Value	0,0046	0,0311	0,2858

Al analizar la asociación entre la toma de AAS y los hallazgos endoscópicos en nuestra muestra, encontramos asociación estadísticamente significativa como factor protector de la toma en el total de la muestra y en los hombres

Al analizar la asociación entre la obesidad, la Hipertensión arterial, la Diabetes Mellitus, la toma de metformina y la toma de estatinas, no encontramos asociación estadísticamente significativa en el total de la muestra y ni por sexo.

Tabla IX: Distribución de la toma de AAS y porcentajes de hallazgos en la colonoscopia.

TOTAL DE LA MUESTRA			
	No hallazgo	Hallazgo	Total
No Toma de AAS	470 (71%)	190 (29%)	660 (100%)
Toma de AAS	31 (53%)	27 (47%)	58 (100%)
Total	501	217	718

HOMBRES			
	No hallazgo	Hallazgo	Total
No Toma de AAS	234 (64%)	134 (36%)	368 (100%)
Toma de AAS	21 (48%)	23 (52%)	44 (100%)
Total	255	157	412

MUJERES			
	No hallazgo	Hallazgo	Total
No Toma de AAS	236 (81%)	56 (19%)	292 (100%)
Toma de AAS	10 (71%)	4 (29%)	14 (100%)
Total	246	60	306

Tabla XI: Fisher's exact test: probabilidad de hallazgos endoscópicos respecto a diversos factores.

	TOTAL	HOMBRES	MUJERES
Odds ratio Obesidad	1,12	1,47	1,03
P Value	0,4451		
Odds ratio Hipertensión	1,11	1,30	1,60
P Value	0,3414		
Odds ratio DM	1,17	1,14	1,84
P Value	0,3527		
Odds ratio metformina	1,48	1,12	2,14
P Value	0,0534		
Odds ratio Estatinas	0,77	0,76	0,81
P Value	0,0750		

Figura 7: Porcentajes de hallazgos en la colonoscopia de acuerdo a la toma de ASS.

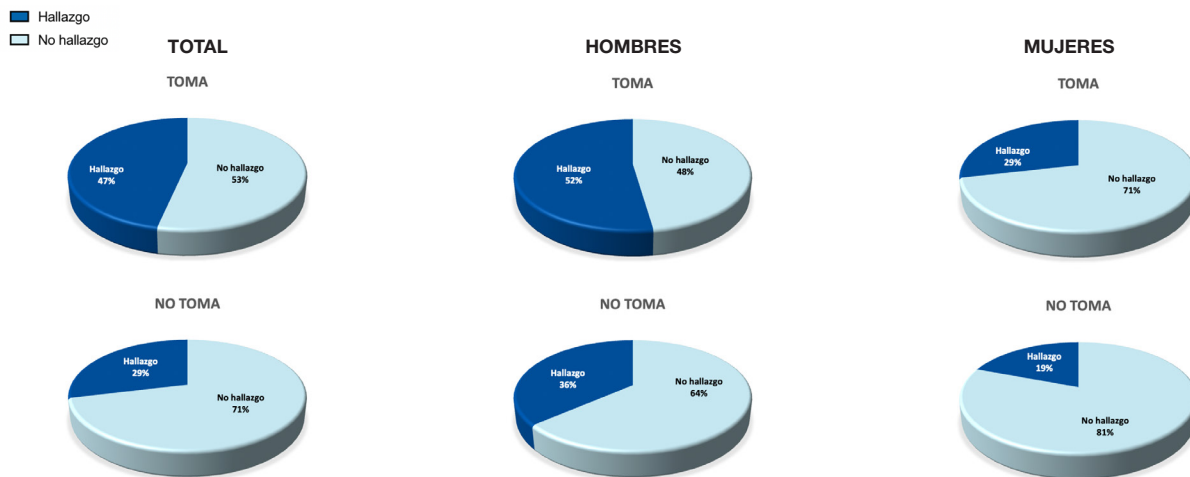

Discusión

La distribución de la población por edad y sexo es un factor que influye en el impacto de los PDPCCR ya que la incidencia y mortalidad por CCR es menor en mujeres que en hombres, y tiende a aumentar con la edad. Varios estudios muestran que los valores cuantitativos de SOHi en heces es diferente en hombres y mujeres, esto sumado a las diferencias encontradas en los hallazgos

endoscópicos de los PDPCCR por edad y sexo, hace que varios autores sugieran modificar los puntos de corte para SOHi, teniendo en cuenta dichas variables.¹⁹⁻²¹

En España los PDPCCR, se desarrollan en cada Comunidad Autónoma siguiendo las directrices del Ministerios de Sanidad, utilizando todos el test de SOHi

como prueba de cribado con un valor de corte de 20 µg/g heces (100 ng/ml), habiéndose demostrado en un estudio español que el cribado basado en SOHi se ha asociado a reducciones en la mortalidad por CCR al séptimo año después de la implementación del mismo. A pesar de las diferencias de género previamente documentadas en el rendimiento diagnóstico de SOHi, las reducciones relativas en la mortalidad fueron similares tanto para hombres como para mujeres con un solo valor de corte.²²

En nuestro estudio encontramos asociación entre los hallazgos endoscópicos, lesiones avanzadas y CCR, a favor del sexo masculino, con evidencia de más hallazgos en el grupo de los hombres; asimismo encontramos asociación con respecto a la edad, encontrando en la muestra total más riesgos de hallazgos endoscópicos a edades más avanzadas, hecho que destacó en el sexo femenino al hacer el análisis por sexo.

Cuando vemos las gráficas de los porcentajes de hallazgos endoscópicos podemos apreciar mejor dichos resultados (**Figura 4**), encontrando en los hombres, en los diferentes grupos de edad, un porcentaje de hallazgos cercano entre los grupos, mientras que en las mujeres vemos el aumento más marcado de dicho porcentaje en el grupo de entre 65 y 69 años.

Cuando analizamos la probabilidad de tener Hallazgos en la colonoscopia con respecto a los valores cuantitativos de SOHi, teniendo en cuenta las cohortes utilizadas para los diferentes valores de SOHi, encontramos que a más valor cuantitativo de SOHi más probabilidad de hallazgos endoscópicos, lo que destaca en el grupo de los hombres. Nuevamente cuando vemos las gráficas de los porcentajes de hallazgos endoscópicos para este análisis (**Figura 5**), podemos apreciar mejor dichos resultados, evidenciando un porcentaje cercano de hallazgos en las diferentes cohortes en las mujeres, mientras que en los hombres la diferencia de dichos porcentajes es mucho más marcada.

En un estudio Neerlandés, con el objetivo de calcular puntos de corte de SOHi individualizados en función de la edad y el sexo, invitaron a participar a 1.112 personas con riesgo medio de CCR, entre los 50-75 años, fueron invitados a realización de colonoscopia previa SOHi. Se construyó un modelo de regresión logística para calcular el riesgo de tener una neoplasia avanzada en la colonoscopia utilizando la edad, el sexo y la concentración de SOHi como variables. En un total de 101 de 1.112 participantes, se detectó neoplasia avanzada (NA) en la colonoscopia. Se seleccionó un umbral de riesgo que produciría una especificidad del 96,9% en el grupo de estudio, igualando la especificidad de SOHi con punto de corte de 20 µg Hb/g de heces. En este umbral, las concentraciones de corte de SOHi ajustadas por edad y sexo oscilaron entre 36,9 µg Hb/g de heces para mujeres de 50 años y 9,5 µg de Hb/g de heces para hombres

de 75 años. En este nivel de especificidad, el modelo basado en el riesgo alcanzó una sensibilidad para del 28,7 % frente al 27,7% para SOHi sola.

Dichos resultados sugieren que el uso de un umbral de riesgo ajustado por edad y sexo, en lugar de un punto de corte uniforme de SOHi para invitar a los participantes a una colonoscopia, garantiza que todos tengan un riesgo comparable de NA antes de la colonoscopia y puede mejorar la detección de lesiones, aunque la magnitud absoluta del aumento probablemente sea limitada.²⁰

En un estudio español de cohortes retrospectivo multicéntrico de los participantes en programas de cribado de CCR con SOHi entre 2006 y 2012 de algunas comunidades autónomas de España, se analizaron un total de 545.505 participantes, con el objetivo de identificar puntos de corte específicos para grupos edad y sexo. Los resultados muestran que la concentración de Hb fue mayor en cáncer colorrectal (promedio = 179,6 µg/g) vs falsos positivos (promedio = 55,2 µg/g) y verdaderos negativos (promedio = 0 µg/g), así como en el grupo de los hombres (promedio = 166,2 µg/g) frente a mujeres (promedio = 140,2 µg/g) con cáncer colorrectal. Los valores de corte óptimos para mujeres fueron 18,3 µg/g (50-59 años) y 14,6 µg/g (60-69 años), y 16,8 µg/g (50-59 años) y 19,9 µg/g (60-69 años) para hombres. Con dichos resultados, concluyeron entonces que el valor de corte óptimo de SOHi varía según el sexo y los grupos de edad, y el uso de un valor de corte óptimo para cada grupo mejora la sensibilidad, lo que conlleva a un incremento de falsos positivos.²¹

En la actualidad, la obesidad es un problema de salud con una alta prevalencia y múltiples repercusiones orgánicas, siendo una patología ligada al síndrome metabólico, el cual se define por un conjunto de factores de riesgo cardiometabólico dentro de los cuales se incluye la antes mencionada obesidad y muchos otros factores como la hipertensión, la dislipidemia, hiperglucemia y los estados protrombóticos y proinflamatorios. Una revisión sistémica y metaanálisis evaluó la asociación del síndrome metabólico y sus componentes con la incidencia y mortalidad del CCR (17 estudios y 11.462 casos de cáncer). El síndrome metabólico se asoció con un mayor riesgo de incidencia y mortalidad del CCR en ambos sexos. Las estimaciones de riesgo para cualquier factor único del síndrome fueron significativas para valores más altos de IMC/perímetro de cintura, hiperglicemia y presión arterial alta, siendo la hiperglicemia y/o un IMC/cintura los principales factores que explicaron la mayor parte del riesgo asociado con el síndrome metabólico.²³

Existen evidencias que sugieren que la diabetes mellitus estaría asociada con un riesgo elevado de desarrollar CCR, incluso cuando se incluyen estudios ajustados a factores añadidos como el tabaquismo, la obesidad y

la actividad física.²⁴ En un metaanálisis se estimó que el riesgo de cáncer de colon entre personas diabéticas era aproximadamente un 37% más alto que en los no diabéticos.²⁵

El interés en algunos fármacos como el AAS, los AINES, (AAS), la metformina, y estatinas, surgió de estudios en los que la prescripción de estos fármacos solos o en combinación con otros medicamentos han mostrado disminución del riesgo de CCR, si bien existen estudios con resultados contradictorios.¹¹⁻¹³

En el año 2016, la US Preventive Services Task Force actualizó la revisión sistémica la revisión sistémica en la que se analiza el riesgo de incidencia y mortalidad por CCR y el uso de AAS en el contexto de ensayo clínico de prevención primaria y secundaria de enfermedad cardiovascular. En relación con la mortalidad el AAS se asoció con una reducción de riesgo acumulativo de mortalidad por CCR a largo plazo de aproximadamente el 33%.

La incidencia de CCR se redujo en los pacientes asignados a tratamiento con AAS tras 10-19 años de tratamiento.²⁶

En el contexto de pacientes con neoplasia colorrectal previa, una revisión sistémica, realizó un metaanálisis de red bayesiana y una clasificación relativa de combinaciones de quimioprevención con una superficie bajo las probabilidades de clasificación acumulada (SUCRA) que oscilaba entre 1, indicando que el tratamiento tiene una alta probabilidad de ser mejor, y 0, indicando que el tratamiento tiene una alta probabilidad de ser peor. En comparación con el placebo, los AINES sin incluir el AAS, se clasificaron como los mejores para prevenir la neoplasia metacrónica avanzada, seguido del AAS a dosis baja. El AAS a dosis bajas, sin embargo, fue clasificado como el más seguro entre los agentes de quimioprevención, mientras que los AINES sin incluir el AAS, fueron clasificados de menor seguridad. Tomando en conjunto los resultados, se sugiere que entre los individuos con neoplasia colorrectal previa los AINES sin incluir el AAS, son los agentes más eficaces para la prevención de la neoplasia metacrónica avanzada, mientras que el AAS a dosis baja tiene el perfil de beneficio-riesgo más favorable.²⁷

Diversos metaanálisis de estudios observacionales sugieren que el uso de metformina en pacientes diabéticos tipo 2 se asocia a reducción de riesgo de adenomas y de CCR.

Un metaanálisis mostró que el uso de metformina reduce el riesgo de adenomas. El análisis por subgrupos mostró una tendencia a la disminución del riesgo de adenoma en la población de alto riesgo por antecedentes de neoplasia colorrectal. A pesar de estos hallazgos, se necesitan estudios controlados prospectivos para

evaluar rigurosamente la eficacia de la metformina como agente preventivo.²⁸

Aunque se ha sugerido que las estatinas podrían disponer de un efecto protector contra varios cánceres, incluyendo el CCR, en varios estudios observacionales, los resultados son contradictorios y no concluyentes.²⁹

Al analizar la asociación entre los posibles factores asociados a hallazgos endoscópicos, de riesgo o protectores, encontramos como posibles factores protectores, en el total de la muestra y por sexo, a los AINES en las mujeres y al AAS en los hombres.

Sin embargo no encontramos asociación entre la obesidad, la Hipertensión arterial, la Diabetes Mellitus, la toma de metformina y la toma de estatinas, ni en el grupo total ni en el análisis por sexo.

Creemos que la falta de asociación de algunos factores con los hallazgos, podría ser consecuencia de dos situaciones, lo primero es el tipo de estudio, ya que es un estudio retrospectivo, por lo que los datos recopilados son los que encontramos registrados en las fuentes de datos previamente descritas, pudiendo existir posibles errores o falta de información en el registro de los mismos; en segundo lugar es el tamaño de la muestra, ya que al tratarse de una muestra pequeña, esta podría no ser representativa.

Conclusiones

Las conclusiones son positivas, dado que hemos conseguido replicar los resultados de otros estudios respecto al riesgo de hallazgos endoscópicos en relación con la edad, el sexo y los valores cuantitativos de SOHi, así como la asociación de efecto protector de la toma de AINES y AAS con dichos hallazgos.

Somos conscientes de la importancia, para conseguir modelos con mayor precisión, de la necesidad de recolección prospectiva, sistemática y detallada de los datos de todos los pacientes incluidos, lo que conllevará no solo a la optimización en el registro de los datos, sino también a un aumento del tamaño muestral.

Los resultados de nuestro estudio fortalecen al PDPCCR de les Illes Balears, pero sobre todo nos servirán de base para obtener resultados más sólidos en las próximas rondas del programa, que nos ayudaran a desarrollar modelos de riesgo más precisos, lo que nos permitirá priorizar las listas de espera para brindar detección y tratamiento precoz, aumentando la eficacia de nuestro programa.

Conflicto de intereses

Los autores declaran no tener conflicto de intereses respecto a la presente investigación.

Bibliografía

- Galcerán J, Ameijide A, Carulla M. Estimaciones de la incidencia y la supervivencia del cáncer en España y su situación en Europa. REDECAN. 2014.
- Sung H, Ferlay J, Siegel RL, Laversanne M, Soerjomataram I, Jemal A, et al. Global Cancer Statistics 2020: GLOBOCAN Estimates of Incidence and Mortality Worldwide for 36 Cancers in 185 Countries. *Ca Cancer J Clin* (2021) 71(3):209–49. doi: 10.3322/caac.21660
- Lin JS, Perdue LA, Henrikson NB, Bean SI, Blasi PR. Screening for Colorectal Cancer: Updated Evidence Report and Systematic Review for the US Preventive Services Task Force. *JAMA*. 2021 May 18;325(19):1978–1998. doi: 10.1001/jama.2021.4417.
- European Commission. European guidelines for quality assurance in colorectal cancer screening and diagnosis. Luxembourg: International Agency for Research on Cancer (IARC); 2010.
- Winawer SJ, Zauber AG, Ho MN, O'Brien MJ, Gottlieb LS, Sternberg SS, et al. Prevention of colorectal cancer by colonoscopic polypectomy. The National Polyp Study Workgroup. *N Engl J Med*. 1993;329:1977–81.
- Quintero E, Castells A, Bujanda L, Cubiella J, Salas D, Lanás Á, et al. Colonoscopy versus fecal immunochemical testing in colorectal-cancer screening. *N Engl J Med*. 2012 Feb 23;366(8):697–706. doi: 10.1056/NEJMoa1108895.
- Soltani G, Poursheikhani A, Yassi M, Hayatbakhsh A, Kerachian M, Kerachian MA. Obesity, Diabetes and the Risk of Colorectal Adenoma and Cancer. *BMC Endocr Disord* (2019) 19(1):113. doi: 10.1186/s12902-019-0444-6
- Pelucchi C, Negri E, Talamini R, Levi F, Giacosa A, Crispo A, et al. Metabolic Syndrome Is Associated With Colorectal Cancer in Men. *Eur J Cancer* (2010) 46(10):1866–72. doi: 10.1016/j.ejca.2010.03.010
- Elangovan A, Skeans J, Landsman M, Ali SMJ, Elangovan AG, Kaelber DC, et al. Colorectal Cancer, Age, and Obesity-Related Comorbidities: A Large Database Study. *Digest Dis Sci* (2021) 66(9):3156–63. doi: 10.1007/s10620-020-06602-x
- Kim M, Park K. Dietary Fat Intake and Risk of Colorectal Cancer: A Systematic Review and Meta-Analysis of Prospective Studies. *Nutrients* (2018) 10(12):1963. doi: 10.3390/nu10121963
- Umezawa S, Higurashi T, Komiya Y, Arimoto J, Horita N, Kaneko T, Iwasaki M, Nakagama H, Nakajima A. Chemoprevention of colorectal cancer: Past, present, and future. *Cancer Sci*. 2019 Oct;110(10):3018–3026. doi: 10.1111/cas.14149.
- Katona BW, Weiss JM. Chemoprevention of Colorectal Cancer. *Gastroenterology*. 2020;158(2):368–388. doi:10.1053/j.gastro.2019.06.047
- Chapelle N, Martel M, Toes-Zoutendijk E, Barkun AN, Bardou M. Recent advances in clinical practice: colorectal cancer chemoprevention in the average-risk population. *Gut*. 2020;69(12):2244–2255. doi:10.1136/gutjnl-2020-320990
- Reyes Moreno J, Trelles Guzmán M, Florido García M, Ortega Moya SP, Iyo- Miyashiro E. Resultados del programa de diagnóstico precoz de cáncer de colon y recto de les Illes Balears en el Hospital Comarcal de Inca en las dos primeras rondas de su desarrollo en relación a la actividad endoscópica: enero 2015- diciembre 2018. *Medicina balear*, ISSN 2255-0569, Vol 35, Nº 1, 2020, pages 26-36. January 2020.
- Aznar-Gimeno R, Carrera-Lasfuentes P, Del-Hoyo-Alonso R, Doblaré M, Lanás Á. Evidence-Based Selection on the Appropriate FIT Cut-Off Point in CRC Screening Programs in the COVID Pandemic. *Front Med (Lausanne)*. 2021 Jul 27;8:712040. doi: 10.3389/fmed.2021.712040.
- Kooyker AI, Toes-Zoutendijk E, Opstal-van Winden AWJ, Spaander MCW, Buskermolen M, van Vuuren HJ, et al. The second round of the Dutch colorectal cancer screening program: Impact of an increased fecal immunochemical test cut-off level on yield of screening. *International Journal of Cancer*. 2020;147(4):1098. doi:10.1002/ijc.32839
- Njor SH, Andersen B, Friis-Hansen L, de Haas N, Linnemann D, Nørgaard H, et al. The optimal cut-off value in fit-based colorectal cancer screening: An observational study. *Cancer Med*. 2021 Mar;10(5):1872–1879. doi: 10.1002/cam4.3761.
- Trelles Guzmán MG, Novella Duran MT, Heredia Centeno ML, Florido García M, Sanchez-Contador Escudero MDC, Iyo Miyashiro EY, et al. Result of the first two rounds of the colorectal cancer screening program in the Balearic Islands (Spain). *Gastroenterología y hepatología*. 2022;45 Suppl 1:55–57. doi:10.1016/j.gastrohep.2020.12.001
- Pellat A, Deyra J, Husson M, Benamouzig R, Coriat R, Chaussade S. Colorectal cancer screening programme: is the French faecal immunological test (FIT) threshold optimal? *Therap Adv Gastroenterol*. 2021 May 7;14:17562848211009716. doi: 10.1177/17562848211009716.
- Kortlever TL, van der Vlugt M, Dekker E, Bossuyt PMM. Individualized faecal immunochemical test cut-off based on age and sex in colorectal cancer screening. *Preventive Medicine Reports*. 2021;23. doi:10.1016/j.pmedr.2021.101447
- Vanadocha-Espi M, Ibáñez J, Molina-Barceló A, Valverde-Roig MJ, Nolasco A, Pérez-Riquelme F, et al. Optimal cut-off value for detecting colorectal cancer with fecal immunochemical tests according to age and sex. *PLoS One*. 2021 Jul 16;16(7):e0254021. doi: 10.1371/journal.pone.0254021.
- Keys MT, Serra-Burriel M, Martínez-Lizaga N, Pellisé M, Balaguer F, Sánchez A, Bernal-Delgado E, Castells A. Population-based organized screening by faecal immunochemical testing and colorectal cancer mortality: a natural experiment. *Int J Epidemiol*. 2021 Mar 3;50(1):143–155. doi: 10.1093/ije/dyaa166.
- Espósito K, Chiodini P, Colao A, Lenzi A, Giugliano D. Metabolic syndrome and risk of cancer: a systematic review and meta-analysis. *Diabetes Care*. 2012 Nov;35(11):2402–11. doi: 10.2337/dc12-0336.
- Yuhara H, Steinmaus C, Cohen SE, Corley DA, Tei Y, Buffler PA. Is diabetes mellitus an independent risk factor for colon cancer and rectal cancer? *Am J Gastroenterol*. 2011 Nov;106(11):1911–21; quiz 1922. doi: 10.1038/ajg.2011.301.
- Luo S, Li JY, Zhao LN, Yu T, Zhong W, Xia ZS, Shan TD, Ouyang H, Yang HS, Chen QK. Diabetes mellitus increases the risk of colorectal neoplasia: An updated meta-analysis. *Clin Res Hepatol Gastroenterol*. 2016 Feb;40(1):110–23. doi: 10.1016/j.clinre.2015.05.021.
- Chubak J, Whitlock EP, Williams SB, Kamineni A, Burda BU, Buist DS, Anderson ML. Aspirin for the Prevention of Cancer Incidence and Mortality: Systematic Evidence Reviews for the U.S. Preventive Services Task Force. *Ann Intern Med*. 2016 Jun 21;164(12):814–25. doi: 10.7326/M15-2117.
- Dulai PS, Singh S, Marquez E, Khera R, Prokop LJ, Limburg PJ, Gupta S, Murad MH. Chemoprevention of colorectal cancer in individuals with previous colorectal neoplasia: systematic review and network meta-analysis. *BMJ*. 2016 Dec 5;355:i6188. doi: 10.1136/bmj.i6188.
- Jung YS, Park CH, Eun CS, Park DI, Han DS. Metformin use and the risk of colorectal adenoma: A systematic review and meta-analysis. *J Gastroenterol Hepatol*. 2017 May;32(5):957–965. doi: 10.1111/jgh.13639.
- Bonovas S, Filioussi K, Flordellis CS, Sitaras NM. Statins and the risk of colorectal cancer: a meta-analysis of 18 studies involving more than 1.5 million patients. *J Clin Oncol*. 2007 Aug 10;25(23):3462–8. doi: 10.1200/JCO.2007.10.8936.

An epidemiological study of the prevalence and associated risk factors of goiter among adults in the southern part of Albania

Estudio epidemiológico sobre la prevalencia y los factores de riesgo asociados al bocio en adultos del sur de Albania

Igli Kokalari¹ , Erjona Abazaj² , Ela Ali² 

1. Surgeon at Regional Hospital of Gjirokastra, Albania

2. Institute of Public Health, Tirana, Albania

Corresponding author

Erjona Abazaj

E-mail: abazajerjona@gmail.com

Received: 14 - I - 2023

Accepted: 15 - II - 2023

doi: 10.3306/AJHS.2023.38.03.115

Abstract

Introduction: In developing countries such as Albania, goiter is a major public health problem. Although the morbidity and mortality of thyroid surgery have decreased markedly, serious complications may still occur. The study aimed to evaluate the prevalence and associated factors of goiter in women in Gjirokastra city, situated in south Albania.

Methods: This descriptive cross-sectional retrospective study was conducted from January 2009 to December 2018. The data of 325 women suspected of goiter were collected. The epidemiological data such as demographic data, family history, smoking, alcohol consumption, body mass index, menstrual status, salt consumption, and also metabolic syndrome were analyzed by SPSS version 20.0. The logistic regression analysis was applied to assess the risk factors and the relationship between variables. P-values less than 0.05 were considered statistically significant.

Results: The prevalence of goiter was 35.7% (116/325) (95% CI, 31.01 to 39.4%). The mean age was 41.32±10.05 with a minimum and maximum age of 20 to 71. The most affected age resulted in 41-50 years old with 41% (95% CI, 37.4 to 45.8%). The finding showed that age, family history, BMI, and menstrual status had a significant relationship with goiter with a p-value <0.05. Likewise, our study demonstrated metabolic syndrome to be a strong predictor of goiter.

Conclusions: The prevalence of goiter was relatively high among women. Having a family history and being 41-50 years old increased the risk of goiter. The findings data suggest the need for special attention for females of advanced age, on menopause, obesity, and metabolic syndrome. They should be examined by physicians and screened with imaging tests and laboratories test for goiter.

Key words: prevalence, goiter, women, epidemiological, risk factors.

Resumen

Introducción: En los países en vías de desarrollo, como Albania, el bocio es un importante problema de salud pública. Aunque la morbilidad y la mortalidad de la cirugía tiroidea han disminuido notablemente, todavía pueden producirse complicaciones graves. El estudio tenía como objetivo evaluar la prevalencia y los factores asociados del bocio en las mujeres de la ciudad de Gjirokastra, situada en el sur de Albania.

Métodos: Este estudio descriptivo transversal retrospectivo se realizó desde enero de 2009 hasta diciembre de 2018. Se recogieron los datos de 325 mujeres con sospecha de bocio. Los datos epidemiológicos como los datos demográficos, los antecedentes familiares, el tabaquismo, el consumo de alcohol, el índice de masa corporal, el estado menstrual, el consumo de sal y también el síndrome metabólico fueron analizados por el SPSS versión 20.0. Se aplicó el análisis de regresión logística para evaluar los factores de riesgo y la relación entre las variables. Se consideraron estadísticamente significativos los valores P inferiores a 0,05.

Resultados: La prevalencia de bocio fue del 35,7% (116/325) (IC 95%, 31,01 a 39,4%). La edad media fue de 41,32± 10,05 con una edad mínima y máxima de 20 a 71 años. La edad más afectada resultó ser la de 41-50 años con un 41% (IC 95%, 37,4 a 45,8%). El hallazgo mostró que la edad, los antecedentes familiares, el IMC y el estado menstrual tenían una relación significativa con el bocio con un valor p <0,05. Asimismo, nuestro estudio demostró que el síndrome metabólico es un fuerte predictor del bocio.

Conclusiones: La prevalencia del bocio fue relativamente alta entre las mujeres. Tener antecedentes familiares y tener entre 41 y 50 años aumentó el riesgo de bocio. Los datos de los hallazgos sugieren la necesidad de prestar una atención especial a las mujeres de edad avanzada, con menopausia, obesidad y síndrome metabólico. Deberían ser examinadas por los médicos y sometidas a pruebas de imagen y de laboratorio para detectar el bocio.

Palabras clave: prevalencia, bocio, mujeres, epidemiológico, factores de riesgo.

Introduction

Goiter is a condition characterized by enlargement of the thyroid gland over time¹. It is a major public health problem, in several areas of the world², which can be due to several causes. More than one-tenth of the world population is to some degree affected by goiter and most of these harbor nodules. Globally, the total goiter prevalence in the general population is estimated to be 15.8%, varying between 4.7% in America to 28.3% in Africa³. The large differences in thyroid disease prevalence between populations may be caused by genetic and environmental factors⁴. The most common worldwide (over 90%) is a simple goiter due to an iodine deficiency in the diet. Hyperthyroidism can also lead to goiter as a result of an over-secretion of TSH and a build-up of thyroid tissue. Other causes of goiter are less common and can involve tumors or autoimmune reactions⁵. Most thyroid nodules and goiters do not present any symptoms; however, they can be associated with other disorders, including endocrine dysfunction, impaired body composition, autoimmune thyroid disease, and various metabolic disorders⁶. Coordinating basal metabolic rate and thermogenesis is key for thyroid hormones^{7,8}. Goiter can be detected clinically by palpation and physical examination when there are insufficient amounts of iodine⁹. The prevalence of ultrasound-detectable nodules ranges from 19% to 67% and only 4-7% of thyroid nodules detected by ultrasound are palpable¹⁰. Women are more likely to have thyroid disorders, including goiter and thyroid nodules, although some authors could not confirm any gender-related associations^{11,12}. In some research was reported that metabolic syndrome (MetS) and its related components, including obesity, insulin resistance (IR), hypertension, dyslipidemia, and impaired glucose metabolism, are associated with morphological abnormalities of the thyroid and may contribute to increased thyroid volume as well as nodule prevalence^{7,13}. Additionally, other studies highlighted the importance of hyperinsulinemia/insulin resistance, the central features of MetS, in thyroid cell proliferation, which manifested as increased thyroid volume and nodule^{14,15}. The Association of thyroid functional and morphological changes with individual risk factors, especially with smoking habits, has been investigated previously. Some authors have found a significant relationship between smoking and increased thyroid volume, a prevalence of goiter, or thyroid multinodularity in areas with iodine deficiency¹⁶. The study aimed to evaluate the prevalence and associated factors of goiter in women in Gjirokastra city, situated in south Albania.

Methods

This descriptive cross-sectional retrospective study was conducted from January 2009 to December 2018. The study comprised 325 suspected goiters patients who obtained the service from the specialist endocrinologist and surgeon in the city of Gjirokastra.

In this study, we included patients of both sexes that had files with complete data. While excluded from the study were subjects with inadequate specimens for diagnosis, incomplete data, or data acquisition errors. The clinical history of each patient was taken throughout the examination. The information regarding the general socio-demographic data, which includes, age, gender, residential area, marital status, occupation, education level, economic status, and family history was collected from the record files of each patient. The epidemiological information regarding female menstrual status, salt consumption, and also metabolic syndrome alcohol, smoking, and physical was collected also. Furthermore, the clinical manifestations, goiter physical appearance, presenting complaints, comorbidities, methods used in diagnosis, type of definitive management (surgical or non-surgical), and medical procedures are also considered.

The Body mass index (BMI), Waist circumference (WC), blood pressure (BP), and laboratory data related to some of the specific biochemical parameters for the evaluation of goiter function were also obtained for consideration. BMI was calculated as weight (kg) divided by squared height (m²), and obesity was defined as a BMI of 30 kg/m² or higher. Additionally, to measure the BP of the patient standard mercury was used sphygmomanometer. The BP was evaluated in the sitting position after 5 minutes of rest exactly to the right brachial artery. An average of three measurements were taken for each patient and used during the data analysis. A venous blood sample was obtained from each patient to evaluate different biochemical laboratory analysis tests. Hormone levels were analyzed by immune-radiometric assay for TSH and radioimmunoassay for FT4 and ATPO. Insulin and leptin were investigated by an immune-radiometric assay. The laboratory reference values were 10.1-22.0 pmol/L for FT4, 0.27-3.75 mIU/L for TSH, and 4-16 mIU/L for insulin, while the reference value for ATPO was 2.5.

IBM SPSS version 20.0 was used for statistical analysis. We measured the prevalence of goiter based on the relative frequencies and ratios for all patients with goiter. The logistic regression analysis was applied to assess the risk factors and the relationship between variables. P-values less than 0.05 were considered statistically significant.

Results

The prevalence of goiter was 35.7% (116/325) (95% CI, 31.01 to 39.4%). Moreover, the prevalence of goiter in females resulted in 61.2% (71/116) while in males 38.8% (45/116). The mean age was 41.32±10.05 with a minimum and maximum age of 20 to 71. The most affected age resulted in 41-50 years old with 41% (95% CI, 37.4 to 45.8%). Most of the patients presented for medical care lived in the urban areas 60.6% and only

39.4% in the rural areas. Single referred 11.4% of patients, married 69.5% and divorced or widow was 13.2% and 5.8% respectively. Related to the education level, 21.8% referred that have a primary level of education, 56.9% have high school and 21.2% have finished the university. About 52.3% of patients were employed and 47.7% were not employed. Additionally, 23.1% referred to a low monthly income, 48.3% moderate income, and 28.6% high monthly income. Goiter is a disease with a previous family history. All the patients are asked related to the heredity of goiter in their family, but most of them 75.7% referred that not have a family member with goiter, and only 24.3% referred a previous history in their family.

Below we have analyzed some of the most important risk factors for goiter. One of the predictor risks is the female menstrual status. Out of 241 female patients, only 31.2% referred that have a regular menstrual cycle and 61.8%

referred no. According to the daily salt consumption, 17.5% referred that consuming it at a low level, 62.5% at a moderate, and 20% at a high level. BMI in this study is divided into 5 categories from underweight to obese class II and III. Patients in the underweight category resulted at 4.6%, in the normal weight category at 40%, the overweight category at 25.5%, obese class I at 20.6%, and obese class II and III at 9.2%. Related to the habits of our patients, 73.2% referred that have a sedentary daily life, 27.4% were regularly alcohol users, and 35.1% regularly smoking users. Metabolic syndrome appeared in 84.3% of patients. Hypertension was referred from 44% of patients, Diabetes Mellitus from 22.1%, and cardiovascular diseases from 18.1% of patients. The finding showed that age, family history, BMI, and menstrual status had a significant relationship with goiter with a p-value <0.05. Likewise, our study demonstrated metabolic syndrome to be a strong predictor of goiter.

Table 1: Baseline socio-demographic characteristics of patients.

Variables		Frequency	Percentage	p-value
Gender	Female	241	74.15%	0.0001
	Male	84	25.85%	
Age	< 35 years old	31	9.5%	0.0008
	>35-55 years old	209	64.3%	
	>55 years old	85	26.2%	
Residence	Rural	197	60.6%	0.1
	Urban	128	39.4%	
Marital status	Singe	37	11.4%	0.4
	Married	226	69.5%	
	Divorced	43	13.2%	
	Widow	19	5.8%	
Education	Primary level	71	21.8%	0.08
	High school	185	56.9%	
	University	69	21.2%	
Occupation	No	155	47.7%	0.9
	Yes	170	52.3%	
Economic status	Low Income	75	23.1%	0.06
	Moderate	157	48.3%	
	High Income	93	28.6%	
History family	No	79	24.3%	0.002
	Yes	246	75.7%	
Female menstrual status (No=241)	No	149	61.8%	<0.0001
	Yes	92	31.2%	
Salt consumption	Low	57	17.5%	0.007
	Moderate	203	62.5%	
	High	65	20%	
BMI	underweight (BMI: $\leq 18.4\text{kg/m}^2$)	15	4.6%	0.03
	normal weight (BMI: $18.5\text{--}24.9\text{kg/m}^2$)	130	40%	
	overweight (BMI: $25.0\text{--}29.9\text{kg/m}^2$)	83	25.5%	
	obese class I (BMI: $30.0\text{--}34.9\text{kg/m}^2$)	67	20.6%	
	obese class II-III (BMI: $\geq 35.0\text{kg/m}^2$)	30	9.2%	
Physical activities	No	238	73.2%	0.04
	Yes	87	26.8%	
Alcohol use	No	236	72.6%	0.041
	Yes	89	27.4%	
Smoking use	No	211	64.9%	0.03
	Yes	114	35.1%	
Metabolic syndrome	Hypertension	143	44%	0.005
	Diabetes	72	22.1%	
	Cardiovascular diseases	59	18.1%	

Table II shows the diagnostic methods used for the diagnosis of goiter in suspected patients and also the biochemical analysis for evaluation of some of the parameter's predictors for goiter. Sonography is used in 76.3% of females and 51.2% of males. Scintigraphy in 13.3% of females and 28.6% of males. Ct scan in 7% of females and 14.3% of males while MR imaging in 3.3% of females and 5.9% of males. There was found a significant association between the two imagery methods sonographic and scintigraphy and divided by gender (females versus males). Related to the thyroid volume, males appeared a higher volume versus females, on average 15.8 ± 4.9 and 13.0 ± 4.2 respectively. There is found a significant association with p-value <0.0001 . The values of total T3, T4, and anti-TPO were notably higher for females than males, with a significant association between them, p-value <0.05 . Whereas, other parameters such as Tg-antibodies, Insulin, HDL, and LDL were higher in males than females. A significant association was found only for Tg-antibodies, with a p-value of 0.008.

Table III shows the diagnostics findings and clinical presentation of 116 patients diagnosed with goiter. The pain was referred in only 7% of patients, the solitary nodule was only in 15.5% of patients, multiple nodules in 11.2%, thyroid cyst in 4.3% of patients, hypothyroidism in 9.5% of patients, and thyrotoxicosis in 2.6% of patients. About 7% resulted in a goiter 0 grade, 28.4% in goiter grade 1, and 65.6% in goiter grade 2.

Table II: Diagnostic methods and Biochemical Analysis.

Diagnostic methods	Males	Females	P value
Imagery methods	(84)	(241)	
Sonographic	43	184	0.0001
Scintigraphy	24	32	0.02
CT scan	12	17	0.3
MR imaging	5	8	0.7
Biochemical Analysis			
Thyroid volume (mL)	15.8 ± 4.9	13.0 ± 4.2	<0.0001
TSH (μ IU/ml)	61.4 ± 15.70	103.5 ± 48.32	0.002
Total T3 (ng/dL)	3.24 ± 0.72	3.58 ± 1.67	0.02
Total T4 (μ g/dL)	12.6 ± 11	14.21 ± 9.4	0.04
TPO antibodies (kU/L)	0.045 ± 1.2	0.28 ± 1.7	0.008
Tg-antibodies (mmol/L)	1.5 ± 0.9	1.2 ± 0.3	0.01
Insulin (mU/L)	9.6 ± 6.1	8.0 ± 4.2	0.7
HDL (mmol/L)	1.8 ± 0.71	1.7 ± 0.9	0.05
LDL (mmol/L)	3.9 ± 1.2	3.4 ± 1.9	0.9

Approximately 24.1% of patients' definitive management was done with total thyroidectomy, while 75.9% were non-operative.

Table IV shows the logistic regression for some of the risk factors divided by the gender of patients. We found a significant association between more of the analysis factors.

Discussion

Goiter is seen as a frequent screening finding wherein patients may or may not present with clinical symptoms and abnormal laboratory tests⁶. Moreover, it is a common endocrine problem that affects around 300 million people globally, with more than half of those affected being unaware of their condition. Hyperthyroidism and hypothyroidism are the most common thyroid disorders, which affect 1.6 billion people in more than 100 countries around the world¹⁷. In this study, we conducted an observational study in the adult population, aimed to identify the prevalence and risk factors of goiter. The prevalence of goiter resulted in 35.7%, for 95% CI [31.01 to 39.4%]. This prevalence is lower than in another study conducted by Zekarias et al in 2020, which revealed the prevalence of total goiter was 43.3% for 95% CI [39.2-46.9]. Many studies have highlighted some of the risk factors such as gender, BMI, menopause, metabolic syndrome, hypertension, dyslipidemia, and hyperglycemia that may contribute to goiter¹⁹⁻²².

Table III: Distribution by clinical presentation and diagnostic finding.

Distribution by clinical findings (116 goiter cases)	Frequency	Percentage
Clinical findings		
Pain	8	7%
Solitary nodule	18	15.5%
Multiple nodules	13	11.2%
Thyroid cyst	5	4.3%
Hypothyroidism	11	9.5%
Thyrotoxicosis	3	2.6%
Goiter grades		
Goiter 0	8	7%
Goiter 1	33	28.4%
Goiter 2	75	65.6%
Definitive management		
Total thyroidectomy	28	24.1%
Non-operative	88	75.9%

Table IV: Logistic regression for some of the risk factors divided by the gender of patients.

Variables	Males		Females	
	odds ratio	p-value	odds ratio	p-value
Age	2.1 [0.92-3.7]	0.003	3.3 [1.2-5.7]	0.0001
BMI (kg/m ²)	1.5 [0.75-2.9]	0.04	1.8 [0.84-3.0]	0.02
Smoking	2.7 [0.84-6.8]	0.008	0.9 [0.02-2.07]	0.08
Alcohol	1.4 [0.35-3.09]	0.04	0.5 [0.04-1.2]	0.7
Salt consumption	2.2 [0.98-4.5]	0.02	1.7 [0.82-3.81]	0.03
Metabolic syndrome	1.3 [1.2-5.7]	0.01	2.5 [0.97-4.01]	0.02
History family	1.3 [0.62-2.4]	0.04	1.4 [0.77-2.13]	0.03
Thyroid volume (mL)	2.0 [0.75-4.21]	0.02	1.9 [0.61-3.24]	0.008
TSH (μ IU/ml)	1.3 [0.74-2.6]	0.04	1.8 [0.23-3.75]	0.01
Total T3 (ng/dL)	0.98 [0.22-1.54]	0.047	1.2 [0.34-2.46]	0.04
Total T4 (μ g/dL)	1.1 [0.34-1.73]	0.04	1.4 [0.27-2.48]	0.04
TPO antibodies (kU/L)	0.8 [0.12-1.50]	0.3	0.94 [0.34-2.07]	0.05
Tg-antibodies (mmol/L)	0.56 [0.01-1.13]	0.7	1.1 [0.31-2.41]	0.04

A systematic review conducted by Malboosbaf et al, 2012 reported that the subgroup analyses appeared an increasing trend in gender differences around the age of 15 years, and goiter was more frequent in females. This gender difference in the prevalence of goiter is more prominent in iodine-deficient areas, and with grade 2 of goiter, notably after puberty²³. Rapoport et al, show in their study that shown that sex hormones may play a role in thyroid volume only after puberty, suggesting that changes in thyroid volume are influenced by gender differences²⁴. Moreover, women are more likely than men to develop thyroid problems during their lifetime, and this risk is more evident in older women than younger women^{25,26}. Further, in areas with severe or moderate to mild iodine deficiency was observed a higher prevalence of goiter with age, while in areas with severe or moderate iodine deficiency was observed an enlargement of the thyroid gland with age²⁷. In this study, we found a higher significant association between the prevalence of goiter in females compared to males. Females were 2.7 times at risk to develop goiter compared to males for 95% CI [1.66 to 4.59] p-value =0.0001. While patients with age over 41 years old were more likely to develop goiter compared to younger. There was found a significant association between the prevalence of goiter and the age of patients p-value =0.0008

Additionally, metabolic syndrome appeared in 84.3% of patients. Hypertension was referred from 44% of patients, Diabetes Mellitus from 22.1%, and cardiovascular diseases from 18.1% of patients. Whereas the prevalence of BMI among our patients resulted in 55.3%, wherein 25.5% were overweight, 20.6% were obese class I, and 9.2% were obese class II and III. The findings were similar to some other studies²⁸⁻³³. The analysis data showed that age, family history, BMI, and menstrual status had a significant relationship with goiter with a p-value <0.05. Likewise, our study demonstrated metabolic syndrome to be a strong predictor of goiter. Nonetheless, there are many other factors such as habits that are worth further investigation for enough documentation of their implications in the rise of goiter prevalence. Smoking and alcohol habits were known to precipitate metabolic syndrome and some thyroid pathological conditions. Further, physical daily activity is a known etiologic factor of metabolic syndrome^{34,35}. Our female study group was less engaged with habits such as smoking, alcohol, and physical daily activity compared to the males of the same demographic area. Even though females consumed less alcohol or tobacco or performed less daily physical activity than males, besides that we found a strong association between the prevalence of goiter and habits among our patients involved in this study.

Several studies have shown that rates of goiter, nodular goiter, and papillary thyroid cancer are higher in iodine-insufficient areas than in those that have sufficient iodine^{36,37}. Iodine deficiency has been shown to lead to these conditions by increasing TSH levels. TSH is a predominantly proliferative molecule for the thyroid. Elevation of serum levels of TSH causes significant increases in thyroid volume. Elevations, even minimal elevations, in TSH over an adequate amount of time are sufficient for goiter formation³⁸. We have evaluated some of the risk factors and the biochemical parameters of patients diagnosed with goiter. For a more in-depth analysis, we used logistic regression and saw the differences in these parameters between male and female participants in this study. In this study, we found a significant association between gender and some of the risk factors that contribute to the goiter developer.

Conclusions

The prevalence of goiter was relatively high among women. Having a family history and being 41-50 years old increased the risk of goiter. The findings data suggest the need for special attention for females of advanced age, on menopause, obesity, and metabolic syndrome. Patients with confirmed goiter should be screened for age and obesity-related disorders such as metabolic syndrome. They should be examined by physicians and screened with imaging tests and laboratories test for goiter. Moreover, future work is needed to determine whether the characteristics of this study population were involved in generating this observational disagreement.

Ethics approval and consent to participate: Approval for this study was provided by the Director of the Hospital of Gjirokatsra, and all study procedures were approved by the Human Investigation Committees at the Hospital. All methods were applied in accordance with relevant guidelines and regulations. In this survey, no personal data were recorded, and all information was completed anonymously. Additionally, they were informed that participation in the study was voluntary and participants could withdraw at any moment.

Data availability

According to the Statute of the Hospital, the authors cannot share the data underlying this study.

Disclosure Statement

The authors declare no potential conflicts of interest.

Consent for publication

All authors have given their consent for the publication of this paper.

Competing interests

Not applicable.

Funding Source

This research did not receive any specific grant from funding agencies in the public, commercial, or not-for-profit sectors. No financial or any other reward was offered to students who completed the survey.

Acknowledgments

We express our special thanks to all medical staff and study participants who took part in the study, and had marvelous contributions to the success of the study.

References

1. Bruce M. Carlson. The Endocrine System. The Human Body. Book. Chapter 9. 2019, Pages 241-269. <https://doi.org/10.1016/B978-0-12-804254-0.00009-0>
2. World Health Organization. Assessment of iodine deficiency disorders and monitoring their elimination: a guide for programme managers; 2007 [cited 2017 Dec 11]. Available from: http://apps.who.int/iris/bitstream/10665/43781/1/9789241595827_eng.pdf.
3. Andersson M, Takkouche B, Egli I, Allen HE, de Benoist B: Iodine Status Worldwide, WHO Global Database on Iodine Deficiency; Department of Nutrition for Health and Development. Geneva: World Health Organization. 2004.
4. Carlé A, Krejbjerg A, Laurberg P. Epidemiology of nodular goiter. Influence of iodine intake. *Best Practice & Research Clinical Endocrinology & Metabolism*. 2014; 28(4): 465-479. <https://doi.org/10.1016/j.beem.2014.01.001>
5. Bruce M. Carlson. The Endocrine System. The Human Body. Book. Chapter 9. 2019, Pages 241-269. <https://doi.org/10.1016/B978-0-12-804254-0.00009-0>
6. Zheng L, Yan W, Kong Y, Liang P, Mu Y. (2015) An epidemiological study of risk factors of thyroid nodule and goiter in Chinese women. *International journal of environmental research and public health* 12(9): 11608-20.
7. Laurberg P, Knudsen N, Andersen S, Carlé A, Pedersen I B, et al. (2012) Thyroid function and obesity. *European thyroid journal* 1(3): 159-67.
8. Ullah I, Alam N, Ali S, Ul Haq I, Khan I, Asif M. Study on the Prevalence of Goiter and Associated Factors Among Hospitalized Patients of District Timergara, Dir Lower Pakistan. *Biomed J Sci & Tech Res* 41(2)-2022. BJSTR. MS.ID.006563. DOI: 10.26717/BJSTR.2022.41.006563.
9. World Health Organization United Nations Children's Fund, International Council for Control of Iodine Deficiency Disorders. Assessment of iodine deficiency disorders and monitoring their elimination. A guide for programme managers. 2020.
10. Dauksiene D, Petkeviciene J, Klumbiene J, Verkauskiene R, et al. Factors Associated with the Prevalence of Thyroid Nodules and Goiter in Middle-Aged Euthyroid Subjects. *International Journal of Endocrinology* Volume 2017; 8401518: 8. <http://dx.doi.org/10.1155/2017/8401518>.
11. Blanc E, Ponce C, Brodschi D, Nepote A, Barreto A, Schritman M, et al. Association between worse metabolic control and increased thyroid volume and nodular disease in elderly adults with metabolic syndrome. *Metab Syndr Relat Disord*. 2015 Jun;13(5):221-6. doi: 10.1089/met.2014.0158.
12. Knudsen N, Laurberg P, Perrild H, Bülow I, Ovesen L, Jørgensen T. "Risk factors for goiter and thyroid nodules," *Thyroid*. 2002; 12(10): 879-88.
13. Ayturk S, Gursoy A, Kut A, Anil C, Nar A, Tutuncu NB. "Metabolic syndrome and its components are associated with increased thyroid volume and nodule prevalence in a mild-to-moderate iodine-deficient area," *European Journal of Endocrinology*. 2009; 161(4):599-605.
14. Anil C, Akkurt A, Ayturk S, Kut A, Gursoy A. "Impaired glucose metabolism is a risk factor for increased thyroid volume and nodule prevalence in a mild-to-moderate iodine-deficient area," *Metabolism*. 2013;62(7):970-5.
15. Yasar HY, Ertugrul O, Ertugrul B, Ertugrul D, Sahin M. "Insulin resistance in nodular thyroid disease," *Endocrine Research*. 2011;36(4):167-74.
16. Wiersinga WM. "Smoking and thyroid," *Clinical Endocrinology*. 2013;79(2):145-51.
17. Abdullaeva M, Kasimova G, Yaxudayev E, Sakhibova M, Bakhavadinova Z, et al. The Influence of Dysfunction of the Autonomic System and the Thyroid Gland on the Course of Bronchial Asthma (BA) in Children. *Int J Cur Res Rev*. 2020; 12(14): 36
18. Zekarias B, Mesfin F, Mengiste B, Tesfaye A, Getacher L. Prevalence of Goiter and Associated Factors among Women of Reproductive Age Group in Demba Gofa Woreda, Gamo Gofa Zone, Southwest Ethiopia: A Community-Based Cross-Sectional Study. *Journal of Nutrition and Metabolism* Volume 2020, Article ID 5102329, 9 pages. 2020. <https://doi.org/10.1155/2020/5102329>.
19. Amihaesei IC, Chelaru L. Metabolic syndrome a widespread threatening condition; risk factors, diagnostic criteria, therapeutic options, prevention and controversies: an overview. *Rev Med Chir Soc Med Nat Iasi* 2014; 118: 896-900.
20. Arduc A, Dogan BA, Tuna MM, Tutuncu Y, Isik S, Berker D et al. Higher body mass index and larger waist circumference may be predictors of thyroid carcinoma in patients with Hurthle-cell lesion/

- neoplasm fine-needle aspiration diagnosis. *Clin Endocrinol (Oxf)* 2014; [Epub ahead of print].
21. Guo H, Sun M, He W, Chen H, Li W, Tang J, et al. The prevalence of thyroid nodules and its relationship with metabolic parameters in a Chinese community-based population aged over 40 years. *Endocrine* 2014; 45: 230-5.
22. Cappelli C, Castellano M, Pirola I, De Martino E, Gandossi E, Delbarba A, et al. Reduced thyroid volume and nodularity in dyslipidaemic patients on statin treatment. *Clin Endocrinol (Oxf)* 2008; 68: 16-21.
23. Malboosbaf R, Hosseinpanah F, Mojarrad M, Jambarsang S, Azizi F. Relationship between goiter and gender: a systematic review and meta-analysis. *Endocrine* 43, 539-47 (2013). <https://doi.org/10.1007/s12020-012-9831-8>.
24. Rapoport B, Chazenbalk G D, Jaume J C, McLachlan S M (1998) The thyrotropin (TSH)-releasing hormone receptor: interaction with TSH and autoantibodies. *Endocrine reviews* 19(6): 673-716.
25. Wiersinga W M (2013) Smoking and thyroid. *Clinical endocrinology* 79(2): 145-151. 32. Bukhari U, Sadiq S (2008) Histopathological audit of goiter: A study of 998 thyroid lesions. *Pakistan Journal of Medical Sciences* 24(3): 442.
26. Derumeaux H, Valeix P, Castetbon K, Bensimon M, Boutron-Ruault MC, et al. (2003) Association of selenium with thyroid volume and echostructure in 35-to 60-year-old French adults. *European Journal of Endocrinology* 148(3): 309-15
27. Adesunkanmi A R K, Makinde O N (2003) Goitre prevalence in pregnant women attending antenatal clinic in a teaching hospital. *Journal of Obstetrics and Gynaecology* 23(2): 156-9.
28. Kir S, Aydin Y, Coskun H. Relationship between metabolic syndrome and nodular thyroid diseases. *Scand J Clin Lab Invest.* 2018 Feb - Apr;78(1-2):6-10.
29. Tsatsoulis A. The role of insulin resistance/ hyperinsulinism on the rising trend of thyroid and adrenal nodular disease in the current environment. *J Clin Med.* 2018 Feb;7(3):E37.
30. Buscemi S, Massenti FM, Vasto S, Galvano F, Buscemi C, Corleo D, et al. Association of obesity and diabetes with thyroid nodules. *Endocrine.* 2018 May;60(2):339-47.
31. Răcățăianu N, Leach N, Bondor CI, Mârza S, Moga D, Valea A, et al. Thyroid disorders in obese patients. Does insulin resistance make a difference? *Arch Endocrinol Metab.* 2017 Dec;61(6):575-83.
32. Feng S, Zhang Z, Xu S, Mao X, Feng Y, Zhu Y, et al. The Prevalence of Thyroid Nodules and Their Association with Metabolic Syndrome Risk Factors in a Moderate Iodine Intake Area. *Metab Syndr Relat Disord.* 2017 Mar; 15(2):93-7
33. Tang Y, Yan T, Wang G, Chen Y, Zhu Y, Jiang Z, et al. Correlation between Insulin Resistance and Thyroid Nodule in Type 2 Diabetes Mellitus. *Int J Endocrinol.* 2017;2017: 1617458.
34. Damasceno DC, Sinzato YK, Bueno A, Dallaqua B, Lima PH, Calderon IM, et al. Metabolic profile and genotoxicity in obese rats exposed to cigarette smoke. *Obesity (Silver Spring)* 2013; 21: 1596-601.
35. Rendina D, De Palma D, De Filippo G, De Pascale F, Muscariello R, Ippolito R, et al. Prevalence of Simple Nodular Goiter and Hashimoto's Thyroiditis in Current, Previous, and Never Smokers in a Geographical Area with Mild Iodine Deficiency. *Horm Metab Res* 2015; 47: 214-219.
36. Cao LZ, Peng XD, Xie JP, Yang FH, Wen HL, Li S. The relationship between iodine intake and the risk of thyroid cancer: a meta-analysis. *Medicine (Baltimore).* 2017 May; 96(20):e6734.
37. Zimmermann MB, Galetti V. Iodine intake as a risk factor for thyroid cancer: a comprehensive review of animal and human studies. *Thyroid Res.* 2015 Jun;8:8
38. Simsir IY, Cetinkalp S, Kabalak T. Review of Factors Contributing to Nodular Goiter and Thyroid Carcinoma. *Medical Principles and practical.* 2020; 29:1-5. DOI: 10.1159/000503575.

The role of nurses in violence against healthcare professionals: a population-based study

El papel de las enfermeras en la violencia contra los profesionales sanitarios: un estudio de base poblacional

Selman Kizilkaya¹ , Altuğ Çağatay² 

1. Dicle University, Faculty of Economics and Administrative Sciences, Health Management Department, Diyarbakır, Turkey
2. Gaziosmanpaşa University, Vocational School of Health Care, Department of Office Management and Executive Assistance, Tokat, Turkey

Corresponding author

Selman Kizilkaya
E-mail: Selman.kizilkaya@dicle.edu.tr

Received: 16 - I - 2023

Accepted: 17 - II - 2023

doi: 10.3306/AJHS.2023.38.03.122

Abstract

Objective: This study aimed to evaluate the impact of nurses' counseling abilities on the desire to use violence toward medical workers.

Materials and methods: The population of the research consists of individuals over the age of 18 who received health services from any hospital in the last 1 year in Turkey. The sample was randomly selected. The survey method was preferred at the point of data collection. The questionnaires were delivered to the participants face-to-face.

Results: A total of 1042 individuals were included in the present study. 63% were female and 37% were male. The average age was recorded as 26.9 years. Of them, 32% were married and 28% had low income. A negative correlation was found between the intention to use violence against healthcare professionals and the counseling skills of nurses ($r=-0.118$, $p<0.01$). Counseling skills of the nurses have a negative effect on the intention to inflict violence on healthcare workers ($t=-3.832$, $p<0.01$) and a positive effect on the attitude towards the behavior ($t=4.228$, $p<0.01$).

Conclusions: Social initiatives should be used to reduce violence. There should be the development of intervention strategies for public hospitals and emergency services. Employees should be instructed to let the public know that there might be a wait while the examination is taking place. Violence should be addressed legally, and risk groups exposed to violence should be given priority in intervention strategies.

Key words: Attitude towards behavior, counseling skill, intention, violence.

Resumen

Objetivo: Este estudio tuvo como objetivo evaluar el impacto de las habilidades de asesoramiento de las enfermeras en el deseo de usar la violencia hacia los trabajadores médicos.

Material y métodos: La población de la investigación está formada por individuos mayores de 18 años que recibieron servicios sanitarios de cualquier hospital en el último año en Turquía. La muestra fue seleccionada al azar. Se prefirió el método de la encuesta en el momento de la recogida de datos. Los cuestionarios se entregaron a los participantes cara a cara.

Resultados: En el presente estudio se incluyó a un total de 1042 individuos. El 63% eran mujeres y el 37% hombres. La edad media se registró como 26,9 años. De ellos, el 32% estaban casados y el 28% tenían bajos ingresos. Se encontró una correlación negativa entre la intención de usar la violencia contra los profesionales de la salud y las habilidades de asesoramiento de las enfermeras ($r=-0,118$, $p<0,01$). Las habilidades de asesoramiento de las enfermeras tienen un efecto negativo sobre la intención de ejercer violencia sobre los profesionales sanitarios ($t=-3,832$, $p<0,01$) y un efecto positivo sobre la actitud hacia el comportamiento ($t=4,228$, $p<0,01$).

Conclusiones: Las iniciativas sociales deberían utilizarse para reducir la violencia. Se deberían desarrollar estrategias de intervención para los hospitales públicos y los servicios de emergencia. Se debe instruir a los empleados para que informen al público de que puede haber una espera mientras se realiza el examen. La violencia debe ser abordada legalmente, y los grupos de riesgo expuestos a la violencia deben tener prioridad en las estrategias de intervención.

Palabras clave: Actitud hacia el comportamiento, habilidad de asesoramiento, intención, violencia.

Introduction

Violence, which has emerged in different forms since the existence of humanity; can be defined as physical, psychological, and economic harm resulting from the use of power and authority against oneself, another person, and any community, resulting in any injury or death. Many studies have been conducted on violence until today and there have been different definitions in the literature¹⁻³. According to the type of violence; physical, psychological, verbal, sexual, economic, and cyber violence. Although violence is mostly defined as physical, it can be said that other types of violence are also common and violent behaviors are increasing even more today. Violence can occur against people, regardless of race, language, ethnicity, sexual orientation, or gender, in society, at home, and work, and studies have shown that the news of violence in health has become widespread recently and violence has increased in this sense⁴.

Violence in health institutions "comes from the patient, patient relatives or any other individual, poses a risk to the health worker; threatening behavior, verbal threat, physical assault, and sexual assault"⁵. With the increase in violence in the health sector, health workers have also become the most important target and victim of these violent events. According to the report "Occupational Violence in the Health Sector", 25% of all violence takes place in the health sector. Studies show that healthcare personnel, especially nurses, frequently encounter violence in their work environment^{5,6}.

Studies have shown that counseling skills are an important factor in nurses against violence⁷. This study aimed to evaluate the impact of nurses' counseling abilities on the desire to use violence toward medical workers.

Materials and methods

The population of the research consists of individuals over the age of 18 who received health services from any hospital in the last 1 year in Turkey. The sample was randomly selected.

In this study, the survey method was preferred at the point of data collection. The questionnaires were delivered to the participants face-to-face. In addition to the descriptive personal characteristics of the participants, the questionnaire includes statements that reveal the intention to use violence against health workers and their views on the counseling skills of nurses. "Intention to Violence against Healthcare Professionals Scale" is about violence against healthcare professionals. The scale was developed by Şanlıtürk and Boy⁸. On the scale, individuals' intention to use violence 1 item (1); past experiences 1 item (2); and attitude towards behavior, which is the three components of intention,

6 items (3,4,5,6,7,8); subjective norm (SN) 5 items (9,10,11,12,13) and perceived behavioral control 2 items (14, 15) are included. These statements were structured with a 5-point evaluation between 1: I strongly disagree, 5: I strongly agree. In calculating the scale scores, the scores of the subgroups of each scale are calculated separately. A high score on the scale indicates a high willingness to exhibit violent behavior. In addition, a high score on attitude towards the behavior, which is the sub-dimension of the scale, indicates that the person perceives that behavior as positive; If the subjective norm score is high, there is environmental pressure for the individual to perform the target behavior; A high score in the perceived behavior control sub-dimension indicates that the person has a strong control towards performing the behavior. There is no negative item on the scale. As a result of the reliability analysis made in the research, Cronbach's Alpha coefficient was determined as 0.71.

"Nurses Counseling Skills Scale" was developed by Avci and Kumcagiz⁹, and there are 10 statements in total on the scale. For these statements, the participants were allowed to answer between Never (1) and Always (5). In the validity and reliability study of the scale, Cronbach's Alpha coefficient was found to be 0.88. In this study, this value was determined as 0.96.

Results

A total of 1042 individuals were included in the present study. 63% were female and 37% were male. The average age was recorded as 26.9 years. Of them, 32% were married. Only 44% of them actively work in a job and 28% have low income, 60% are middle-income, and 11% have a high income. Other relevant demographic data are summarized in **table I**.

Table II shows the results of the correlation analysis of the relationship between the counseling skills of nurses and their intention to use violence against healthcare professionals. Accordingly, it is seen that there is a negative and significant relationship between the intention to use violence against healthcare professionals and the counseling skills of nurses ($r=-0.118$, $p<0.01$). It is seen that there is a positive and significant relationship between the attitude towards the behavior and the counseling skills of the nurses. In this part, it is seen that there is no significant relationship between past experience, subjective norms and perceived behavioral control, and the counseling skills of nurses. When we look at the results of the correlation analysis according to age, it is seen that there is no significant relationship between age and intention, past experience, attitude towards behavior, and the counseling skills of nurses. A positive and significant relationship was found between age and subjective norm ($r=0.112$, $p<0.01$) and perceived behavioral control ($r=0.113$, $p<0.01$).

Table III list the regression results for the effect of nurses' counseling skills on their intention to commit violence against healthcare professionals. Accordingly, it is seen that the counseling skills of the nurses have a significant and negative effect on the intention to inflict violence on healthcare workers ($t=-3.832$, $p<0.01$).

It is seen that the effect of the counseling skills of the nurses on the attitude towards the behavior is at a positive and significant level ($t=4.228$, $p<0.01$). It is seen that the counseling skills of nurses do not have a significant effect on past experience, subjective norms and perceived behavioral control.

Table I: Demographic data.

		Mean	SD
Age		26,96	8,497
Gender	Women	n 657	% 63,1
	Men	385	36.9
	Total	1042	100.0
Marital Status	Married	n 342	% 32.8
	Single	700	67.2
	Total	1042	100.0
Child Ownership	I have children	n 305	% 29.3
	I have no children	737	70.7
	Total	1042	100.0
Working Status	I am not working	n 578	% 55.5
	I am working	464	44.5
	Total	1042	100.0
Perceived income level	Low	n 298	% 28.6
	Middle	626	60.1
	High	118	11.3
	Total	1042	100.0
Do you have any chronic disease?	Yes	n 127	% 12.2
	No	915	87.8
	Total	1042	100.0
How many times do you go to the hospital a year?	1-3 times	n 596	% 57.2
	4-7 times	297	28.5
	8-11 times	81	7.8
	12 times or more	68	6.5
	Total	1042	100.0
Considering the hospital where the last service was received, the approximate time spent in the hospital	Under 2 hours	n 599	% 57.5
	2-5 hours	329	31.6
	Over 5 hours	114	10,9
	Total	1042	100,0

Table II: Correlations between items.

	Mean	SD	1	2	3	4	5	6	7
Intention (1)	1.17	.665	-						
Past Behavior (2)	1.14	.624	.598**	-					
Attitude Toward Behavior (3)	17.13	3.801	.211**	.181**	-				
Subjective Norm (4)	9.60	4,321	.267**	.253**	.383**	-			
Perceived Behavioral Control (5)	3.61	2.080	.231**	.228**	.224**	.322**	-		
The Counseling Skills of Nurses (6)	40.65	10.602	-.118**	-.040	.130**	.042	-.003	-	
Age (7)	26.96	8.497	.052	.055	-.032	.112**	.113**	-.007	-

** Correlation is significant at the 0.01 level (2-tailed).

Table III: Regression results for the effect of nurses' counseling skills.

Variables	β	t	R	R Square	F	p
Intention	-.118	-3.832	.118	.014	14.683	.00
Past Behavior	-.040	-1.301	.040	.002	1.693	.19
Attitude Toward Behavior	.130	4.228	.130	.017	17.876	.00
Subjective Norm	.042	1.352	.042	.002	1.828	.18
Perceived Behavioral Control	-.003	-.087	.003	.000	.008	.93

Discussion

Violence is a phenomenon that has existed for as long as there has been humankind, and it has both individual and social components. The World Health Organization defines violence as the threat or intentional use of physical or psychological harm, maltreatment, or neglect against oneself, another person, or a group that results in (or is likely to result in) harm, injury, or death¹⁰. "Incidents in which an employee is abused or attacked by a person or persons during work-related situations" are what is meant by the term "workplace violence." "The patient, the patient's relatives or any other individual that poses a risk to the health worker; threatening behavior, verbal threat, economic abuse, physical assault and sexual assault" are the definitions of violence in medical institutions¹¹.

In a study by Winstanley et al. in state hospitals in England, 68.0% of the participants had exposed to verbal abuse¹²; in a study in the USA, the frequency of verbal abuse among emergency physicians was 74.9%¹³; and in Turkey, the frequency ranged between 53.7% and 60.0%¹⁴. The fact that verbal violence occurs frequently across all studies may be related to the fact that physical violence carries tougher punishments. As a result, people may express their emotions more freely and feel more at ease, believing that their actions were justified given the tense situation and that they would not have done so otherwise. Because one of the factors contributing to the gradual rise in physical violence against healthcare workers is the absence of effective deterrent punishment for those who commit such crimes, particularly in Turkey.

Nurses' interactions with patients heavily rely on their counseling abilities. Despite the fact that there are various health professionals working in specialties like gynecology, neurology, stoma care, cancer and palliative care, counseling skills are frequently used in almost every nurse-patient interaction¹⁵. The nurse's counseling abilities enable her to assist the patient or her family in learning about the disease, the treatment process, encouraging them to use practical resources to deal with their issues, and gaining access to scientific knowledge⁹. This is also a significant contributor to violence against healthcare professionals. In line, we found that there is a negative and significant relationship between the intention to use violence against healthcare professionals and the counseling skills of nurses ($r=-.118$, $p<.01$). Similarly, found that there is a positive and significant

relationship between the attitude towards, the behavior and the counseling skills of the nurses. Therewithal, there is no significant relationship between age and intention, past experience, attitude towards behavior, and the counseling skills of nurses.

In a study, it was shown that working in a health institution is 16 times more risky in terms of being exposed to violence compared to other workplaces¹⁶. Studies show that patients' relatives as well as patients inflict violence on healthcare workers. Verbal violence was reported to be more frequent than physical violence^{14,16}. The main reason for this is that health centers are less secure than other working areas. However, it is reported that the nurse's counseling abilities enable her to assist the patient or her family and the nurse aims to implement practices for reorganizing the physical, emotional and social well-being of the patient/patient relative with the counseling skills he/she has based on his/her education and clinical experience⁹. Accordingly, we found that the counseling skills of the nurses have a significant and negative effect on the intention to inflict violence on healthcare workers ($t=-3.832$, $p<0.01$). It is seen that the effect of the counseling skills of the nurses on the attitude towards the behavior is at a positive and significant level ($t=4.228$, $p<0.01$). It is seen that the counseling skills of nurses do not have a significant effect on past experience, subjective norms and perceived behavioral control.

Conclusions

Social initiatives should be used to reduce violence. There should be the development of intervention strategies for public hospitals and emergency services. Employees should be instructed to let the public know that there might be a wait while the examination is taking place. Violence should be addressed legally, and risk groups exposed to violence should be given priority in intervention strategies.

Funding

No Funding

Conflict of interest

The authors declare that they have no conflict of interest

References

1. Kumari A, Kaur T, Ranjan P, Chopra S, Sarkar S, Baitha U. Workplace violence against doctors: Characteristics, risk factors, and mitigation strategies. *J Postgrad Med.* 2020 Jul-Sep;66(3):149-54. doi: 10.4103/jpgm.JPGM_96_20.
2. Demir Y, Mermutluoğlu Ç. Leptospirosis accompanying COVID-19: A case report. *Journal of Clinical Trials and Experimental Investigations* 22; 1(2). doi: 10.5281/zenodo.6980315.
3. Baber A. The effect of the COVID-19 pandemic on the psychological state of healthcare workers around the world: A review. *The Injector* 2022;1(1). doi: 10.5281/zenodo.6501610.
4. Bambi S, Foà C, De Felippis C, Lucchini A, Guazzini A, Rasero L. Workplace incivility, lateral violence and bullying among nurses. A review about their prevalence and related factors. *Acta Biomed.* 2018 Jul 18;89(6-S):51-79. doi: 10.23750/abm.v89i6-S.7461.
5. Palma A, Ansoleaga E, Ahumada M. Violencia laboral en trabajadores del sector salud: revisión sistemática [Workplace violence among health care workers]. *Rev Med Chil.* 2018 Feb;146(2):213-22. Spanish. doi: 10.4067/s0034-98872018000200213.
6. Viero A, Barbara G, Montisci M, Kustermann K, Cattaneo C. Violence against women in the Covid-19 pandemic: A review of the literature and a call for shared strategies to tackle health and social emergencies. *Forensic Sci Int.* 2021 Feb;319:110650. doi: 10.1016/j.forsciint.2020.110650.
7. Zhang X, Li Y, Yang C, Jiang G. Trends in Workplace Violence Involving Health Care Professionals in China from 2000 to 2020: A Review. *Med Sci Monit.* 2021 Jan 8;27:e928393. doi: 10.12659/MSM.928393.
8. Döndü Ş, Yasemin B. Determination of the Society's Perceptions, Experiences, and Intentions to Use Violence Against Health Professionals. *Saf Health Work.* 2021 Jun;12(2):141-6. doi: 10.1016/j.shaw.2020.12.004.
9. Avcı IA, Kumcağiz H. Hemşirelerde Danışmanlık Becerileri Ölçeği'ni (HDBÖ) Geliştirilmesi: Geçerlik ve Güvenirlik Çalışması. *Eskişehir Osmangazi Üniversitesi Sosyal Bilimler Dergisi* 2019;20:873-84.
10. WHO. World Report on Violence and Health 2002.
11. Warshaw LJ, Messite J. Workplace violence: preventive and interventive strategies. *J Occup Environ Med.* 1996 Oct;38(10):993-1006. doi: 10.1097/00043764-199610000-00009.
12. Winstanley S, Whittington R. Aggression towards health care staff in a UK general hospital: variation among professions and departments. *J Clin Nurs.* 2004 Jan;13(1):3-10. doi: 10.1111/j.1365-2702.2004.00807.x.
13. T Kowalenko T, Walters BL, Khare RK, Compton S, Michigan College of Emergency Physicians Workplace Violence Task Force. Workplace violence: a survey of emergency physicians in the state of Michigan. *Ann Emerg Med.* 2005 Aug;46(2):142-7. doi: 10.1016/j.annemergmed.2004.10.010.
14. Ayrancı U, Yenilmez C, Balci Y, Kaptanoğlu C. Identification of violence in Turkish health care settings. *J Interpers Violence.* 2006 Feb;21(2):276-96. doi: 10.1177/0886260505282565.
15. Freshwater D. Counselling skills for nurses, midwives and health visitors. McGraw-hill education (UK), 2003.
16. Elliott PP. Violence in health care. *Nursing management* 1997;28(12):38.

Epidemiological profile of overload among paramedical staff at the regional hospital in southern Morocco

Perfil epidemiológico de la sobrecarga entre el personal paramédico del hospital regional del sur de Marruecos

Mohamed Boukrim^{1,2} , Majdouline Obtel^{1,3} , Abderrahmane Achbani^{2,4} , Rachid Razine^{1,3} 

1. Laboratoire de Biostatistics, clinical Research and Epidemiology- Faculty of Medicine and Pharmacy. Mohamed V University, RABAT, Morocco 2. Higher Institute of Nursing Professions and Health Techniques, Marrakech
3. Laboratory of Social Medicine (Public Health, Hygiene and Preventive Medicine), Faculty of Medicine and Pharmacy of Rabat, Mohamed V University, 10100 Rabat, Morocco 4. Department of biology. Faculty of Sciences, Ibn Zohr University, Agadir, Morocco

Corresponding author

Mohamed Boukrim

E-mail: boukrim1967@gmail.com

Received: 18 - I - 2023

Accepted: 20 - II - 2023

doi: 10.3306/AJHS.2023.38.03.127

Abstract

Introduction: Overweight is a global public health problem. It is considered a major risk factor for chronic conditions such as hypertension, diabetes, hyperlipidaemia and certain cancers. It affects all categories of the population. To this end, the study aims to investigate the prevalence of obesity and overweight as well as the associated factors among health care personnel in a regional hospital in southern Morocco.

Methods: This was a descriptive cross-sectional study of nurses at the regional hospital. Anthropometric measurements were carried out in accordance with WHO recommendations. Weight was measured using a MEDISANA RETRO PSD scale and height using a wall-mounted scale graduated in cm. The data were processed using IBM SPSS version 20 software.

Results: The mean BMI in women was 26.18 (SD \pm 3.77) compared to 25.76 in men (SD \pm 3.62). Almost two thirds (62.57%) were overweight, of which 16% were obese. The study showed that 65% of the weight load was recorded among nurses (of which 17.20% were obese). In addition, 64.9% (of which 19% were obese) of the overweight was recorded among those who were on call or on-call, followed by those who were on regular duty.

Conclusion: Shift work disrupts regular sleep, eating and exercise patterns, which can make it harder to maintain a healthy weight.

Key words: Weight load, nurse, hospital, risk factors.

Resumen

Introducción: El sobrepeso es un problema de salud pública mundial. Se considera un importante factor de riesgo de enfermedades crónicas como la hipertensión, la diabetes, la hiperlipidemia y ciertos cánceres. Afecta a todas las categorías de la población. Con este fin, el estudio pretende investigar la prevalencia de la obesidad y el sobrepeso, así como los factores asociados, entre el personal sanitario de un hospital regional del sur de Marruecos.

Métodos: Se trata de un estudio descriptivo transversal de las enfermeras del hospital regional. Se realizaron mediciones antropométricas de acuerdo con las recomendaciones de la OMS. El peso se midió con una báscula MEDISANA RETRO PSD y la altura con una báscula de pared graduada en cm. Los datos se procesaron con el programa informático IBM SPSS versión 20.

Resultados: La media del IMC en las mujeres fue de 26,18 (DE \pm 3,77) frente a 25,76 en los hombres (DE \pm 3,62). Casi dos tercios (62,57%) tenían sobrepeso, de los cuales el 16% eran obesos. El estudio mostró que el 65% de la carga de peso se registraba entre las enfermeras (de las cuales el 17,20% eran obesas). Además, el 64,9% (de los cuales el 19% eran obesos) del sobrepeso se registró entre los que estaban de guardia o de guardia, seguidos de los que estaban de servicio regular.

Conclusión: El trabajo por turnos altera los patrones regulares de sueño, alimentación y ejercicio, lo que puede dificultar el mantenimiento de un peso saludable.

Palabras clave: Carga de peso, enfermera, hospital, factores de riesgo.

Introduction

Overweight and obesity are defined by the World Health Organisation (WHO) as an abnormal or excessive accumulation of fat in adipose tissue, which can be harmful to health. The resulting diseases are related to the distribution of fat in obese individuals. Thus, in subjects with android obesity there is a higher risk than in those with gynoid obesity¹.

The causes of excess weight are lack of physical activity, eating behaviour, sedentary lifestyle, socio-cultural level and over-consumption of alcohol, in addition to genetic, environmental and psycho-social factors. To these must be added individual biological predispositions related to age, sex and ethnicity².

Obesity is considered a major risk factor for chronic conditions such as hypertension, diabetes, hyperlipidaemia and certain cancers³. It is also clear that the distribution of body fat can increase the risk of hypertension and other cardiovascular diseases, even in people with an average body mass index (BMI), especially in women^{4,5}.

In addition to the consequences of overweight on the body and the psychology of individuals, it also has costs associated with reduced productivity at work.

For example, obese employees experience work-related difficulties in terms of the time required to complete tasks and the physical demands of the job. They are also more likely to have more medical visits and hospitalizations than their normal weight counterparts⁶⁻⁸.

The prevalence of obesity almost tripled globally between 1975 and 2016. For example, in 2016, 39% (38% of men and 40% of women) of adults over 18 were overweight and 13% were obese (11% of men and 15% of women)⁹.

Morocco is undergoing a food transition that affects both urban and rural areas due to urbanisation, economic development and globalisation. This is leading to changes in eating habits, the tendency to consume ready-made meals and fast food which contain a high level of salt, sugar and fat¹⁰. Moreover, in Morocco, the prevalence of overweight has evolved between 2001 and 2018 by 41% (from 37.7% to 53%) in the general population, while obesity has almost doubled (from 10.7% to 20%)^{11,12}.

Studies of overweight have shown that most sectors are affected. Indeed, in Ghana, about 34% of female teachers were overweight, while 27% were obese¹³. Among workers at the autonomous port of Abidjan, obesity is 38.1%¹⁴.

Studies among health professionals also suffered from overweight. Thus, working in the health and social care

sector is associated with a higher prevalence of obesity¹⁵. In addition, studies in hospitals have shown that workers who exercise for long hours are more likely to be obese due to changes in body regulation, metabolism and stress^{16,17}.

In addition, one study showed that the frequency of obesity and overweight was 14.3% and 28.8% respectively in the study population¹⁸. While those conducted in Tunis and Texas hospitals showed a prevalence of overweight and obesity of 43.3% and 25.1% respectively in Tunis and a weight load of 78.1% for those in Texas^{19,20}.

Moreover, women were the most affected by the phenomenon. Thus, studies carried out in hospitals revealed that obesity was more common among women. Indeed, in the national hospital of Chad 28.2% of women were obese¹⁸. Similarly, in the hospital of Parakou in Benin, the proportion of obese women was 84.3%² and in Nigeria, obesity accounted for 62.6%²¹.

In Morocco, studies on the subject are rare. In this perspective, the study aims to investigate the prevalence of obesity and overweight as well as the associated factors among the nursing staff of a regional hospital in southern Morocco.

Patients and methods

This is a descriptive cross-sectional study conducted between January 2021 and June 2021 among the nursing staff of the regional hospital centre. The study population was represented by paramedical staff working in the hospital's inpatient and medico-technical departments.

Data were collected by questionnaire for socio-demographic information, nature and habits of work, behaviours (sedentary lifestyle, diet) and perception of obesity and overweight.

Anthropometric measurements were carried out in accordance with WHO recommendations. Weight was measured using a MEDISANA RETRO PSD scale and height was measured using a wall-mounted scale graduated in cm.

The data were processed using IBM SPSS version 20 software.

Ethics: The study was conducted with the free and informed consent of the participants. Survey participants were assured that all data would be used for research purposes only. Participants' responses were anonymous and confidential.

Results

171 caregivers participated in the study, 62% of the participants were female. More than 92% of the study

participants had a higher education level and more than 37% were of Arab ethnicity. As for marital status, more than half of the participants were married and about 34% were single. The study reveals the youthful character of the participants (33.96 ±9.12 years) as more than three quarters of the participants were below the age of 40 years.

The mean BMI for women was 26.18 (SD ±3.77) compared to 25.76 for men (SD ±3.62). 37.43% of the population were of normal weight while 62.57% were overweight, 16% of whom were obese. More than half of the population was on home guard duty (55%) and more than 46% performed their activities in a standing position (**Table I**).

By gender, 36.8% of women were of normal weight and 63.2% were overweight, of whom 18.00% were obese. Among men, 38.5% were of normal weight and 61.50% were overweight, including 13.80% who were obese.

The average BMI by age group shows that all age groups were overweight and that this decreases with age. More than three quarters of the overweight were in the²⁰⁻²⁹ and²⁹⁻³⁹ age groups, with 42.50% and 33.8% respectively.

Table I: Distribution of the population by socio-demographic characteristics.

Variables	Average ± SD	n (%)
Weight in Kg	71.85±10.21	
Height in cm	1.66±0.06	
BMI in Kg/m ²	26.02±3.71	
Age		
[20,29]		62 (36.3)
[30,39]		69 (40.4)
[40,49]		28 (6.4)
+50 ans		12 (7)
Gender		
Male		106 (62)
Female		65 (38)
Ethnicity		
Sahrawi		54 (31,6)
Arabic		64 (37,4)
Berber		53 (31,0)
Marital status		
Married		95 (55.6)
Single		58 (33.9)
Divorced		18 (10.5)
Educational level		
Secondary		16 (7.6)
Higher		158 (92.4)
Working hours		
Residential custody		94 (55)
On-call duty		9 (5.3)
Normal working hours		68 (39.8)
Position at work		
Standing		74 (46.3)
Sitting		53 (31)
Walking		42 (24.6)
BMI in Kg/m²		
-24		64 (37.4)
[25,30[80 (46.8)
+30		27 (15.8)

According to ethnicity, the weight load was 69.5% among the Berbers (40.7% were obese), compared to 66% among the Arabs (including 22.22% obese) and 64.5% among the Saharawi's (including 37% obese). Furthermore, there is a high prevalence of overweight among the Arab ethnic group (43.75%) compared to 27.5% among the Saharawi's. On the other hand, the Berbers have the highest prevalence of obesity (40.74%).

According to the level of education, the study reveals that almost all of the overweight was recorded among people with a higher level of education.

According to marital status, overweight affected more than half of married people, whereas it was 36.2% among single people and 8.8% among divorced people (**Table II**).

IMC et environnement du travail:

Quant au travail et à son environnement, le recodage du cadre d'appartenance en cadre infirmiers et autres (vu l'effectif réduit des autres cadres) a montré que 65 % de la charge pondérale est enregistré chez les infirmiers (dont 17.20% d'obèses) et 35% chez les autres cadres. La répartition du surpoids selon la fonction exercée au niveau de l'hôpital a montré que 66.2% représentait le personnel soignant dont 16.90% était obèses. En fonction de la position au travail, le surpoids était présent chez 63.8% chez ceux qui travail en position debout alors qu'elle n'est que de 11.2% chez les autres qui marchaient. En ce qui concerne, les horaires de travail, 64.9% (dont 19% d'obèses) du surpoids a été enregistrée chez ceux qui assuraient la garde ou l'astreinte suivi de ceux qui assuraient l'horaire normal (**Table III**).

Table II: Distribution of weight status by socio-demographic characteristics.

Variables	BMI in Kg/m ²		
	- 25 Kg/m ²	[25,30[Kg/m ²	+30 Kg/m ²
Age			
[20,29]	21 (32.8)	34 (42.5)	7 (25.9)
[30,39]	28 (43.8)	27 (33.8)	14 (51.9)
[40,49]	7 (10.9)	15 (18.8)	6 (22.2)
+50 ans	8 (12.5)	4 (5.0)	0 (0)
Gender			
Male	25 (39.1)	31 (38.8)	9 (33.3)
Female	39 (60.9)	49 (61.2)	18 (66.7)
Ethnicity			
Sahrawi	22 (34.4)	22 (27.5)	10 (37.0)
Arabic	23 (35.9)	35 (43.8)	6 (22.2)
Berber	19 (39.7)	23 (28.8)	11 (40.7)
Marital status			
Married	33 (51.6)	44 (55)	18 (66.7)
Single	24 (37.5)	29 (36.2)	5 (18.5)
Divorced	7 (10.9)	7 (8.8)	4 (14.8)
Educational level			
Secondary	7 (10.9)	6 (7.5)	0 (0)
Higher	57 (89.1)	74 (92.5)	27 (100)

Table III: Distribution of weight status by work environment.

Variables	BMI in Kg/m ²		
	- 24 Kg/m ²	[25,30[Kg/m ²	+30 Kg/m ²
Framework			
nurse	44 (68.8)	52 (65)	20 (74.1)
Other	20 (31.2)	28 (35)	7 (25.9)
Working hours			
Guard	31 (50)	50 (64.9)	19 (73.1)
Normally	31 (50)	27 (35.1)	7 (26.9)
Position at work			
Standing	16 (25.8)	51 (63.8)	7 (25.9)
Sitting	21 (33.9)	20 (25)	12 (44.4)
Walking	25 (40.3)	9 (11.2)	8 (29.6)
Function			
Head of unit	6 (9.4)	3 (3.8)	0 (0)
Nursing	45 (70.3)	53 (66.2)	20 (74.1)
Other	12 (20.3)	24 (30)	7 (25.9)

Perception and Lifestyle:

In terms of lifestyle, among participants consuming three meals a day, overweight accounted for 51.4%, whereas it was 38.3% among those who consumed more than three meals a day. As for the use of fast food, the prevalence of overweight was 60% among those who always or often used it.

The prevalence of overweight was 71% among participants who consumed cooked vegetables daily, while it was 25% among those who consumed them often.

Among those who always ate between meals (snacking), the prevalence of overweight was 53%, while it was 12% among those who rarely or never did so.

Although more than half of the health professionals considered overweight or obesity as a disease, 53% of them are overweight (Table IV).

Discussion

The mean BMI for women was 26.18 (SD \pm 3.77) compared to 25.76 for men (SD \pm 3.62). 37.43% of the population were of normal weight while 62.6% were overweight, of which 16% were obese. This prevalence is higher than that of the general population. This confirms the results of previous research which revealed a higher prevalence of overweight and obesity among nurses than in the general population¹⁹⁻²².

By sex, among the obese, 2/3 were women and 1/3 were men. The study by Dovonou, C. A et al showed high proportions for women and very low proportions for men². These results may be explained by the perception of weight as a sign of good health, wealth and beauty in many African countries²³.

By age, 48% of participants under 39 years of age were overweight. The study by Pobee, R. A et al found

Table IV: Distribution of weight status by lifestyle.

Variables	- 25 Kg/m ²	+ 25 Kg/m ²
Number of meals per day		
Two	5 (7.8)	11 (10.3)
Three	35 (54.7)	55 (51.4)
+ More than three	24 (37.5)	41 (38.3)
Fast food		
Always	8 (12.5)	15 (14)
Often	22 (34.4)	49 (45.8)
Rarely/never	34 (37.4)	43 (40.2)
Consumption of cooked vegetables		
Always	36 (56.2)	76 (71)
Often	23 (35.9)	27 (25.2)
Rarely/never	5 (7.8)	4 (3.7)
Nibbling		
Always	43 (67.2)	57 (53.3)
Often	9 (14.1)	37 (34.6)
Rarely/never	12 (18.8)	13 (12.1)
Perceived overweight		
Illness	43 (67.2)	57 (53.3)
Sign of beauty	9 (14.1)	38 (35.5)
Sign of wealth	12 (18.8)	12 (11.2)

similar results. Indeed, the study recorded a prevalence of 58.3%²⁴.

Similarly, our study showed that overweight decreases with age. While the study by Dovonou, C. A et al showed that obesity increases with age². These differences can be explained by the size of the sample, the different context of the studies and the youth of our population.

According to marital status, almost half of the singles and those with secondary education were overweight²⁰. Our study found that weight load increases with education. This result was consistent with other studies¹⁸. This difference can be explained by the meaning given to obesity in our African and particularly Arab societies. Obesity is generally considered a sign of social well-being.

Obesity is a risk factor for chronic diseases, and a number of studies indicate that overweight and obesity are more common among shift workers than among day workers^{25,26}.

Thus, in our study where paramedics work on a cycle of on-call and off-call, nurses who worked on-call were found to have a 2.029 higher risk of being overweight than those who did not. These results are supported by other studies^{27,28}. This can be explained by the nature of paramedical work, which is shift work for most participants.

Conclusion

Shift work disrupts regular sleep, eating and exercise patterns, which can make it harder to maintain a healthy weight.

Conflict of interest

The authors declare that they have no conflict of interest.

References

1. Organisation Mondiale de la Santé 1997, ed. Obésité: prévention et prise en charge de l'épidémie mondiale; rapport d'une consultation de l'OMS ; [Consultation OMS sur l'Obésité, Genève, 3 - 5 juin 1997]. Genève: Organisation Mondiale de la Santé.; 2003.
2. Dovonou CA, Gounongbe F, Hinson AV, Alassani CA, Attinsounon CA, Tognon FT, et al. Etude Des Facteurs De Risque De L'obésité Chez Le Personnel Du CHUD/Borgou à Parakou (Bénin) en. Published online 2016.
3. Dake FA, Tawiah EO, Badasu DM. Sociodemographic correlates of obesity among Ghanaian women. *Public health nutrition*. 2011;14(7):1285-1291.
4. Olinto MTA, Nacul LC, Gigante DP, Costa JSD, Menezes AMB, Macedo S. Waist circumference as a determinant of hypertension and diabetes in Brazilian women: a population-based study. *Public health nutrition*. 2004;7(5):629-35.
5. St-Pierre J, Lemieux I, Vohl MC, Perron P, Tremblay G, Després JP, Gaudet D. Contribution of abdominal obesity and hypertriglyceridemia to impaired fasting glucose and coronary artery disease. *Am J Cardiol*. 2002 Jul 1;90(1):15-8.
6. Goetzel RZ, Gibson TB, Short ME, Chu BC, Waddell J, Bowen J, et al. A multi-worksites analysis of the relationships among body mass index, medical utilization, and worker productivity. *J Occup Environ Med*. 2010 Jan;52 Suppl 1(Suppl 1):S52-8. 7. Trogdon JG, Finkelstein EA, Hylands T, Dellea PS, Kamal-Bahl SJ. Indirect costs of obesity: a review of the current literature. *Obesity reviews*. 2008;9(5):489-500.
8. Tsai AG, Wadden TA. Treatment of obesity in primary care practice in the United States: a systematic review. *Journal of general internal medicine*. 2009;24(9):1073-9.
9. Organisation Mondiale de la Santé. Obésité et surpoids. Published 2016. Accessed February 8, 2021. <https://www.who.int/fr/news-room/fact-sheets/detail/obesity-and-overweight>
10. Allali F. Evolution des pratiques alimentaires au Maroc. *Integrative Journal of Medical Sciences*. 2017;4(1):70.
11. Haut commissariat au Plan, Royaume du Maroc. Les indicateurs sociaux au Maroc.; 2011:1-253.
12. Ministère de la santé, Maroc. Rapport de l'enquête Nationale Sur Les Facteurs De Risque Communs Des Maladie Non Transmissibles, Steps, 2017-2018.; 2017.
13. Pobee RA, Owusu WB, Plahar WA. The prevalence of obesity among female teachers of child-bearing age in Ghana. *African journal of food, agriculture, nutrition and development*. 2013;13(3).
14. Koffi NM, Sally SJ, Kouame P, Silue K, Nama AD. Faciès de l'hypertension artérielle en milieu professionnel à Abidjan. *Médecine d'Afrique Noire*. 2001;48(6):257-60.
15. Luckhaupt SE, Cohen MA, Li J, Calvert GM. Prevalence of obesity among US workers and associations with occupational factors. *American journal of preventive medicine*. 2014;46(3): 237-48.
16. Han K, Trinkoff AM, Storr CL, Geiger-Brown J. Job stress and work schedules in relation to nurse obesity. *JONA: The Journal of Nursing Administration*. 2011;41(11):488-95.
17. Knutson KL. Sleep duration and cardiometabolic risk: a review of the epidemiologic evidence. *Best practice & research Clinical endocrinology & metabolism*. 2010;24(5):731-43.
18. Dionadjji M, Choua O, Voussia L, Abas O, Saleh A. Prévalence de l'obésité chez les professionnels de la santé de l'Hôpital Général de Référence Nationale à Ndjamen. *HEALTH SCIENCES AND DISEASE*. 2016;17(1).
19. Oueslati I, Khiari K, Riahi T, Ali IH, Mchirgui N, Abdallah NB. Prévalence de l'obésité chez Le personnel paramédical de l'hôpital Charles Nicolle de Tunis (HCN). *Diabetes & Metabolism*. 2012;38:A119.
20. Sharma SV, Upadhyaya M, Karhade M, Baun WB, Perkison WB, Pompeii LA, et al. Are Hospital Workers Healthy?: A Study of Cardiometabolic, Behavioral, and Psychosocial Factors Associated With Obesity Among Hospital Workers. *J Occup Environ Med*. 2016 Dec;58(12):1231-8.
21. Maria MI, Oluwaseyi O. Prevalence of obesity among Nigeria nurses: The Akwa Ibom state experience. *International NGO Journal*. 2010;5(2):045-049.
22. Bogossian FE, Hepworth J, Leong GM, Flaws DF, Gibbons KS, Benefer CA, et al. A cross-sectional analysis of patterns of obesity in a cohort of working nurses and midwives in Australia, New Zealand, and the United Kingdom. *Int J Nurs Stud*. 2012 Jun;49(6):727-38.
23. Amoah AG. Sociodemographic variations in obesity among Ghanaian adults. *Public health nutrition*. 2003;6(8):751-7.
24. Pobee RA, Owusu WB, Plahar WA. The prevalence of obesity among female teachers of child-bearing age in Ghana. *African journal of food, agriculture, nutrition and development*. 2013;13(3).
25. Di Lorenzo L, De Pergola G, Zocchetti C, L'Abbate N, Basso A, Pannacciulli N, Cignarelli M, Giorgino R, Soleo L. Effect of shift work on body mass index: results of a study performed in 319 glucose-tolerant men working in a Southern Italian industry. *Int J Obes Relat Metab Disord*. 2003 Nov;27(11):1353-8.
26. Macagnan J, Pattussi MP, Canuto R, Henn RL, Fassa AG, Olinto MTA. Impact of nightshift work on overweight and abdominal obesity among workers of a poultry processing plant in southern Brazil. *Chronobiology international*. 2012;29(3): 336-43.
27. Peplonska B, Bukowska A, Sobala W. Association of rotating night shift work with BMI and abdominal obesity among nurses and midwives. *PLoS one*. 2015;10(7):e0133761.
28. Zhao I, Bogossian F, Turner C. A cross-sectional analysis of the association between night-only or rotating shift work and overweight/obesity among female nurses and midwives. *Journal of occupational and environmental medicine*. 2012;54(7):834-40.

Comparison of the effect of different in-channel posts on the fracture resistance of simulated immature teeth

Comparación del efecto de diferentes postes en canal sobre la resistencia a la fractura de dientes inmaduros simulados

Alp Şirman , Handan Ersev 

Istanbul University Faculty of Dentistry, Department of Endodontic, Istanbul, Turkey

Corresponding author

Alp Şirman

E-mail: alpsirman@live.com

Received: 20 - I - 2023

Accepted: 22 - II - 2023

doi: 10.3306/AJHS.2023.38.03.132

Abstract

Objective: The aim of this study is to investigate the effects of case-specific nano-ceramic resin composite posts produced using the CAD-CAM system on the fracture resistance of immature teeth, in comparison with that of fiber posts.

Materials-methods: Three groups, each consisting of 20 immature teeth, were included in our study (Group 1: AH Plus paste + gutta-percha. Group 2: Glass fiber post. Group 3: Nano-ceramic resin composite post). Cylindrical assemblies were placed in the Universal test device with the force applied at a speed of 1mm/min at an angle of 45° from the palatal of the sample, and the load at the time of fracture was recorded in Newtons. Then the breaking resistances were noted and analyzed in SPSS v21.0 program. $P < 0.05$ was considered statistically significant.

Results: The difference between the groups was tested with the ANOVA test. Accordingly, a significant difference was found between the groups in breaking strengths ($p < 0.001$). The post-hoc test was performed to analyze which groups these significant results originated from according to the results of the ANOVA test. According to this; The fracture resistance in the second treatment group was 513.04 (95% CI: -682.55 to -343.52) units more resistant than the control group (group 1), and the difference was significant ($p < 0.001$). The fracture resistance in the third treatment group was 620.34 (95% CI: -857.39 to -383.28) units more resistant than the control group (group 1), and the difference was significant ($p < 0.001$). There was a difference between the second group and the third group, but this difference was not statistically significant ($p > 0.05$).

Conclusions: Within the constraints of this study, it can be concluded that when compared to a conventional root canal filling using AH plus and gutta-percha, both glass fiber and nano-ceramic resin composite posts were capable of exerting a reinforcing effect on simulated immature teeth. When dealing with immature teeth, the clinician may be given the choice to use either of these systems from a clinical standpoint.

Key words: Immature permanent tooth, root canal filling, fracture resistance, gutta-percha, CAM/CAD posts, resin composite.

Resumen

Objetivo: El objetivo de este estudio es investigar los efectos de los postes de composite de resina nanocerámica específicos para cada caso, producidos mediante el sistema CAD-CAM, sobre la resistencia a la fractura de dientes inmaduros, en comparación con la de los postes de fibra.

Materiales y métodos: En nuestro estudio se incluyeron tres grupos, cada uno de ellos compuesto por 20 dientes inmaduros (Grupo 1: Pasta AH Plus + gutapercha. Grupo 2: Poste de fibra de vidrio. Grupo 3: Poste de composite de resina nanocerámica). Los conjuntos cilíndricos se colocaron en el dispositivo de prueba universal con la fuerza aplicada a una velocidad de 1 mm/min en un ángulo de 45° desde el paladar de la muestra, y la carga en el momento de la fractura se registró en Newtons. A continuación se anotaron las resistencias a la rotura y se analizaron en el programa SPSS v21.0. $P < 0,05$ se consideró estadísticamente significativo.

Resultados: La diferencia entre los grupos se comprobó con la prueba ANOVA. En consecuencia, se encontró una diferencia significativa entre los grupos en las resistencias a la rotura ($p < 0,001$). Se realizó la prueba post-hoc para analizar de qué grupos procedían estos resultados significativos según los resultados de la prueba ANOVA. Según esto; La resistencia a la fractura en el segundo grupo de tratamiento fue 513,04 (IC 95%: -682,55 a -343,52) unidades más resistente que el grupo de control (grupo 1), y la diferencia fue significativa ($p < 0,001$). La resistencia a la fractura en el tercer grupo de tratamiento fue 620,34 (IC del 95%: -857,39 a -383,28) unidades más resistente que el grupo de control (grupo 1), y la diferencia fue significativa ($p < 0,001$). Hubo una diferencia entre el segundo grupo y el tercero, pero esta diferencia no fue estadísticamente significativa ($p > 0,05$).

Conclusiones: Dentro de las limitaciones de este estudio, se puede concluir que, en comparación con una obturación convencional del conducto radicular mediante AH plus y gutapercha, tanto los postes de fibra de vidrio como los postes de composite de resina nanocerámica fueron capaces de ejercer un efecto de refuerzo en dientes inmaduros simulados. Cuando se trata de dientes inmaduros, el clínico puede optar por utilizar cualquiera de estos sistemas desde un punto de vista clínico.

Palabras clave: Diente permanente inmaduro, obturación radicular, resistencia a la fractura, gutapercha, postes CAM/CAD, composite de resina.

Introduction

To date, the effect of various filling materials has been investigated to increase the fracture resistance of young permanent teeth with root canal treatment¹. Studies have shown that filling materials that can adhere to root dentin strengthen root canal-treated roots². Gutta-percha, which is accepted as the gold standard in root canal treatment, does not adhere to dentin and has been shown to not strengthen the tooth³. For this purpose, it has been suggested that the canal sealers used with gutta-percha can strengthen the teeth as they can adhere to the dentin. Based on this idea, in our study, AH 26 and Endoplus, which are resin-based canal-filling pastes, were applied together with gutta-percha in separate groups to evaluate the fracture resistance of the teeth².

Again, in studies on fracture resistance to date, it has been shown that canal-filling materials close to the elasticity module of dentin increase the fracture resistance of teeth. Based on this information, glass fiber-reinforced composite posts, which were shown to have a modulus of elasticity close to that of dentin, were used in our study to evaluate the fracture resistance of the teeth^{4,5}.

Teeth treated with apexification methods remain structurally weak due to thin root canal walls and are prone to cervical horizontal or oblique fractures. Often, teeth suffering from such fractures cannot be repaired and must be extracted. Therefore, different methods are described for the internal reinforcement of these teeth to support weak tooth structure and reduce the risk of fracture⁶⁻⁸. The most successful methods are based on adhesive techniques, where composite resin and reinforcement materials such as fiber-reinforced composite posts (FRC-post) are bonded to root canal dentin. Numerous studies have been conducted to evaluate the bonding properties of these materials in mature teeth. However, in immature teeth, conditions differ due to the large root canal diameter, which often exceeds the post diameter of commercially available FRC posts, resulting in a mismatched post fit. Little is known about the effect of post fit on the bonding properties of conventional and adhesively bonded FRC posts^{9,10}.

CAD/CAM technology has facilitated the production of personalized prostheses in a single session in today's dentistry. The first feldspathic blocks were used in the use of blocks in CAD/CAM systems in dentistry. However, different blocks have been produced by the combination of other materials due to their lack of mechanical properties. It has been reported that posts produced using CAD/CAM systems can increase the resistance of the tooth against fracture^{2,9}.

The aim of our research is to comparatively investigate the effects of case-specific nano-ceramic resin composite fiber posts produced using the CAD-CAM system on the

fracture resistance of immature teeth.

Materials and methods

Study design

A total of 60 freshly extracted maxillary anterior incisors were kept in 0.1% thymol solution until the study. The coronal part of the teeth was removed 2 mm coronal of the enamel-cementum junction. The length of the teeth was adjusted to 13±1 mm by cutting from the apically. In order to simulate immature teeth, Peezo reamers 1 to 6 were used in the canal and then Peezo reamer no. 6 was used 1 mm from the apical. After shaping, the channels were washed with 5 ml of 5.25% sodium hypochlorite, 5 ml of distilled water and 5 ml of 17% EDTA for 1 minute, and the smear layer was removed. In order to imitate the clinical conditions, the canals will be filled with calcium hydroxide, the access cavities were closed with temporary restoration material (Cavit, 3M ESPE, Seefeld, Germany) and the samples were kept in a 100% humidity environment at 37°C for 1 week. At the end of one week, the temporary restoration and the calcium hydroxide paste in the canal were removed by sonic activation of 5.25% sodium hypochlorite. In the last wash, 5 ml of 17% EDTA and then 5 ml of distilled water were used. An apical plug was created using MTA Angelus White (Angelus, Londrina, Brazil) on the apical 5 mm of the canals established with paper cones. Then, the samples were kept for 24 hours at 37°C in a 100% humidity environment for the MTA to harden.

Study groups

The teeth were randomly divided into 3 different groups, with 20 samples in each group.

Group 1: AH Plus paste + gutta-percha: The canals were filled up to the apical plug by lateral compaction using AH Plus paste (Dentsply De Trey, Switzerland). The canal filling was removed up to 1 mm below the coronal level and the cavity was closed with composite filling material (Filtek Z250; 3M ESPE, USA).

Group 2: Glass fiber post: The post space was prepared in the canal up to the apical plug with 3 Rely X post drills (3M ESPE, Seefeld, Germany). Resin-based luting cement (Rely X U200 Automix; 3M ESPE, Seefeld, Germany) was applied to the post cavity according to the manufacturer's instructions. Then #3 Rely X fiber post (3M ESPE, Seefeld, Germany) was placed with finger pressure. After removing the residual cement, a light gun was used for 40 seconds. For example, the piece of post above the coronal level was removed with a high speed rotating diamond bur.

Group 3: Nano-ceramic resin composite post: After the post cavity was prepared as in Group 2, the measurement of the cavity was taken. Using 3M Lava Ultimate blocks (3M ESPE, Seefeld, Germany), a suitable post was prepared with the help of CAD-CAM device. Adhesion of

the post was carried out using the cement and method in Group 2. Afterward, the samples were kept in a 100% humidity environment at 37°C until the fracture test.

Measurement of fracture resistance

Before the fracture test, the periphery of the root was covered with 0.2-0.3 mm thick polyvinylsiloxane impression material (ColteneWhaledent AG, Altstätten, Switzerland) to simulate the periodontal ligament. Then, self-curing acrylic (Imicryl, Konya, Turkey) was poured into cylinders with a length and diameter of 20 mm, and the sample was placed vertically in the acrylic up to 2 mm below the enamel-cement level. Cylindrical assemblies will be placed in the Universal test device such that the force applied at a speed of 1mm/min comes at an angle of 45° (3) from the palatal of the example, and the load at the time of breakage is recorded in Newtons.

Inclusion criteria

Among the teeth planned to be extracted for various reasons (periodontal reasons, inability to restore the tooth, etc.), the maxillary anterior and lateral incisors were included in our study. The patients included in the study consisted of patients over the age of 18, consisting of both boys and girls.

Exclusion criteria

Teeth with defects such as resorption, cracks, and fractures, teeth with previous root canal treatment, teeth with calcification in the root canal, and teeth with a difference of more than 20% between the ratio of buccolingual and mesiodistal diameters at the enamel-cementum junction, teeth without single canal and teeth with canal inclination greater than 10° were excluded.

Statistical analysis

Statistical analysis was performed for patient data, including descriptive statistics, frequency, and other characteristics for all items. Continuous data are written as mean ± standard deviation. Continuous variables were analyzed with the Shapiro-Wilk and Kolmogorov-Smirnov

tests to determine whether the data had a normal distribution. Continuous and normally distributed variables were compared using Student's T-test and ANOVA. Non-parametric tests were chosen when the data did not fit the normal distribution. Analyzes were performed using SPSS Statistics for Windows, Version 21.0 (IBM Corp., Armonk, NY, USA). All p values were bidirectional and $p \leq 0.05$ was considered statistically significant.

Results

Three groups (total of 60 teeth) each consisting of 20 immature teeth were included in our study (Group 1: AH Plus paste + gutta-percha. Group 2: Glass fiber post. Group 3: Nano-ceramic resin composite post). Accordingly, there was a significant difference in fracture resistance between the groups ($p < 0.001$) (Table I). Figure 1 imagines the breaking resistances and confidence intervals of the groups.

The post-hoc test was performed to analyze which groups these significant results originated from according to the results of the ANOVA test. According to this; The fracture resistance in the second treatment group was

Figure 1: Fracture resistances and confidence intervals.

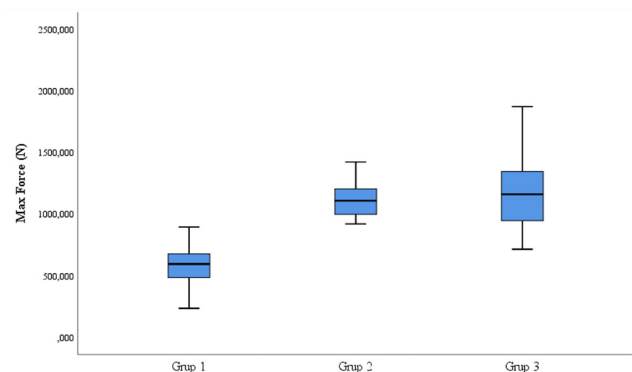

Table I: Measurement of fracture resistances by treatment groups.

	N	Mean	Std. deviation	Std. error	Minimum	Maximum	p-value
Group 1	20	597,23	169,18	37,83	236,72	982,66	<0,001*
Group 2	20	1110,27	258,38	57,78	518,28	1609,53	
Group 3	20	1217,57	391,50	87,54	715,94	2153,13	
Total	60	975,02	393,19	50,76	236,72	2153,13	

*ANOVA test.

Table II: Post-hoc analysis results.

		Mean difference	Std. error	p-value	95% Confidence Interval	
					Minimum	Maximum
Group 1	Group 2	-513,04	69,06	0,00*	-682,55	-343,52
	Group 3	-620,34	95,37	0,00*	-857,39	-383,28
Group 2	Group 1	513,04	69,06	0,00*	343,52	682,55
	Group 3	-107,30	104,89	0,57*	-364,71	150,11
Group 3	Group 1	620,34	95,37	0,00*	383,28	857,39
	Group 2	107,30	104,89	0,57*	-150,11	364,71

*Post-hoc Tukey test.

513.04 (95% CI: -682.55 to -343.52) units more resistant than the control group (group 1), and the difference was statistically significant ($p < 0.001$). The fracture resistance in the third treatment group was 620.34 (95% CI: -857.39 to -383.28) units more resistant than the control group (group 1), and the difference was statistically significant ($p < 0.001$). There was a difference between the second group and the third group, but this difference was not statistically significant ($p > 0.05$) (Table II).

Discussion

Since immature teeth have not completed their development yet, their root length is short, root dentin walls are very thin, and root tips are open. For these reasons, immature permanent teeth with root canal treatment are very prone to fracture. Therefore, most of the studies aimed at strengthening the roots have aimed to strengthen immature teeth^{3,11,12}. This study was planned to investigate which material is more effective in increasing the fracture resistance of immature teeth. In our study, it was preferred to use extracted human immature teeth with the same morphological and structural features in order to ensure that the results are compatible with clinical conditions.

The demographic group most affected by impact-related dental injuries are youth and children aged 8-12¹³. These injuries can cause pulp necrosis in immature permanent teeth with insufficient root development and, as a result, thin and fragile root walls. When the apexification method using calcium hydroxide is applied, the amount of success achieved with endodontic treatment in these cases is very high¹⁴. Andreasen et al.¹³ concluded that leaving a calcium hydroxide dressing in the root canal for a long time damaged the root structure. For this reason, thin root walls, especially in the cervical region, constitute a very important clinical problem. This is especially true for the upper back teeth. In a second event, the teeth will be more prone to root fractures and these teeth will be more difficult to maintain. Therefore, it is imperative to use supplements for these relatively weak roots. Several different types of materials have been used to achieve the goal of making endodontically treated teeth more resistant to damage.

In a study comparing the fracture resistances of teeth restored with various types of posts, Akkayan and Gulmez found quartz fiber posts significantly outperformed the other three groups in terms of fracture resistance¹⁵. It was discovered that the statistically similar fracture resistances of teeth were restored with glass fiber and zirconia posts^{15,16}. The fracture resistances of the glass fiber, quartz fiber, and zirconia posts were all significantly higher than those of the control group, which is where the results of the current study diverge from theirs. This finding may be explained by the two investigations' use of different study designs. The aforementioned authors

chose to use standard cores and metal crowns rather than simulating immature teeth or applying force directly to the tooth, which could have affected the results.

The resistance to compression of weak roots subjected to various reconstruction protocols with glass fiber posts was assessed by Zogheib et al.¹⁷ Since the type of fracture that occurred made it possible to repair the remaining dental structure, it was suggested that the incremental technique be used because none of the root reconstruction methods with intraradicular posts improved root strength. The two studies' differences in the types of teeth used as controls can be seen. Although nonweakened teeth were used in the study by Zogheib et al., weakened teeth were preferred in the present study and the experimental groups¹⁷.

The findings of the present study suggest that commercially available tooth-colored post systems have a similar ability to reinforce developing teeth with structural problems. Although the choice must take into account the involved tooth's location, esthetic needs, and degree of coronal structure loss, it appears that this choice shouldn't raise many concerns when compared to a simple root canal filling because there doesn't appear to be much of a difference in this parameter when it comes to developing teeth. As with all in vitro studies, the results of the present study should definitely be interpreted cautiously, despite giving a general idea about the behavior of various post systems that are currently available. Variables like occlusion that is unique to each person, mastication habits, parafunctions, and the structure of the alveolar bone may all contribute to varying clinical outcomes. Additionally, resistance analysis after thermocycling, flexural strength and fatigue resistance values extended over a longer time period, and resistance analysis may produce different results. It will be possible to clearly understand tooth-colored post systems intended to be used for the reinforcement of developing teeth from future studies evaluating these factors.

Conclusions

Within the constraints of this study, it can be concluded that when compared to a conventional root canal filling using AH plus and gutta-percha, both glass fiber and nano-ceramic resin composite posts were capable of exerting a reinforcing effect on simulated immature teeth. When dealing with immature teeth, the clinician may be given the choice to use either of these systems from a clinical standpoint.

Funding

No

Conflict of interest

The authors declare no conflict of interest

References

1. Stuart CH, Schwartz SA, Beeson TJ. Reinforcement of immature roots with a new resin filling material. *J Endod.* 2006;32(4):350-3.
2. Hammad M, Qualtrough A, Silikas N. Effect of new obturating materials on vertical root fracture resistance of endodontically treated teeth. *J Endod.* 2007;33(6):732-6.
3. Shanahan DJ, Duncan HF. Root canal filling using Resilon: a review. *Br Dent J.* 2011;211(2):81-8.
4. Trope M. Treatment of the immature tooth with a non-vital pulp and apical periodontitis. *Dent Clin.* 2010;54(2):313-24.
5. Torabinejad M, Nosrat A, Verma P, Udochukwu O. Regenerative endodontic treatment or mineral trioxide aggregate apical plug in teeth with necrotic pulps and open apices: a systematic review and meta-analysis. *J Endod.* 2017;43(11):1806-20.
6. Flanagan TA. What can cause the pulps of immature, permanent teeth with open apices to become necrotic and what treatment options are available for these teeth. *Aust Endod J.* 2014;40(3):95-100.
7. Akleyin E, Polat Y, Yavuz Y. Three-Year Dentition Follow-up of a Paediatric Case with Malignant Infantile Osteopetrosis: A Review of the Literature. *J Clin Trials Exp Investig.* 2022;1(2):41-8.
8. Polat Y, Çelenk S. Overview of current fluorine-free remineralization materials and methods as an alternative to topical fluoride: An up-to-date. *J Clin Trials Exp Investig.* 2022;1(3):75-85.
9. Spitznagel FA, Boldt J, Gierthmuehlen PC. CAD/CAM ceramic restorative materials for natural teeth. *J Dent Res.* 2018;97(10):1082-91.
10. Hargreaves KM, Diogenes A, Teixeira FB. Treatment options: biological basis of regenerative endodontic procedures. *Pediatr Dent.* 2013;35(2):129-40.
11. Skorulska A, Piszko P, Rybak Z, Szymonowicz M, Dobrzyński M. Review on polymer, ceramic and composite materials for cad/cam indirect restorations in dentistry—Application, mechanical characteristics and comparison. *Materials.* 2021;14(7):1592.
12. Al-Haj Husain N, Özcan M, Molinero-Mourelle P, Joda T. Clinical performance of partial and full-coverage fixed dental restorations fabricated from hybrid polymer and ceramic CAD/CAM materials: A systematic review and meta-analysis. *J Clin Med.* 2020;9(7):2107.
13. Andreasen JO, Farik B, Munksgaard EC. Long-term calcium hydroxide as a root canal dressing may increase risk of root fracture. *Dent Traumatol.* 2002;18(3):134-7.
14. Marion J, Pavan K, Arruda M, Nakashima L, Morais CAH. Chlorhexidine and its applications in Endodontics: a literature review. *Dent Press Endod Internet.* 2013;3(3):36-54.
15. Akkayan B, Gülmez T. Resistance to fracture of endodontically treated teeth restored with different post systems. *J Prosthet Dent.* 2002;87(4):431-7.
16. Bogen G, Kuttler S. Mineral trioxide aggregate obturation: a review and case series. *J Endod.* 2009;35(6):777-90.
17. Zogheib LV, Saavedra Gde S, Cardoso PE, Valera MC, Araújo MA. Resistance to compression of weakened roots subjected to different root reconstruction protocols. *J Appl Oral Sci.* 2011 Nov-Dec;19(6):648-54.

Vitamin D has no significant associations with high sensitivity C reactive protein and tumor necrosis factor-alpha in adults with prediabetes

La vitamina D no tiene asociaciones significativas con la proteína C reactiva de alta sensibilidad y el factor de necrosis tumoral alfa en adultos con prediabetes

**Ibrahim Faisal¹ , Md Shahed Morshed² , Tahniyah Haq³ , Shahjada Selim³ ,
Md Habibul Ghani⁴ , Muhammad Abul Hasanat⁵ , Md Fariduddin⁵ **

1. Consultant (Endocrinology), Indira Gandhi Memorial Hospital, Kanbaa Aisa Rani Higon, Male'-20402, Republic of Maldives
2. Emergency Medical Officer, Kurmitola General Hospital, Dhaka, Bangladesh
3. Assistant Professor, Department of Endocrinology, Bangabandhu Sheikh Mujib Medical University, Dhaka, Bangladesh
4. Junior Consultant, Jinjira 20 beded Hospital, Keranigonj, Dhaka, Bangladesh
5. Professor, Department of Endocrinology, Bangabandhu Sheikh Mujib Medical University, Dhaka, Bangladesh

Corresponding author

Md Shahed Morshed
E-mail: shahedk62@gmail.com

Received: 22 - I - 2023

Accepted: 24 - II - 2023

doi: 10.3306/AJHS.2023.38.03.137

Abstract

Objective: Both vitamin D deficiency (VDD) and meta-inflammation are common in patients with prediabetes. The aim of this study was to see the association of vitamin D with inflammatory markers: high-sensitivity C reactive protein (hs-CRP) and tumor necrosis factor-alpha (TNF- α) in adults with prediabetes.

Methods: This cross-sectional study included 115 newly detected adults with prediabetes [age (years): 36.37 \pm 10.06, m/f: 23/92, BMI (kg/m²): 28.81 \pm 4.34]. Clinical information was collected and blood was taken in a fasting state to measure vitamin D by high-performance liquid chromatography, hs-CRP by turbidimetric/immunoturbidimetric, and TNF- α by ELISA method.

Results: About 46.09% had VDD (<20 ng/mL), 33.04% had vitamin D insufficiency (20-29.9 ng/mL) and 60.87% had high cardiovascular risk (hs-CRP \geq 3.0 mg/L) and 92.17% had high inflammatory status (TNF- α \geq 2.53 pg/mL). Both hs-CRP and TNF- α levels were statistically similar across the vitamin D status (NS for both). Regression analyses showed that both hs-CRP and TNF- α had no predictive associations with either vitamin D level or status in adults with prediabetes (NS for both).

Conclusion: Vitamin D had no significant association with hs-CRP and TNF- α in adults with prediabetes.

Key words: vitamin D, high sensitivity C reactive protein, tumor necrosis factor-alpha, prediabetes.

Resumen

Objetivo: Tanto la deficiencia de vitamina D (VDD) como la metainflamación son comunes en pacientes con prediabetes. El objetivo de este estudio fue ver la asociación de la vitamina D con los marcadores inflamatorios: proteína C reactiva de alta sensibilidad (hs-CRP) y factor de necrosis tumoral-alfa (TNF- α) en adultos con prediabetes.

Métodos: Este estudio transversal incluyó a 115 adultos recién detectados con prediabetes [edad (años): 36,37 \pm 10,06, m/f: 23/92, IMC (kg/m²): 28,81 \pm 4,34]. Se recogió información clínica y se extrajo sangre en ayunas para medir la vitamina D por cromatografía líquida de alto rendimiento, la hs-CRP por turbidimetría/inmunoturbidimetría y el TNF- α por el método ELISA.

Resultados: Alrededor del 46,09% tenía VDD (<20 ng/mL), el 33,04% tenía insuficiencia de vitamina D (20-29,9 ng/mL) y el 60,87% tenía alto riesgo cardiovascular (hs-CRP \geq 3,0 mg/L) y el 92,17% tenía un estado inflamatorio alto (TNF- α \geq 2,53 pg/mL). Tanto los niveles de hs-CRP como de TNF- α no mostraron diferencias estadísticamente significativas según el estado de la vitamina D. Los análisis de regresión mostraron que tanto la hs-CRP como el TNF- α no tenían asociaciones predictivas con el nivel o el estado de la vitamina D en adultos con prediabetes (NS para ambos).

Conclusión: La vitamina D no tuvo una asociación significativa con la PCR-as y el TNF- α en adultos con prediabetes.

Palabras clave: vitamina D, proteína C reactiva de alta sensibilidad, factor de necrosis tumoral-alfa, prediabetes.

Introduction

The health care burden of diabetes mellitus (DM) is progressively increasing due to its rising prevalence throughout the whole world¹. One of the strategies is to prevent its progression from its preceding stage-prediabetes. Both of the conditions are characterized by chronic low grade inflammation, β cell dysfunction and insulin resistance. Several circulating cytokines including tumor necrosis factor α (TNF- α) and C reactive protein (CRP) are found to be elevated in DM and prediabetes^{2,3}. This meta-inflammation may contribute to insulin resistance in muscle and adipose tissue leading to the development of glucose intolerance, endothelial dysfunction, and ultimately atherosclerotic cardiovascular disease⁴.

TNF- α is secreted from the monocyte-macrophage system as well as from adipose tissue. The expression in adipocytes contributes to insulin resistance via negative effects on insulin signaling and induction of lipolysis⁵. On the other hand, it also promotes the synthesis of CRP from the liver which is an acute phase protein and marker of inflammation. High-sensitivity CRP (hs-CRP) measures a very low level of inflammation and it is one of the best predictors of cardiovascular risk⁶.

Recent studies also suggest that most of the cells of the immune system express receptors for vitamin D. This is hypothesized that vitamin D may act as an immune modulator and interfere with systemic inflammation and reduce insulin resistance⁷. Besides, vitamin D may play a role in insulin secretion from pancreatic β -cells⁸. Vitamin D deficiency (VDD) is very common even in areas with plenty of sunshine⁹. Its treatment is also easy and cost-effective. Although controversial, it was observed in several meta-analyses that vitamin D might prevent DM progression from prediabetes^{10,11}. One of the possible mechanisms may be a reduction of inflammatory markers by vitamin D supplementation¹². However, data regarding the association between vitamin D and inflammatory markers in adults with prediabetes are controversial. Moreover, there is very limited data from Bangladeshi population regarding their association in adults with prediabetes. The aim of this study was to see the association of vitamin D with hs-CRP and TNF- α in adults with prediabetes.

Methods

This cross-sectional study included 115 newly detected adults with prediabetes consecutively by convenient sampling from the department of Endocrinology of a University hospital over a period of one and half years (January, 2018 to June 2019). The sample size was calculated from the following formula: $n = \frac{Z^2 \times p \times (1-p)}{d^2}$. Here, $Z = 1.96$ at a 95% confidence level, $p =$ prevalence of VDD in prediabetes = 0.7325, and $d =$ at 10% margin of error = 0.1.¹³ The minimum number of

samples to be studied was 76. As facilities permitted, 115 participants with prediabetes were included. Patients with a history of intake of vitamin D or calcium within 120 days of enrollment, and taking any medications that may alter vitamin D metabolism (glucocorticoids, oral contraceptives, anticonvulsants, anti-Koch, etc.) were excluded. Similarly, patients having known endocrine disorders (hyperthyroidism, hyperparathyroidism, Cushing syndrome, etc.) or malabsorption syndrome affecting vitamin D metabolism, pregnant and lactating mother, any acute or chronic disorders related to inflammation (history of fever, autoimmune disease, chronic heart failure, chronic kidney disease, chronic liver disease, malignancy, polycystic ovary syndrome, etc.) were also excluded. Prior to beginning, the approval of the study protocol and ethical clearance was taken from the institutional review board of the University. Informed written consent was taken from all the study participants.

Patients' relevant history and physical findings were collected in a semi-structured questionnaire. Venous blood was collected in a fasting state, centrifuged, and preserved in -200C until assay. Vitamin D (25-hydroxyvitamin D3) was measured by high-performance liquid chromatography, hs-CRP by turbidimetric/immunoturbidimetric method (Abbott Architect Plus), and TNF- α by ELISA (DRG Instruments GmbH, Germany) method. All the collected data were immediately verified by a senior author, and there were no missing data.

Prediabetes was diagnosed according to American Diabetes Association, 2018 criteria for non-pregnant adults¹⁴. Vitamin D status was classified by the Endocrine Society's clinical practice guideline, 2011 into sufficiency, insufficiency, and deficiency by vitamin D levels of 30 and 20 ng/mL respectively¹⁵. The hs-CRP status was categorized into low, moderate, and high cardiovascular risk with the cut-off value of one and three mg/L respectively¹⁶. The cut-off to define inflammatory status by TNF- α was 2.53 pg/mL.¹⁷ General and central obesity were categorized according to Asian criteria.¹⁸ Smoking status and physical activity level were defined as per the Mayo clinic and the international physical activity questionnaire respectively.^{19,20}

Data were analyzed by SPSS software version 22.0. Qualitative data were expressed in frequency (percentages). The distribution of quantitative variables was checked by the Shapiro-Wilk test. Normally distributed data were expressed in mean \pm standard deviation (SD) and skewed data were expressed in median (inter-quartile range, IQR). Comparison among the different statuses of vitamin D was done by Pearson's chi-square or One-way ANOVA or Kruskal Wallis one-way ANOVA test as appropriate. Correlations of vitamin D with hs-CRP and TNF- α were done by Spearman's correlation test. Multivariate linear regression analysis was done to see the predictive association of hs-CRP

and TNF- α with vitamin D. At last, univariate multinomial logistic regression analysis was done to see the predictive associations of hs-CRP and TNF- α categories with vitamin D status (deficiency vs. not deficiency).

Results

The characteristics of the study population according to vitamin D status are shown in **table I**. Around half of the patients with prediabetes had VDD and one-third had

vitamin D insufficiency according to Endocrine Society's criteria. All the baseline characteristics as well as hs-CRP and TNF- α were statistically similar among the vitamin D status (NS for all).

Around 60.87% of the study participants had high CV risk according to hs-CRP levels (cut-off of 3.0 mg/L) and 92.17% had high inflammatory status by TNF- α levels (cut-off of 2.53 pg/mL). However, Vitamin D levels were statistically similar according to both categories (NS for both) (**Figure 1** and **Figure 2**).

Figure 1: Serum vitamin D levels according to cardiovascular risk category by hs-CRP levels.

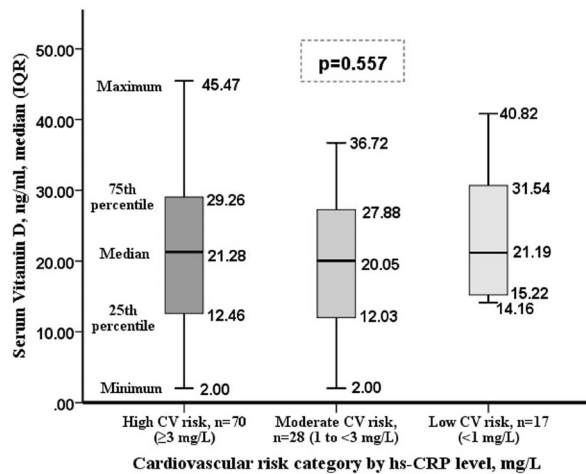

Kruskal-Wallis one way ANOVA test was done

Figure 2: Serum vitamin D levels according to TNF- α category.

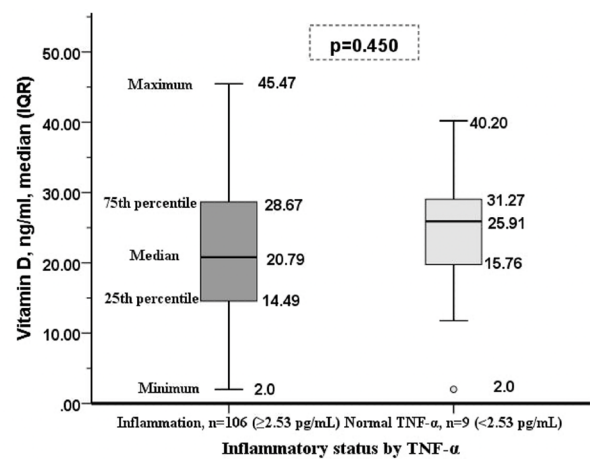

Mann-Whitney U test was done

Table I: Characteristics of the study population with vitamin D status (N=115).

Variables	Vitamin D status			p
	Deficiency	Insufficiency	Sufficiency	
Frequency (%)	53 (46.09)	38 (33.04)	24 (20.87)	
Age, years	37.32 \pm 10.22	35.03 \pm 9.38	36.42 \pm 10.89	0.566
Female sex	38 (71.7)	32 (84.2)	22 (91.7)	0.106
Smoking status				
Current smoker	3 (5.7)	2 (5.3)	1 (4.2)	0.966
Past smoker	8 (15.1)	4 (10.5)	2 (8.3)	
Nonsmoker	42 (79.2)	32 (84.2)	21 (87.5)	
Physical activity level				
Low	24 (45.3)	15 (39.5)	17 (70.8)	0.061
Moderate	27 (50.9)	23 (60.5)	7 (29.2)	
High	2 (3.8)	0 (0.0)	0 (0.0)	
Family history of DM	38 (71.7)	19 (50.0)	13 (54.2)	0.080
Daily sunlight exposure between 11 am to 1 pm (minutes)	0.0 (0.0, 27.5)	10.0 (0.0, 30.0)	0.0 (0.0, 13.75)	0.183
Sunlight exposure of body surface area $\geq 20\%$	11 (20.8)	10 (26.3)	5 (20.8)	0.840
Use of sunscreen	2 (3.8)	2 (5.3)	1 (4.2)	1.00
Vitamin D containing food intake at least 1 serving/day				
Egg > 3 days/week	17 (32.1)	9 (23.7)	4 (16.7)	0.317
Large fish > 3 days/week	23 (43.4)	20 (52.6)	9 (37.5)	0.492
BMI category				
Optimal (18.5 - 22.9)	3 (5.7)	2 (5.3)	3 (12.5)	0.405
Overweight (23.0 - 24.9)	10 (18.9)	3 (7.9)	2 (8.3)	
Obese (≥ 25)	40 (75.5)	33 (86.8)	19 (79.2)	
Centrally obese (M ≥ 90 , F ≥ 80)	48 (90.6)	36 (94.7)	22 (91.7)	0.802
Systolic BP, mm-Hg	118.49 \pm 14.40	115.32 \pm 13.87	120.13 \pm 17.07	0.415
Diastolic BP, mm-Hg	80.09 \pm 10.08	79.29 \pm 8.85	82.25 \pm 11.41	0.517
hs-CRP, mg/L	4.17 (1.73, 9.60)	3.23 (1.97, 6.53)	3.65 (1.43, 6.68)	0.752
TNF- α , pg/mL	16.40 (8.58, 42.25)	12.75 (7.10, 30.72)	8.94 (6.49, 22.47)	0.105

Data were expressed in mean \pm SD or median (IQR) or frequency (%) as appropriate
One-way ANOVA or Kruskal-Wallis one-way ANOVA or chi-square test was done as appropriate

Vitamin D significantly and inversely correlated with TNF- α [$r = -0.204$, $p = 0.029$]. However, in multivariate linear regression analysis, none of the independent variables including hs-CRP and TNF- α had a predictive association with vitamin D (NS for both) (**Table II**).

Univariate logistic regression analysis also showed insignificant predictive associations of hs-CRP and TNF- α categories with vitamin D status (NS for both) (**Table III**).

Discussion

This cross-sectional study included 115 adults with prediabetes to see the association of vitamin D with inflammatory markers: hs-CRP and TNF- α . This study did not find any significant association between vitamin D with either hs-CRP or TNF- α in adults with prediabetes.

We found that around half of the adults with prediabetes had VDD. The association of low vitamin D levels with prediabetes was found in several large population-based studies^{21,22}. Inadequate sunlight exposure time, exposure of the body surface area to sunlight along with low intake of vitamin D containing food intake might be the possible causes of VDD in our study population. Similarly, we also found more than 90% of patients had high inflammatory status and more than 60% had high CV risk. Although, the role of low-grade inflammation as a precipitating factor of the development of DM is questionable, their association is almost a constant finding²³.

We did not find a significant association of both hs-CRP and TNF- α with vitamin D among adults with prediabetes. Zhang et al. (2017) also did not find any significant association between vitamin D and TNF- α in adults with

prediabetes. However, they found a significant inverse association between vitamin D with hs-CRP²⁴. On the other hand, Beilfuss et al. (2017) did not find a significant change in hs-CRP levels by vitamin D supplementation over 5 years²⁵. The conflicting result indicates that several confounding factors may be responsible for the alteration of these inflammatory markers or that the association has no significant importance²⁵.

Although observational studies found significant associations of vitamin D with inflammation, randomized trials mostly failed to show improvement in inflammatory status. One author suggested that this might be due to the fact that VDD is a marker of ill health rather than the cause of inflammation. Rather, inflammation may cause VDD²⁶. Another possibility is that the association is found in diseases with higher inflammatory status rather than a relatively low-grade inflammatory status associated with prediabetes or in patients with low vitamin D levels^{27,28}.

This study has several limitations. The sample size was small and we could not take the control population.

In conclusion, despite a higher proportion of VDD and inflammatory status, there was no significant association of vitamin D with inflammation in adults with prediabetes.

Acknowledgments: We are grateful to the Center for Advanced Research in Sciences, Dhaka University and the Department of Biochemistry, BSMMU for their technical support.

Financial support: We obtained a partial grant from University Research and Development, BSMMU, and Beximco Pharmaceuticals Limited, Bangladesh for the measurement of vitamin D.

Ethical approval: The ethical clearance of the study protocol was taken from the institutional review board of Bangabandhu Sheikh Mujib Medical University (Protocol no: BSMMU/2018/4827, date: 06/05/2018)

Conflict of interest

The authors declare no conflict of interest

Table II: Correlation and linear regression analysis of vitamin D as dependent variable.

Determinants of 'r'	Spearman's correlation		Multivariate linear regression	
	r	p	β	p*
hs-CRP, mg/L	-0.062	0.510	-0.078	0.435
TNF- α , pg/mL	-0.204	0.029	-0.178	0.068
Constant			B=15.997	0.188

r, correlation co-efficient; β , linear regression co-efficient

*adjusted for age, BMI, WC, systolic and diastolic blood pressure

Table III: Multinomial logistic regression analysis of vitamin D status as dependent variable.

Independent variable	Groups	Univariate regression analysis	
		Odds ratio (95% CI)	p
hs-CRP	Low risk (<1 mg/L)	1	
	Moderate risk (1 to <3 mg/L)	1.203 (0.411, 3.522)	0.736
	High risk (≥ 3 mg/L)	1.429 (0.423, 4.826)	0.566
	Constant	B= -0.357	0.469
TNF- α	Normal (<2.53 pg/mL)	1	
	Inflammatory status (≥ 2.53 pg/mL)	1.786 (0.424, 1.517)	0.429
	Constant	B= -0.693	0.327

References

- International Diabetes Federation. IDF Diabetes Atlas, 9th edition, Brussels, Belgium 2019. <https://www.diabetesatlas.org>.
- Tsalamandris S, Antonopoulos AS, Oikonomou E, Papamikroulis GA, Vogiatzi G, Papaioannou S, et al. The role of inflammation in diabetes: current concepts and future perspectives. *Eur Cardiol* 2019;14(1):50-9. doi: 10.15420/ecr.2018.33.1.
- Wang Z, Shen X-H, Feng W-M, Ye G, Qiu W, Li Bo. Analysis of inflammatory mediators in prediabetes and newly diagnosed type 2 diabetes patients. *J Diabetes Res* 2016; 2016:10p. <https://doi.org/10.1155/2016/7965317>.
- Berg AH, Scherer PE. Adipose tissue, inflammation, and cardiovascular disease. *Circ Res*. 2005;96(9):939-49. doi: 10.1161/01.RES.0000163635.62927.34.
- Qi C, Pekala PH. Tumor necrosis factor-alpha-induced insulin resistance in adipocytes. *Proc Soc Exp Biol Med*. 2000;223(2):128-35. doi: 10.1046/j.1525-1373.2000.22318.x.
- Ridker PM, Hennekens CH, Buring JE, Rifai N. C-reactive protein and other markers of inflammation in the prediction of cardiovascular disease in women. *N Engl J Med*. 2000;342(12):836-43. doi: 10.1056/NEJM200003233421202.
- Sassi F, Tamone C, D'Amelio P. Vitamin D: nutrient, hormone, and immunomodulator. *Nutrients* 2018;10(11):1656. doi: 10.3390/nu10111656.
- Alvarez JA, Ashraf A. Role of vitamin D in insulin secretion and insulin sensitivity for glucose homeostasis. *Int J Endocrinol* 2010;2010:351385. doi: 10.1155/2010/351385.
- Hossain MF, Shahed-Morshed M, Fariduddin M, Haq T, Selim S, Hasanat MA, et al. Vitamin D status in different categories of glucose intolerance in Bangladeshi adults. *Int J Diabetes Endocrinol* 2021;6(1):24-30. doi: 10.11648/j.ijde.20210601.15.
- Zhang Y, Tan H, Tang J, Li J, Chong W, Hai Y, et al. Effects of vitamin D supplementation on prevention of type 2 diabetes in patients with prediabetes: a systematic review and meta-analysis. *Diabetes Care* 2020;43(7):1650-8. doi: 10.2337/dc19-1708.
- Mirhosseini N, Vatanparast H, Mazidi M, Kimball SM. Vitamin D supplementation, glycemic control, and insulin resistance in prediabetics: a meta-analysis. *J Endocr Soc* 2018;2(7):687-709. doi: 10.1210/je.2017-00472.
- Calton EK, Keane KN, Newsholme P, Soares MJ. The impact of vitamin D Levels on inflammatory status: a systematic review of immune cell studies. *PLoS One*. 2015;10(11):e0141770. doi: 10.1371/journal.pone.0141770.
- Dutta D, Maisnam I, Shrivastava A, Sinha A, Ghosh S, Mukhopadhyay P, et al. Serum vitamin-D predicts insulin resistance in individuals with prediabetes. *Indian J Med Res* 2013;138(6):853-60. Available from: <https://www.ijmr.org.in/text.asp?2013/138/6/853/126830>.
- American Diabetes Association. 2. Classification and Diagnosis of Diabetes: Standards of Medical Care in Diabetes-2018. *Diabetes Care*. 2018 Jan;41(Suppl 1):S13-S27. doi: 10.2337/dc18-S002.
- Holick MF, Binkley NC, Bischoff-Ferrari HA, Gordon CM, Hanley DA, Heaney RP, et al. Evaluation, treatment, and prevention of vitamin D deficiency: an Endocrine Society clinical practice guideline. *J Clin Endocrinol Metab* 2011;96(7):1911-30. DOI:10.1210/jc.2011-0385.
- Pearson TA, Mensah GA, Alexander RW, Anderson JL, Cannon RO 3rd, Criqui M, et al. Markers of inflammation and cardiovascular disease: application to clinical and public health practice: a statement for healthcare professionals from the Centers for Disease Control and Prevention and the American Heart Association. *Circulation* 2003;107(3):499-511. doi: 10.1161/01.cir.0000052939.59093.45.
- Todd J, Simpson P, Estis J, Torres V, Wub AH. Reference range and short- and long-term biological variation of interleukin (IL)-6, IL-17A and tissue necrosis factor-alpha using high sensitivity assays. *Cytokine* 2013;64(3):660-5. doi: 10.1016/j.cyto.2013.09.018.
- World Health Organization (WHO). The Asia-Pacific perspective: redefining obesity and its treatment. Sydney: Health Communications Australia. 2000:55p. Available at: <https://apps.who.int/iris/handle/10665/206936>.
- Sohn S, Savova GK. Mayo clinic smoking status classification system: extensions and improvements. *AMIA Annu Symp Proc* 2009;2009:619-23. Available at: <https://www.ncbi.nlm.nih.gov/pmc/articles/PMC2815365/pdf/amia-f2009-619.pdf>.
- Craig CL, Marshall AL, Sjöström M, Bauman AE, Booth ML, Ainsworth BE, et al. International physical activity questionnaire: 12-country reliability and validity. *Med Sci Sports Exerc* 2003;35(8):1381-95. doi: 10.1249/01.MSS.0000078924.61453.FB.
- Gupta AK, Brashear MM, Johnson WD. Prediabetes and prehypertension in healthy adults are associated with low vitamin D levels. *Diabetes Care* 2011;34(3):658-60. doi: 10.2337/dc10-1829.
- Shankar A, Sabanayagam C, Kalidindi S. Serum 25-hydroxyvitamin D levels and prediabetes among subjects free of diabetes. *Diabetes Care* 2011;34(5):1114-9. doi: 10.2337/dc10-1203.
- Dorcely B, Katz K, Jagannathan R, Chiang SS, Oluwadare B, Goldberg J, et al. Novel biomarkers for prediabetes, diabetes, and associated complications. *Diabetes Metab Syndr Obes* 2017;10:345-61. doi: 10.2147/DMSO.S100074.
- Zhang M, Gao Y, Tian L, Zheng L, Wang X, Liu W, et al. Association of serum 25-hydroxyvitamin D3 with adipokines and inflammatory marker in persons with prediabetes mellitus. *Clin Chim Acta* 2017;468:152-8. doi: 10.1016/j.cca.2017.02.022.
- Beifuss J, Jorde R, Kamycheva E. High-sensitivity CRP is associated with serum 25-hydroxyvitamin D levels, but is not affected by 5-Year supplementation with cholecalciferol. *J Nutr Health Food Sci* 2017;5(5):1-8. <http://dx.doi.org/10.15226/jnhfs.2017.001108>.
- Autier P, Boniol M, Pizot C, Mullie P. Vitamin D status and ill health: a systematic review. *Lancet Diabetes Endocrinol* 2014;2(1):76-89. doi: 10.1016/S2213-8587(13)70165-7.
- Cannell JJ, Grant WB, Holick MF. Vitamin D and inflammation. *Dermatoendocrinol* 2015;6(1):e983401. doi: 10.4161/19381980.2014.983401.
- Amer M, Qayyum R. Relation between serum 25-hydroxyvitamin D and C-reactive protein in asymptomatic adults (from the continuous National Health and Nutrition Examination Survey 2001 to 2006). *Am J Cardiol* 2012;109(2):226-30. doi: 10.1016/j.amjcard.2011.08.032.

COVID-19 Vaccination: Impact on Disease Severity and Mortality in an African Setting

Vacunación COVID-19: Impacto en la gravedad y mortalidad de la enfermedad en un entorno africano

Andreas Chiabi¹ , Princewill Kum Unji¹ , Alex Mambap Tatang^{1,2} , Samuel Angwafor^{1,2} , Loveline Lum Niba¹ , Minette Jaqueline Adji Porro² , Denis Nsame Nforniwe² 

1. Faculty of Health Sciences, The University of Bamenda, Cameroon

2. Bamenda Regional Hospital, Cameroon

Corresponding author

Andreas Chiabi

E-mail: andy_chiabi@yahoo.co.uk

Received: 24 - I - 2023

Accepted: 27 - II - 2023

doi: 10.3306/AJHS.2023.38.03.142

Abstract

Objectives: Ending the current COVID-19 pandemic entails attaining herd immunity, requiring high vaccination rates. However, vaccination rates remain very low in our setting, vaccine hesitancy due to lack of sufficient data on actual benefits of being vaccinated being a major cause. This study aimed at assessing the benefits of COVID-19 vaccination on disease severity and mortality.

Methods: Retrospective cohort study for COVID-19 patients managed by the Bamenda Regional Hospital from August 2021 to February 2022, using regression to assess relationship between vaccination status and disease severity, as well as mortality.

Results: The 1389 participants included in our study had a mean age of 49.5 (± 19.5) years and a female predominance 60.2% (836). A total of 81 (5.8%) patients were fully vaccinated and 77 (5.5%) were partially vaccinated. Overall, 485 (34.9%) had comorbidities, 419 (30.2%) were admitted with moderate to severe disease, among which 137 (32.7%) died. Among patients admitted with moderate to severe disease, only 2 (0.5%) were fully vaccinated and 6 (1.4%) partially vaccinated, where those fully vaccinated had lower odds of having severe disease (OR = 0.05; CI₉₅ (0.01-0.18); $p=0.000$), as well as partially vaccinated (OR = 0.15; CI₉₅ (0.06-0.35); $p=0.000$). Among patients who died, only 2 (1.5%) were partially vaccinated and none fully vaccinated, where being vaccinated (partially) did not affect odds of mortality (OR = 1.02; CI₉₅ (0.19-5.65); $p=0.980$).

Conclusion: Being fully vaccinated and to a lesser extent partially vaccinated was associated with lower odds for severe disease. As for mortality, complete vaccination was suggestive for being protective while partial vaccination had no effect.

Key words: COVID-19, mortality, severe disease, vaccination.

Resumen

Objetivos: Poner fin a la actual pandemia de COVID-19 implica lograr la inmunidad colectiva, lo que requiere altas tasas de vacunación. Sin embargo, las tasas de vacunación siguen siendo muy bajas en nuestro medio, siendo la reticencia a la vacunación por falta de datos suficientes sobre los beneficios reales de vacunarse una de las principales causas. Este estudio tuvo como objetivo evaluar los beneficios de la vacunación COVID-19 sobre la gravedad y la mortalidad de la enfermedad.

Métodos: estudio de cohorte retrospectivo para pacientes con COVID-19 atendidos por el Hospital Regional de Bamenda desde agosto de 2021 hasta febrero de 2022, utilizando regresión para evaluar la relación entre el estado de vacunación y la gravedad de la enfermedad, así como la mortalidad.

Resultados: Los 1389 participantes incluidos en nuestro estudio tenían una edad media de 49,5 ($\pm 19,5$) años y un predominio femenino del 60,2% (836). Un total de 81 (5,8%) pacientes estaban completamente vacunados y 77 (5,5%) estaban parcialmente vacunados. 485 (34,9%) tenían comorbilidades, 419 (30,2%) ingresaron con enfermedad moderada a grave, de los cuales 137 (32,7%) fallecieron. Entre los pacientes ingresados con enfermedad de moderada a grave, solo 2 (0,5%) estaban completamente vacunados y 6 (1,4%) parcialmente vacunados. Los que estaban completamente vacunados tenían menos probabilidades de tener una enfermedad grave (OR = 0,05; IC95 (0,01-0,18); $p=0,000$), así como parcialmente vacunados (OR = 0,15; IC95 (0,06-0,35); $p=0,000$). Entre los pacientes que fallecieron, solo 2 (1,5 %) estaban parcialmente vacunados y ninguno completamente vacunado, por ello estar vacunado (parcialmente) no afectó las probabilidades de mortalidad (OR = 1,02; IC95 (0,19-5,65); $p = 0,980$).

Conclusión: estar completamente vacunado y, en menor medida, parcialmente vacunado se asoció con menores probabilidades de enfermedad grave. En cuanto a la mortalidad, la vacunación completa fue sugerente por ser protectora mientras que la vacunación parcial no tuvo efecto.

Palabras clave: COVID-19, mortalidad, enfermedad grave, vacunación.

Introduction

Coronavirus disease (COVID-19) is an acute respiratory disease caused by the highly contagious novel coronavirus (SARS-CoV-2) which emerged from Wuhan, China in December 2019¹ which was declared a global pandemic in March 2020 by the World Health Organization (WHO)^{2,3}. As of the 11th November 2021, WHO weekly epidemiologic reports indicated a global rise of new COVID-19 confirmed cases and deaths with a cumulative 251 million cases for 5 million deaths since the start of the pandemic⁴. In Africa there were overall 6.2 million cases and 151 thousand deaths while Cameroon cumulatively had 105,719 cases for 1,758 deaths⁴. The several drugs currently in clinical trials for treatment, and recommended preventive measures such as social distancing and wearing of face masks have so far not been sufficient to stop the spread of the disease⁵⁻⁷.

This led to emergency development of several vaccines in order to decrease transmission and prevent progression to severe and fatal disease, and as of the 5th November 2021, WHO had approved 8 vaccines for use^{7,8}. The first mass vaccination program started in the early December 2020 and in Cameroon vaccination began in April 2021^{9,10}.

Vaccination rates as high as 67% are crucial to achieving herd immunity¹¹⁻¹³. However, vaccine trackers as of the 11th November 2021, indicated that vaccination rates were at 40.3% globally, 9.5% in Africa and only 0.6% in Cameroon¹⁴.

Despite availability of several approved vaccines, vaccine hesitancy remains a major barrier for achieving herd immunity with the major reasons being concerns related to vaccine efficacy, safety, side effects and the historic speed with which the vaccines were developed¹².

From our literature review, very little studies have been done in our context to assess the relationship between vaccination and COVID-19 related morbidity and mortality. This study will help increase our knowledge of benefits of vaccination. Hence, reduce vaccine hesitancy, thereby driving vaccination rates towards achievement of herd immunity.

Methods

This was a 7 months hospital based retrospective cohort study from the 18th August 2021 to 28th February 2022, carried out in the COVID-19 treatment centre of the Bamenda Regional Hospital. This is a second level referral hospital in the North West Region of Cameroon.

We included files of all patients aged ≥ 18 years managed by the COVID-19 treatment centre of the Bamenda Regional Hospital within the study period with RT-PCR

(polymerase chain reaction) and/or a rapid antigenic test (RDT) confirmed COVID-19, with exclusion criteria being files with incomplete data on essential elements (age, vaccination status, SpO₂, outcome). All files meeting our selection criteria were included following a consecutive non-probability sampling method. However, with expected prevalence of vaccination in Cameroon to be 15.1% from a WHO survey done in 2021¹⁵, a minimum sample size of 200 was required, with a 5% precision and 95% confidence interval. Among the recruited cases, we proceeded with extraction of data using pre-designed data collection sheets (questionnaires) which did not disclose the patient's identities. In a bid to attain our objectives and answer our research question, data on the following variables was extracted: Socio-demographic parameters (age, gender), COVID-19 vaccination status (unvaccinated, vaccinated, partially vaccinated, fully vaccinated), co-morbidities, clinical presentation, Clinical staging (asymptomatic, mild, moderate, severe/critical disease), outcome (survived, death).

We considered fully vaccinated as haven received the second dose in a 2-dose series (Sinopharm, AstraZeneca, Spoutnik, Moderna and Pfizer-BioNTech COVID-19 vaccines) or after 1 dose of the single dose Janssen (Johnson & Johnson); partially vaccinated after receipt of the first dose or <14 days after the second dose in a 2-dose series (Sinopharm, AstraZeneca, Spoutnik, Moderna and Pfizer-BioNTech COVID-19 vaccines), and unvaccinated as one who did not receive any COVID-19 vaccine dose. Regarding clinical staging, it was: asymptomatic for individuals with positive COVID-19 RDT and/or PCR in the absence of symptoms of the disease; mild for individuals who have any of the various signs and symptoms of COVID-19 (e.g. fever, cough, sore throat, malaise, headache, muscle pain, nausea, vomiting diarrhoea, loss of taste and smell) but who do not have shortness of breath, dyspnoea, or abnormal chest imaging; moderate for patients presenting with fever and signs of acute respiratory infection such as cough, difficulty in breathing, respiratory rate 20-29 bpm, heart rate > 90 but < 120 bpm, SPO₂ > 92% with or without manifestations of pneumonia can be seen on imaging; and severe illness considered for presentation with fever (temperature > 38.5°C), signs of acute infection and at least one of the following criteria: Respiratory rate > 30 bpm, severe respiratory distress, SpO₂ < 92% in ambient air, progression of pulmonary lesions in imaging > 50% in 24-48h, cyanosis, impaired consciousness¹⁶. Admission criteria being patients with moderate to severe disease¹⁶.

Ethical considerations

Ethical clearance was obtained from the Institutional Review Board (IRB) of the Faculty of Health Sciences of the University of Bamenda (No: 2022/0395H/UBa/IRB) and administrative authorization to carry out the research in the North West Region was obtained from the North West Regional Delegation of Public Health.

An administrative authorization to carry out the research in the COVID-19 treatment center of the BRH was also obtained from the Director of the hospital.

Data management and analysis

Data was collected using a password protected REDCap (Research Electronic Data Capture) account designed to capture data for clinical research and create a data base which was exported to Microsoft office excel 2016. Analysis was done using the statistical software SPSS (Statistical Package for the Social sciences) version 26, with statistical significance defined by a p-value <0.05 using logistic regression analysis to assess cause to effect between predictor and outcome variables. Continuous variables were expressed as mean \pm standard deviation (SD), while categorical variables were expressed as proportions or percentages.

Results

From 18th August 2021 to 28th February 2022, 1917 records of patients managed by the COVID-19 treatment centre during our study period were retrieved. Two hundred and eighteen (218) were aged < 18 years and three hundred and ten (310) had incomplete data on our important variables. The remaining one thousand three hundred and eighty-nine (1389) were included in our study.

Out of 1389 patients, majority 836 (60.2%) were females, giving a male to female sex ratio of 0.7. The age ranged from 18 to 100 years, with a mean of 49.52 (\pm 19.48) years; 34.9% (485) had comorbidities; majority 40.4% (561) had the mild form of the disease (**Table I**). Of the 485 patients with comorbidities, the most common were Hypertension 351 (72.4%), Diabetes mellitus 145 (29.9%) and HIV 46 (9.5%) (**Figure 1**).

A total of 157 were vaccinated giving a vaccination rate of 11.3%. Four hundred and twenty-three (30.5%) were admitted while 966 (69.5%) were managed on home confinement. Of the 423 admissions, 8 were vaccinated giving a vaccination rate of 1.9% among

hospitalised. Also, 81 (5.8%) were fully vaccinated and 76 (5.5%) partially vaccinated (**Figure 2**). Among those fully vaccinated, majority were females 47 (58.0%), aged \leq 60 years 68 (84.0%), had no comorbidities 60 (74.1%), and had mild disease 52 (64.2%) (**Table II**). Regarding the vaccines, 139 vaccine doses were received by our participants, majority of which were the Johnson and Johnson vaccine 62 (44.6%).

Among the 419 patients with moderate to severe form of the disease, majority, 411 (98.1%) were not vaccinated, 221 (57.7%) were females, 303 (72.3%) were aged > 60 years, and 255 (60.9%) had comorbidities. Being fully vaccinated (aOR=0.015; $CI_{95}(0.00-0.09)$; $p=0.000$) and partially vaccinated (aOR=0.129; $CI_{95}(0.04-0.419)$; $p=0.001$) were protective factors whereas, being a male (aOR=2.15; $CI_{95}(1.46-3.18)$; $p=0.000$); being aged > 60 (aOR=24.74; $CI_{95}(16.38-37.35)$; $p=0.000$) and having comorbidities (aOR=12.43; $CI_{95}(8.14-18.99)$; $p=0.000$) increased the risk (**Table III**).

Among the 137 patients who died, majority, 135 (98.5%) were not vaccinated, 78 (56.9%) were males; 121 (88.3%) aged > 60 years and 87 (63.5%) had comorbidities. After adjusting for confounders, the odds of dying were increased by being of male gender (aOR=1.83; $CI_{95}(1.19-2.81)$; $p=0.006$) and being aged > 60 years (aOR=4.30; $CI_{95}(2.41-7.68)$; $p=0.000$). Vaccination status had no significant effect on mortality (**Table IV**).

Discussion

This study was aimed at determining the vaccination rate, assess the relationship between vaccination status and disease severity as well as mortality in patient managed by the COVID-19 treatment centre of BRH. The results were analysed in accordance with our objectives making it possible to meet the said objectives.

However, there are limitations to this study. It was a retrospective study and some missing data was noted in some files. Some of the severe cases and/or deaths might have been directly related to comorbidities rather than COVID-19. Vaccination was done only in adults above 18 years, so we could not assess severity and mortality in all age groups. That notwithstanding, despite these limitations, we attained our prior set objectives.

The vaccination rate of 11.3% we found was similar to a WHO survey done in 2021 in the south west region of Cameroon which had 15.1% vaccination rate¹⁵, but was far lower from the 43% findings of Muthukrishnan et al in India, 2021. That was half that of Naleway et al, 2021 US who found a vaccination rate of 22.3%¹⁷. This difference could be due to the fact that Cameroon has higher vaccination hesitancy rates compared to high-income countries and unavailability of all vaccines all the time¹⁸.

Table I: Characteristics of the study population (N =1389).

Variables	Number	Percentage (%)
Sex		
Male	553	39.8
Female	836	60.2
Age (years)		
\leq 60	931	67.0
> 60	458	33.0
Comorbidities		
Present	485	34.9
Absent	904	65.1
Classification		
Asymptomatic	62	4.4
Mild	561	40.4
Moderate	451	32.5
Severe	315	22.7

Table II: Characteristics of the study population according to vaccination status (N =1389).

Variables	Fully Vaccinated* N = (81)		Not Vaccinated** N = (1308)		TOTAL N = (1389)	
	Number	%	Number	%	Number	%
Sex						
Male	34	42.0	519	39.7	553	39.8
Female	47	58.0	789	60.3	836	60.2
Age (years)						
≤ 60	68	84.0	863	66.0	931	67.0
> 60	13	16.0	445	34.0	458	33.0
Comorbidities						
Present	21	25.9	464	35.5	485	34.9
Absent	60	74.1	844	64.5	904	65.1
Classification						
Asymptomatic	4	4.9	58	4.4	62	4.4
Mild	52	64.2	509	38.9	561	40.4
Moderate	23	28.4	428	32.7	451	32.5
Severe	2	2.5	313	23.9	315	22.7

* Any patient who has received one dose of Johnson and Johnson or 2 doses of Sinopharm or Astrazeneca

**Any patient who hasn't received any dose of vaccine or just one dose of Sinopharm or Astrazeneca.

Table III: Vaccination status and other factors related to disease severity (N =1038).

Variables	Group 1*	Group 2**	Multivariate logistic regression			
	Number (%)	Number (%)	OR [95% CI]	P-value	aOR [95% CI]	P-value
Vaccination status						
Not vaccinated	411 (98.1)	513 (82.9)	Reference		Reference	
Fully vaccinated	2 (0.5)	56 (9.0)	0.05 [0.01-0.18]	0.000	0.015 [0.002-0.087]	0.000
Partially vaccinated	6 (1.4)	50 (8.1)	0.15 [0.06-0.35]	0.000	0.129 [0.040-0.419]	0.001
Gender						
Female	221 (57.7)	386 (62.4)	Reference		Reference	
Male	198 (42.3)	233 (37.6)	1.48 [1.15-1.91]	0.002	2.15 [1.46-3.18]	0.000
Age (years)						
≤ 60	116 (27.7)	560 (90.5)	Reference		Reference	
> 60	303 (72.3)	59 (9.5)	24.79 [17.59-34.94]	0.000	24.74 [16.38-37.35]	0.000
Comorbidities						
Absent	164 (39.1)	545 (88.0)	Reference		Reference	
Present	255 (60.9)	74 (12.0)	11.45 [8.38-15.65]	0.000	12.43 [8.14-18.99]	0.000

Group 1*: patients with asymptomatic to mild form (not hospitalised)

Group 2**: patients with moderate to severe form (hospitalised)

Table IV: Vaccination status and other factors related to mortality in admitted patients (N= 419).

Variables	Died	Survived	Multivariate logistic regression			
	Number (%)	Number (%)	OR [95% CI]	P-value	aOR [95% CI]	P-value
Vaccination status						
Not vaccinated	135 (98.5)	276 (97.9)	Reference		Reference	
Fully vaccinated	0 (0.0)	2 (0.7)	Undefined		Undefined	
Partially vaccinated	2 (1.5)	4 (1.4)	1.02 [0.19-5.65]	0.980	1.31 [0.21-8.12]	0.765
Gender						
Female	57 (43.1)	162 (54.4)	Reference		Reference	
Male	78 (56.9)	120 (42.6)	1.79 [1.18-2.70]	0.006	1.83 [1.19-2.81]	0.006
Age (years)						
≤ 60	16 (11.7)	100 (35.5)	Reference		Reference	
> 60	121 (88.3)	182 (64.5)	4.16 [2.34-7.39]	0.000	4.30 [2.41-7.68]	0.000
Comorbidities						
Absent	50 (36.5)	114 (40.4)	Reference		Reference	
Present	87 (63.5)	168 (59.6)	1.18 [0.78-1.80]	0.440	1.27 [0.82-1.97]	0.287

Being fully and partially vaccinated were found to be protective factors against severe forms of the disease, with fully being more protective than partially. This was similar to results of a study by Mohammed et al, in 2022 which showed that vaccination effectively reduces the chances of getting severe disease¹⁹, as well as with findings of Macchia et al in Argentina, 2021 which

found that being fully as well as partially vaccinated was associated with lesser risk of getting severe disease²⁰.

On the other hand, other factors were found to increase the risk of severity. These included Being of male gender; which could be explained by the fact that androgen play an important role in COVID-19 infectivity. Following

binding to ACE 2 receptors, SARS-CoV-2 requires Type II transmembrane Serine Protease (TMPRSS2) to enable fusion and entry into the host cell. This receptor has been found to be up regulated by androgens, so with males having higher levels of androgens compared to females; this could explain more severe disease in males²¹. Being aged > 60 years; which could be explained by the increased expression of ACE2 receptors in older patients. This receptor has been established as the functional host receptor for SARS-CoV-2. As a recall, vaccines against COVID-19 all lead to the production and exposure of the immune system to viral-like antigens which stimulate both cellular (through T cells) and Humoral (through B cells which produce antibodies) to keep a memory of the offending agent thereby mounting a strong and fast response when confronted to the infection. This response diminishes with aging (immunoscience), which can explain increased severity in older patients as a result of inadequate vaccine-induced protection²².

And having comorbidities; which could be explained by the fact that majority of patients with comorbidities had hypertension and diabetes mellitus among others which are associated with increased expression of ACE2 receptors²³. Moreover, it could equally be explained by the fact that comorbidities are associated to the process of immunoscience mentioned earlier making such patients more susceptible to severe disease.

The effect of being fully vaccinated on mortality couldn't be assessed as no fully vaccinated died, whereas, being partially vaccinated had no significant effect on mortality. This was consistent with to the findings of Muthukrishnan et al in India, 2021 where being partially vaccinated equally had no significant effect on mortality²⁴, but was different from findings of Macchia et al in Argentina 2021 who found that being fully as well as partially vaccinated was associated with lesser chances of mortality²⁰. These differences can be explained by the effects of various variants in certain populations conferring certain degrees of resistance to vaccine-induced protection⁵. Moreover, there is the implementation of vaccine boosters in some countries which could influence the degree of protection conferred by vaccination. Furthermore, administration of different vaccine types could be related to different degrees of vaccine-induced immunisations.

That notwithstanding, certain factors were found to increase the odds of mortality. They include: Being of male gender which was consistent with findings of Hippisley-cox et al in 2021 in the United Kingdom which showed increased mortality among males²⁵, but contrary to the findings of Muthukrishnan et al in India, 2021 where it was rather being a female which was associated with mortality²⁴. This difference could be due to different gender and racial characteristics of different populations.

In addition, being aged > 60 years equally increased the odds of dying. which was similar to the findings of

Muthukrishnan et al in India, 2021 where increasing age was associated with an increased odds of mortality²⁴. This is consistent with the fact that older patients are prone to poorer outcomes in infectious diseases due to higher expressions of ACE2 receptors and also dysfunction of immune response (immunoscience) after vaccine administration or prior infection^{22,26}.

The vaccination rate in the COVID-19 treatment centre of the BRH was 11.3%, with 5.8% actually being fully vaccinated for 5.5% partially, with Johnson & Johnson being the most frequently received vaccine (44.6%). Vaccination against COVID-19 was associated with decreased odds of having severe disease, which was more in fully vaccinated compared to partially vaccinated. Being of female gender, aged ≤ 60 years and absence of comorbidities decreased the odds of severe disease. The effect of complete vaccination on mortality could not be assessed due absence of any deaths among admitted patients who were fully vaccinated, whereas partial vaccination had no significant effect on mortality. However, the absence of any fully vaccinated among deaths is suggestive of protective effect of complete vaccination. Moreover, being a female and aged ≤ 60 years decreased odds of dying.

Acknowledgments

We are grateful to the staff of the COVID-19 treatment centre of the Bamenda Regional Hospital for their technical assistance throughout the data collection phase.

Authors' Contributions

1. Conception – A.C, P.K.U; 2. Design – A.C; 3. Supervision A.C, A.M.T, S.A; 4. Resources- D.N.N, S.A; 5. Materials -D.N.N; 6. Data Collection and/or Processing - P.K.U, A.M.T, A.M.J.P; 7. Analysis and/or Interpretation – P.K.U, A.M.T; 8. Literature Review - P.K.U, A.C, A.M.T; 9. Writing – P.K.U, A.C; 10. Critical Review –A.C., A.M.T, L.L.N, A.M.J.P.

Ethical statement

Ethical clearance was obtained from the Institutional Review Board (IRB) of the Faculty of Health Sciences of the University of Bamenda (No: 2022/0395H/UBa/IRB) an administrative authorization to carry out the research in the North West Region was obtained from the North West Regional Delegation of Public Health. An administrative authorization to carry out the research in the COVID-19 treatment center of the BRH was also obtained from the Director of the hospital.

Conflict of Interest Disclosures

The authors declare that they have no known competing financial interests or personal relationships that could have influenced the work reported in this paper.

Funding

The authors declare that this study has received no financial support.

References

1. Olum R, Chekwech G, Wekha G, Nassozi DR, Bongomin F. Coronavirus Disease-2019: Knowledge, Attitude, and Practices of Health Care Workers at Makerere University Teaching Hospitals, Uganda. *Front Public Health*. 2020;8:181. doi: 10.3389/fpubh.2020.00181
2. Alyami MH, Naser AY, Orabi MAA, Alwafi H and Alyami HS. Epidemiology of COVID-19 in the Kingdom of Saudi Arabia: An Ecological Study. *Front Public Health*. 2020;8:506. doi: 10.3389/fpubh.2020.00506
3. Sabnis R, Patil A, Shete N, Rastogi AK. Break-through COVID-19 infection rate with Indian strain in Single-center Healthcare Workers. [cited 2021 Nov 4] Available from <https://www.medrxiv.org/content/10.1101/2021.07.02.21258881v1>.
4. WHO Coronavirus (COVID-19) Dashboard. [cited 2021 Nov 13]. Available from: <https://covid19.who.int>
5. COVID-19 Treatment Guidelines Panel. Coronavirus Disease 2019 (COVID-19) Treatment Guidelines. National Institutes of Health. Available at <https://www.covid19treatmentguidelines.nih.gov/>. Accessed [2021 Nov 7].
6. Advice for the public on COVID-19 – World Health Organization. [cited 2021 Nov 11]. Available from: <https://www.who.int/emergencies/diseases/novel-coronavirus-2019/advice-for-public>
7. Jara A, Undurraga EA, González C, Paredes F, Fontecilla T, Jara G, et al. Effectiveness of an Inactivated SARS-CoV-2 Vaccine in Chile. *N Engl J Med*. 2021;385:875–84. doi: 10.1056/nejmoa2107715
8. WHO – COVID19 Vaccine Tracker. [cited 2022 Nov 11]. Available from: <https://covid19.trackvaccines.org/agency/who/>
9. Coronavirus disease (COVID-19): Vaccines. [cited 2022 Nov 7]. Available from: [https://www.who.int/news-room/q-a-detail/coronavirus-disease-\(covid-19\)-vaccines](https://www.who.int/news-room/q-a-detail/coronavirus-disease-(covid-19)-vaccines)
10. MINSANTE| Covid-19: La vaccination a commencé. [cité le 7 Nov 2021]. Disponible sur: <https://www.minsante.cm>.
11. Outbreaks and Emergencies Bulletin, Week 43: 18 - 24 October 2021. WHO | Regional Office for Africa. [cited 2022 Nov 6]. Available from: <https://www.afro.who.int/publications/outbreaks-and-emergencies-bulletin-week-43-18-24-october-2021>
12. Cascini F, Pantovic A, Al-Ajlouni Y, Failla G, Ricciardi W. Attitudes, acceptance and hesitancy among the general population worldwide to receive the COVID-19 vaccines and their contributing factors. *EClinicalMedicine*. 2021;40:101113. doi: 10.1016/j.eclim.2021.101113
13. Randolph HE, Barreiro LB. Herd Immunity: Understanding COVID-19. *Immunity*. 2020;52:737–41. doi: 10.1016/j.immuni.2020.04.012
14. Ritchie H, Mathieu E, Rodés-Guirao L, Appel C, Giattino C, Ortiz-Ospina E, et al. Coronavirus Pandemic (COVID-19). *Our World in Data*. 2020 [cited 2021 Nov 13]; Available from: <https://ourworldindata.org/covid-vaccinations>
15. Cameroon: North-West and South-West Health Cluster COVID-19 Epidemiological Bulletin (July, 2021) - Cameroon. ReliefWeb. [cited 2022 Nov 29]. Available from: <https://reliefweb.int/report/cameroon/cameroon-north-west-and-south-west-health-cluster-covid-19-epidemiological-bulletin>
16. Ministry of Public Health Emergency Operations Centre (PHEOC). Management protocol of COVID-19 cases in Cameroon, June 2021 Edition.
17. Naleway AL, Groom HC, Crawford PM, Salas SB, Henninger ML, Donald JL, et al. Incidence of SARS-CoV-2 Infection, Emergency Department Visits, and Hospitalizations Because of COVID-19 Among Persons Aged ≥12 Years, by COVID-19 Vaccination Status — Oregon and Washington, July 4–September 25, 2021. *MMWR Morb Mortal Wkly Rep*. 2021;70:1608–12. doi: 10.15585/mmwr.mm7046a4
18. Ngwewondo A, Nkengazong L, Ambe LA, Ebogo JT, Mba FM, Goni HO, et al. Knowledge, attitudes, practices of/towards COVID 19 preventive measures and symptoms. *PLoS Negl Trop Dis*. 2020;14:e0008700. doi: 10.1371/journal.pntd.0008700
19. Mohammed I, Nauman A, Paul P, Ganesan S, Chen K-H, Jalil SMS, et al. The efficacy and effectiveness of the COVID-19 vaccines in reducing infection, severity, hospitalization, and mortality: a systematic review. *Hum Vaccines Immunother*. 2022;18:2027160. doi: 10.1080/21645515.2022.2027160
20. Macchia A, Ferrante D, Angeleri P, Biscayart C, Mariani J, Esteban S, et al. Evaluation of a COVID-19 Vaccine Campaign and SARS-CoV-2 Infection and Mortality Among Adults Aged 60 Years And Older in a Middle-Income Country. *JAMA Netw Open*. 2021;4(10):e2130800. doi:10.1001/jamanetworkopen.2021.30800
21. Mjaess G, Karam A, Aoun F, Albisinni S, Roumeguère T. COVID-19 and the male susceptibility: the role of ACE2, TMPRSS2 and the androgen receptor. *Prog En Urol*. 2020;30(10):484-7. doi: 10.1016/j.purol.2020.05.007
22. Chen Y, Klein SL, Garibaldi BT, Li H, Wu C, Osevala NM, et al. Aging in COVID-19: Vulnerability, immunity and intervention. *Ageing Res Rev*. 2021;65:101205. doi:10.1016/j.arr.2020.101205
23. Bourgonje AR, Abdulle AE, Timens W, Hillebrands J-L, Navis GJ, Gordijn SJ, et al. Angiotensin-converting enzyme-2 (ACE2), SARS-CoV-2 and pathophysiology of coronavirus disease 2019 (COVID-19). *J Pathol*. 2020;251(3):228–48. doi: 10.1002/path.5471
24. Muthukrishnan J, Vardhan V, Mangalesh S, Koley M, Shankar S, Yadav AK, et al. Vaccination status and COVID-19 related mortality. *Med J Armed Forces India*. 2021;77:S278–82. doi: 10.1016/j.mjafi.2021.06.034
25. Hippisley-Cox J, Coupland CA, Mehta N, Keogh RH, Diaz-Ordaz K, Khunti K, et al. Risk prediction of covid-19 related death and hospital admission in adults after covid-19 vaccination: national prospective cohort study. *BMJ*. 2021;374:n224. doi: 10.1136/bmj.n2244
26. Soiza RL, Scicluna C, Thomson EC. Efficacy and safety of COVID-19 vaccines in older people. *Age Ageing*. 2021;50:279–83. doi: 10.1093/ageing/afaa274

La guerra de Apolo contra las fiebres: Rafel Rapó, Mallorca (1707)

Apollo's war against fevers: Rafael Rapó, Majorca (1707)

Antoni Contreras Màs

*Psiquiatra. Académico Correspondiente
Investigador del Grup d'Investigació d'Història de la Salut-IUNICS*

Corresponding author

Antoni Contreras Màs
E-mail: a.comas12@gmail.com

Received: 26 - I - 2023

Accepted: 29 - II - 2023

doi: 10.3306/AJHS.2023.38.03.148

Resumen

El médico mallorquín Rafael Rapó i Font, natural de Sineu, fue miembro de una familia de intelectuales de su localidad natal. Ejerció como médico militar, sirviendo en la Armada Real. Tras retirarse del servicio, se instaló en la capital de Mallorca, donde continuó ejerciendo su profesión. Es autor de un estudio sobre las fiebres y su tratamiento titulado *Apollineum Majoricense bellum contra febres perniciosas*, redactado seguramente a comienzos del setecientos e impreso en 1707 en Ciutat de Mallorca. Sus páginas abordan el entonces preocupante tema de las fiebres, de las cuales realiza un estudio siguiendo la perspectiva galénica, propia de la época. Su publicación vino a sumarse a una literatura piretológica entonces muy activa, como reflejan las numerosas obras sobre esta cuestión la precedieron, las cuales reflejan asimismo la relevante atención dispensaba a esta cuestión por los médicos de la época. Fue también autor de una obra literaria dedicada al elogio de la Casa Real de Austria y al matrimonio entre Carlos II y María Luisa de Borbón.

Palabras clave: Rafel Rapó, Mallorca, Sineu, siglos XVII y XVIII, historia de la medicina, galenismo moderado, fiebres, piretología.

Abstract

The Majorcan physician Rafael Rapó i Font, born in the town of Sineu, was a member of a family of intellectuals from his place of birth. He practised as a military physician in the Royal Navy. After leaving the Navy, he settled in the capital of Majorca, Palma, where he continued with his profession. He is the author of a study about fevers and their treatment with the name *Apollineum Majoricense bellum contra febres perniciosas*, written certainly at the beginning of the 18th century, which was printed in 1707 in Ciutat de Majorca [Palma]. Its pages tackle the then worrying question of fevers, about which he wrote a study following the Galenical prospect, typical of that time. Its publication came to be added to pyretological literature very active then, as reflect the large amount of works about fevers that preceded Rapó's, also proving the relevant interest of physicians of that time dedicated to that issue. Rapó was also the autor of a literary work dedicated to praising the Royal Dynasty of the Hasburgs, and the marriage between the King of Spain, Charles II, and María Luisa of Bourbon.

Key words: Rafel Rapó, Majorca, Sineu, 17th and 18th centuries, history of medicine, moderate galenism, fevers, pyretology.

Introducción

En la primera década del siglo XVIII, tras un período de veinte años sin publicaciones de literatura médica en Mallorca, el médico Rafel Rapó i Font dio a la imprenta un extenso tratado dedicado a las fiebres. Lo tituló *Apollineum Majoricense bellum contra febres perniciosas*¹, acogiéndose al dios Apolo, reconocido patrón clásico de la Medicina², como protector en su lucha contra uno de los problemas más preocupantes y frecuentes del quehacer médico diario de la época. La obra ofrecida por nuestro autor venía a sumarse al extenso listado con el cual la comunidad médica de aquella época trató de dar respuesta a la elevada e importante incidencia alcanzada por tal patología.

Los procesos febriles y calenturas o fiebres eran la patología más reiterada y a menudo grave de la época, ocupando un lugar preferente y con frecuencia el principal en la práctica cotidiana de los médicos. Su destacada incidencia concitó la atención de éstos profesionales, dando lugar a un importante núcleo de literatura médica, iniciado en el siglo XVI y con un especial relieve en la segunda mitad del XVII y todo el XVIII.

El texto y biografía de Rapó han quedado excluidos de esos escritos en tratados generales de historia de la medicina española moderna como el de Pedro Lain Entralgo (1963)³ o los específicos del seiscientos y setecientos de Sánchez Granjel (1979)⁴. En cambio sí aparece mencionado por Bover Rosselló en sus bibliografías mallorquinas de (1842) y (1868)⁵ y en el *Diccionari* de médicos catalanes de Josep M^a Calbet i Camarasa y Jacint Corbella i Corbella (1982)⁶. José M^a López Piñero le dedica un breve comentario en *Medicina e Historia Natural en la sociedad española de los siglos XVI y XVII* (2007). Valora su contenido como un tratado general de las fiebres, con estudios específicos de las fiebres *pútridas*, *perniciosas* e *intermitentes* y un apéndice dedicado a la *hectica*, propia de lo que hoy llamamos *tuberculosis pulmonar*⁷. Un comentario posterior, lo consideró como una *adocenada muestra de la "medicina racional y dogmática" desde la que numerosos médicos se opusieron a las innovaciones doctrinales en encendidas controversias durante la década de su publicación*⁸.

La fiebre, las fiebres y las calenturas

El diagnóstico de fiebre venía realizándose desde tiempos hipocráticos, identificándola a través de la sensación subjetiva del calor al tacto. Se la consideraba un signo manifiesto de enfermedad y daba lugar a una aventurada interpretación como indicador de pronóstico, según las diferentes pautas y características presentadas por su periodicidad o intensidad térmica. En el modelo fisiológico humoral hipocrático era entendida como una respuesta del cuerpo para eliminar la causa de enfermedad y recobrar el equilibrio humoral identificado con la salud.

Dicho modelo de entender la salud y la enfermedad quedó recogido en el grupo de escritos conocido como *Corpus Hippocraticum*, que constituyen uno de los principales núcleos de textos que fundamentaron la base empírica de toda la tradición médica occidental. Para algunos, la llamada «Escuela Hipocrática» llegó a discernir la evolución y el pronóstico de los cuadros febriles. Les adjudicó el nombre de «fiebres» a los que tenían tendencia espontánea a mejorar, como la

fiebre tifoidea, la fiebre reumática o las fiebres palúdicas. En cambio, denominó «pirexia» a las entidades febriles con agravación progresiva hacia la muerte. En esos escritos podemos encontrar descripciones precisas de enfermedades febriles, introduciendo las distinciones de fiebres cotidianas, tercianas y cuartanas.

Los tratados hipocráticos de *Epidemias* 5 y 7, datados alrededor del 400 a. C., consideran la fiebre conceptuándola consecuencia de la alteración causada por la enfermedad en el cuerpo. Su causa principal y más frecuente es el humor conocido como bilis. Sus variaciones dependen del conjunto de factores personales del paciente y de la temporada, aunque ciertos alimentos eran considerados predisponentes al exceso de bilis y por lo tanto a la fiebre. Influyó también la temperatura ambiente, lo cual permitía explicar y justificar su presencia más frecuente en verano, estación en la cual se entendía que se producía habitualmente un aumento de la bilis dentro del cuerpo. Esas peligrosas y asiduas fiebres veraniegas debían tratarse con una dieta apropiada, o en su caso una lactancia, ambas especialmente cuidadosas, para evitar que acabasen



convirtiéndose en enfermedades del peor pronóstico.

Tanto el autor como el compilador de *Epidemias* 5 y 7 no muestran excesivo interés en proporcionar explicaciones para el mecanismo de producción de la fiebre. Las proporcionará principalmente Galeno de Pérgamo (129 d. C.-c. 200) que enmarca sus experiencias clínicas dentro de su teoría general de la patología. Escritos específicos de este autor encaminados a explicarla serán *Sobre las formas [de fiebre] (De typis)* o *De Methodo Medendi ad Glauconem (Del método terapéutico a Glaucón)*⁹. Sus exposiciones recibieron severas críticas por algunos de sus coetáneos, a los que respondió con el texto titulado: *Contra los que escribieron sobre las formas y los períodos [de las fiebres] (Adversus eos, qui de typis scripserunt)*¹⁰.

Aunque desde la antigüedad la fiebre fue una de las entidades patológicas más importantes, es difícil encontrar una teoría coherente para explicarla hasta Galeno. Este muy prestigioso autor fue quien integró las diversas teorías de sus predecesores, concibiendo la teoría de la fiebre más completa y mejor articulada de la antigüedad. La fiebre fue entendida por este médico como una discrasia general y caracterizada por un aumento de calor corporal. La variación de este calor corporal le servirá como instrumento de diferenciación entre los varios tipos de fiebre, cuestión a la que dedicará el *Sobre las diferencias de las fiebres (De differentiis februm)*, una de sus obras más representativas sobre este problema. En este tratado se aborda la etiología y diagnóstico de las diferentes fiebres, atendiendo en especial el problema de distinguirlas y clasificarlas. Dado que la fiebre es un fenómeno patológico bastante general y común, no era fácil diferenciarlas. Galeno trató de proponer criterios y proporcionar una base sustancial para ello, proponiendo la clasificación de fiebres más coherente y exhaustiva conocida hasta entonces. Fundamentó su clasificación de las fiebres en su esencia, dividiéndolas en tres tipos principales: fiebre efímera¹¹, fiebre héctica¹² y fiebre pútrida¹³. Las relacionó respectivamente con las tres estructuras materiales existentes en el organismo humano: la efímera con el elemento aéreo, la pútrida con los líquidos y la héctica con los sólidos.

Ya los tratados de Galeno consideran que la fiebre podía, a su vez, ser un mero síntoma o una enfermedad en sí misma, clasificándola como una discrasia caliente, generalizada y con materia. En la actualidad la fiebre se considera tan solo un signo más de enfermedad, pero tradicionalmente fue entendida durante mucho tiempo, siguiendo el criterio galénico, como una enfermedad en sí misma. En ese sentido podemos hallarla bajo numerosas identificaciones diferentes, tales como efímera, héctica, intermitente¹⁴, etc., en función de sus características clínicas y evolución temporal.

Las fiebres efímeras las consideraba debidas a una causa productora de calor, múltiple y atribuible a cualquier

discrasia caliente, exceptuando el incremento de calor debido a la putrefacción de los humores. Era debida a un exceso de trabajo reflejado en una hipertermia causada por el exceso de frotamiento de músculos, nervios o articulaciones. Las fiebres pútridas tenían su origen en la putrefacción de uno o más de los cuatro humores hipocráticos. Iban asociadas a un amplio y variado cortejo sintomatológico, en cuya descripción Galeno observa la opinión de los humoralistas hipocráticos de manera precisa. En este caso la naturaleza de la fiebre dependía del humor que entraba en putrefacción, tras el fracaso de la fuerza curativa de la naturaleza (*vix curatrix naturae*). El tercer tipo de fiebres identificadas por Galeno son las hécticas, a las cuales consideraba, más que a las otras dos, como una enfermedad en sí misma. Las estimaba ocasionadas por una alteración en la propia sustancia del corazón o la consecuencia evolutiva de otras fiebres al cronificarse. Las concebía como una afección caliente radicada en las partes sólidas del organismo, ocasionada por los otros tipos de fiebre que habían seguido, en la mayoría de los casos, un desarrollo nocivo o crónico.

Las interpretaciones de la medicina árabe observaron rigurosamente los planteamientos de Galeno. Así podemos verlo reflejado en el libro IV del magistral *Canon (Kitab al Qanun)* de Avicena (980-1037) de proyección decisiva en Occidente durante toda la Edad Media y buena parte del período renacentista. Su notable difusión y aceptación en los círculos médicos bajomedievales fueron las bases de la importante corriente intelectual conocida como «galenismo arabizado», en la cual se movieron de forma parcial o total, buena parte de los médicos de esas centurias. Su destacado prestigio lo sitúa prácticamente al mismo nivel que los grandes maestros como Hipócrates y Galeno, de los cuales es un indudable y manifiesto seguidor.

Su ideología se mantendrá en esa línea de continuidad a la hora de ocuparse de las enfermedades sistémicas, no específicas de un órgano concreto, entre las cuales destaca especialmente el tema de las fiebres. En este contexto aborda el problema de los procesos febriles, su clasificación, géneros y sintomatología, pronóstico, episodios de crisis y los llamados «días críticos». A estos últimos les dedicó su escrito de ese título, el cual como otras muchas versiones de los textos galénicos, fue introducido en los saberes médicos del mundo medieval a través de versiones reducidas. Dichos «resúmenes», en algunos casos, además de reducir el texto galénico original, incorporaron revisiones de las enseñanzas galénicas. Su exposición presenta las fiebres como una forma patológica que encamina al sujeto a una crisis determinante para su destino. El final del ciclo de la enfermedad podía conocerse a través de una atenta observación, aunque para buscar su causa, Galeno y sus intérpretes posteriores optaron por recurrir a métodos astrológicos o numerológicos¹⁵.

Asimismo describe todo lo referente a sus diferentes diagnósticos diferenciales y recursos terapéuticos específicos para cada una de las formas explicadas¹⁶. Una devoción similar por las doctrinas de Galeno, podemos advertirla también en la concepción que el destacado comentarista árabe andalusí Ibn Rusd (1126-1198) el Averroes latino, mantuvo sobre la fiebre. La explicación averroísta entiende ese padecimiento como una unidad, compuesta por el calor natural y el preternatural. Su propuesta pondrá los fundamentos del prologado debate planteado en la medicina posterior acerca del origen y características del síndrome febril.

Ésa teoría tuvo que enfrentarse a una importante dificultad. Según la fisiología galénica, todo organismo viviente, para serlo, poseía un grado y cantidad determinados de calor interior. Este calor natural e innato podía sufrir variaciones ocasionales y esporádicas. No eran consideradas patológicas ya que se contemplaban como parte del desarrollo normal del funcionalismo orgánico. Su influencia en la teoría de las fiebres se mantendrá, con algunas imprescindibles y evidentes modificaciones, prácticamente hasta la segunda mitad del siglo XIX¹⁷.

Dicha teoría galénica sobre la fiebre fue aceptada de modo progresivo como la base más válida para la práctica médica en el Mediterráneo Oriental y en Occidente desde el siglo XII. El manual piretológico básico de los médicos medievales lo constituyeron los cinco libros sobre las fiebres del *Kitab al-Hummayat* redactados por Ishaq ben Suleiman al-Israili (m. 923) el Isaac Israelí o Isaac Judaeus latino. Tanto árabes como latinos y judíos, contaron con traducciones en sus lenguas respectivas a la hora de enfrentarse a esa forma de enfermar, a la vez síntoma y entidad patológica para el galenismo. Su traducción latina por el monje Constantino en Montecassino, permitió su traducción al castellano y al catalán¹⁸. La perspectiva que proporciona sobre las fiebres, inspirada directamente en las ideas de Galeno, mantendrá su predominio vigente hasta que en el siglo XVII la nosografía sydenhamiana comience a ordenar con nuevos criterios la clasificación de las fiebres.

Durante esa época los tratados dedicados a las fiebres iban poco más allá de las sinopsis de Galeno, pero entender las explicaciones proporcionadas por la obra galénica no resultaba cosa fácil. A ello se añadían las dificultades que entrañaban las distintas interpretaciones de sus manuscritos conservados y recuperados, dispersas entre sus muchas obras y casi sesenta años de escritura. Esto propició que su comprensión condujese inevitablemente a confusiones, fruto habitual de sus interpretaciones entre quienes posteriormente las conocieron y adoptaron como principal método explicativo de la enfermedad y la salud. Este problema de las fiebres fue uno de los que más cuestionaron la concepción galénica de la medicina. La diferenciación entre el calor de la fiebre y el llamado "calor innato"

desencadenó una de las polémicas más conflictivas para el galenismo tradicional.

Los médicos del siglo XVI trataron de conciliar esas cuestiones y unificar los distintos puntos de vista de los saberes médicos, fisiológicos, nosológicos y terapéuticos. Todos ellos permanecieron en su mayoría fundamentándose de modo esencial en el reconocimiento de la absoluta autoridad de las obras de Galeno. Los innovadores aires del renacimiento propiciaron algunas rebeliones notables contra esas doctrinas. Las principales discrepancias las plantearon Aureolo Felipe Teofrasto Bombast von Hohenheim (1493-1541) conocido como Paracelso y Girolamo Cardano (1501-1576) que mostraron su disconformidad absoluta con el galenismo. En la segunda mitad del siglo los seguidores de las ideas sobre la medicina preconizadas por Paracelso mantuvieron un enfrentamiento constante con las opiniones de los galenistas, tanto si eran seguidores de las corrientes arabizadas o las hipocratistas. Tales debates sobre la fiebre precedieron muchos de los enfoques conflictivos posteriores, generando importantes contribuciones para su comprensión y conciliación. Serían expuestas por un amplio número de autores que de muchas maneras se mostraban reticentes a su explicación tradicional¹⁹.

Antecedentes bibliográficos españoles

Una de las discusiones más destacadas en el campo de la piretología, produjo una revisión relativamente amplia y agresiva del saber médico galénico tradicional. Su principal protagonista fue Antonio Gómez Pereira (Medina del Campo, c. 1500) cuya *Nova veraque medicina* (Medina del Campo, 1558)²⁰ se enfrentó abiertamente a la doctrina sobre las fiebres preconizada en los textos de Galeno. Su postura sobre el concepto de fiebre lo llevó a enfrentarse al predominante galenismo de la época, cuyos planteamientos dominaban el panorama de la ciencia médica vigente. Su texto plantea una de las críticas más precisas a las contradicciones que presentaba la idea galénica de la fiebre. Las críticas que expone se centran en exponer el supuesto desconocimiento de Galeno sobre la esencia, causas y especies de la fiebre. En su opinión el exagerado e irregular «calor febril» no se distingue del atemperado y constante «calor natural» por su índole, sino tan sólo por su intensidad. La calentura, en consecuencia, debía entenderse como un esfuerzo de la naturaleza individual para restablecer la salud²¹.

El estudio de esta patología continuó a cargo de Fernando Mena (1520-1585) catedrático de Alcalá y médico de Felipe II²², en su *Methodus februm* (1568)²³. Lo siguieron Francisco Vallés (1524-1592) entonces joven catedrático complutense de Prima, realizando un comentario al texto galénico sobre las diferentes fiebres: *Commentaria in libros Galeni de differentis februm* (1569).

Otro fue Pedro Mercado, catedrático de Granada²⁴, autor del *De febrium differentis* (1581)²⁵. Es un texto muy tradicional, de carácter preferentemente clínico y enmarcado en el galenismo de la época. Su visión de la fiebre es que se trata de un *calor preternatural, que surge de lo más íntimo, acre y mordaz, y que afecta a la estabilidad vital del corazón y de las arterias*. Se organiza en once tratados, de los cuales el primero es el más extenso, centrado en estudiar la fiebre desde un punto de vista general, sus distintos tipos, causas, signos y remedio. Los siguientes se centran en formas específicas de fiebre, estudiándolas en tres aspectos: causas, signos y curación. Lo hacen por este orden: efímeras o diarias, continentes, hécticas, marasmáticas²⁶, pútridas, coléricas, pituitosas o flemáticas, melancólicas, pestilenciales y compuestas.

El *De febrium essentia, defferentis, causis, dignotione et curatione* (1586)²⁷ de Luis Mercado (1525-1611)²⁸ también médico de Felipe II y catedrático vallisoletano, abordó de manera monográfica el problema de la naturaleza de la fiebre. Se ocupó de sus diferentes formas y causas, clasificándolas siguiendo el modelo galénico, en efímeras, hécticas y pútridas, aunque incluyendo también las que llamó pestilentes. Sus razonamientos constituyen el intento más notable de conciliar las ideas averroístas con las del galenismo tradicional. Su prestigio lo llevó a ejercer una notable influencia en tratadistas españoles del seiscientos como Pedro García Carrero, Pedro Miguel de Heredia y Henríquez de Villacorta, Gaspar Caldera de Heredia o Gaspar Bravo de Sobremonte, quienes se decantaron por la más estricta ortodoxia en este aspecto²⁹.

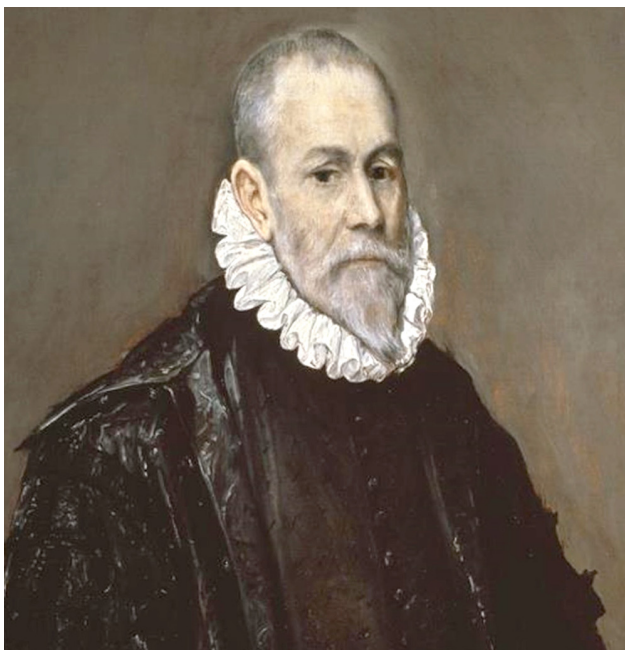

Retrato de un médico del XVII, obra de Domenikos Theotokópuli, conocido como El Greco. Representa el prototipo del médico del siglo XVII. Es muy probable que se trate del Dr. Luis Mercado, el médico más importante e influyente de la época.

La presencia habitual de la fiebre en la práctica médica diaria determinó que su atención quedase atestiguada como uno de los focos de preocupación constante de los médicos, como refleja la abundancia de obras dedicadas a este tema. Esa aplicación intelectual dio como resultado una elevada cifra de tratados dedicados a esta cuestión en la literatura médica de la época. Su número resulta un testimonio manifiesto de la frecuencia y gravedad alcanzada por los procesos febriles en la cotidiana realidad sanitaria española del siglo XVII, trasluciendo la importancia que los médicos concedieron a su estudio. La motivación y explicación patológica que la mayor parte de estos profesionales aceptaron casi sin excepción, responde a las doctrinas aprendidas siguiendo a Galeno y Avicena y las teorizaciones que sobre ellas habían elaborado los médicos españoles del siglo anterior.

La persistencia del problema clínico planteado por las fiebres en la tarea médica cotidiana, determinó la continuidad de los estudios sobre ellas. Las distintas variedades de fiebres intermitentes³⁰, tercianas y cuartanas³¹, de aparición epidémica en ocasiones, constituyeron una de las preocupaciones principales que continuarían afectando a los médicos durante el siglo XVII. La orientación diagnóstica de un tipo u otro fue a menudo causa de enconadas discusiones entre los médicos, no siempre mantenidas por razones meramente intelectuales. Un ejemplo de éstas disputas, se dio con motivo de una epidemia que afectó la villa de Epila (Zaragoza) en 1638, la cual sería identificada como fiebres ardientes por Mateo Herrero³². Otro de estos enfrentamientos sería el producido con motivo de la discusión sobre la decisión de identificar como pestilente o maligno cierto proceso febril padecido por un vecino de Villarejo de Salvanés (Madrid) en 1674. Protagonizaron el enfrentamiento por esa causa Damián de Mayorga y Guzmán³³ y Juan Bernés³⁴.

Fruto de esta preocupación van a ser los diversos tratados sobre las distintas clases de fiebres que se publicarán durante esa centuria. Un nutrido grupo de prestigiosos autores, se esforzará por realizar cuidadas descripciones de sus numerosas y diferentes variedades. Entre ellos figuran catedráticos de las principales Facultades de Medicina castellanas y afamados Médicos de Cámara de los distintos reyes que encabezaron la monarquía hispana.

Entre los estudios iniciales dedicados a las «fiebres» realizados en el seiscientos, figuran los que incluyeron en sus tratados tres maestros alcaláinos: Pedro García Carrero (ca. 1555-1628), Pedro Miguel de Heredia (ca. 1580-1655) y Francisco Henríquez de Villacorta (1615-1680). El primero es autor de *Disputationes medicae, et comentaria in fen priman libri quarti Avicenna*, (1611)³⁵. Sus páginas se ocupan en definir la fiebre, examinando sus posibles causas y estableciendo una

clasificación de los procesos febriles. En ellas se analizan pormenorizadamente sus motivaciones, sus diversas manifestaciones clínicas, las normas generales a que ha de atenerse su curación y el cuidado requerido por los «accidentes» que pueden surgir en su curso. La diferencia entre esos «accidentes»³⁶ o síntomas con que se expresaba la dolencia, era explicada por la diferente mezcla que del humor causante se producía con los otros tres restantes. La fluctuación de la intensidad o tipo de los mismos, se entendía dependiente de si dichos vapores o flatos estaban inmóviles en el interior del cuerpo o se movían. En el primer caso no causaban síntomas y la persona se sentía contenta y alegre, pero si se desplazaban hacia otra parte u órgano corporal, causaban síntomas característicos y propios del órgano que afectaban. Si alcanzaban el corazón, por ejemplo, ocasionaban palpitaciones (taquicardia) e incluso un síncope, contemplado entonces como la consecuencia de un padecimiento o enfermedad cardíaca. Así podemos verlo expresado en el *Liber de Arte Medendi* (1564) de Cristóbal de Vega (1510-1573) donde se declara precisamente: *Siquidem syncope passio cordis est.*³⁷

García Carrero describe diversos tipos de «Fiebres», desde las efímeras, a las pútridas e intermitentes. Entre los tipos especiales³⁸ cita la singultosa³⁹, vertiginosa⁴⁰, ardiente⁴¹, sanguínea⁴², flemática, sincopal⁴³, epiala⁴⁴, y lípica⁴⁵. El estudio de la pútrida viene encabezado por una erudita disertación sobre el proceso de putrefacción. Los fundamentos doctrinales en que se apoya su autor proceden de las obras de Galeno y Avicena, siendo también manifiesto el influjo ejercido sobre su obra por las opiniones de Jean Fernel (1497-1558)⁴⁶ y Luis Mercado⁴⁷.

Pedro Miguel de Heredia dedica al estudio de las fiebres todo el primer volumen de su *Operum medicinalium*⁴⁸. Su amplia descripción, apoyada por un importante soporte erudito, se apoya sobre todo en las autoridades de Hipócrates, Galeno y Avicena. El texto de la primera parte del volumen examina problemas de índole general, con especial preferencia por los etiopatogénicos. La segunda aborda la descripción particularizada de las diversas formas de manifestación de las fiebres. Realiza una cuidada exposición de la fenomenología clínica de cada una de ellas, su posible motivación y los distintos recursos terapéuticos para su curación. En esta segunda parte hace también un completo estudio de la denominada fiebre hética, las fiebres intermitentes⁴⁹ y las perniciosas⁵⁰.

Las exposiciones de Francisco Henríquez de Villacorta y Matías de Llera se atienen a lo descrito por los autores ya nombrados, siendo evidente en ambos una completa aceptación de las doctrinas galénicas. Henríquez de Villacorta (Alcalá de Henares, 18 de octubre de 1616-1680) catedrático en la facultad de Medicina de su ciudad natal, alcanzó notoriedad por sus especulaciones en defensa de Galeno realizadas en sus tres volúmenes

titulados *Laureae Doctoralis Medicae Complutensis*, publicados en 1670, 1680 y 1688⁵¹. El tema de las fiebres lo abordó especialmente en el tercero de ellos, donde realizó un comentario al *De método medendi galénico*⁵².

El aragonés Matías de Llera, natural de La Corvilla (Zaragoza) estudió Medicina en la Universidad zaragozana, obteniendo el grado de doctor y entrando a formar parte del colegio profesional en 1650. En octubre de 1652, era catedrático de «Aforismos» y posteriormente de la Segunda cátedra de curso, de la de Vísperas y desde diciembre de 1676, de la de Prima. Fue también médico de cámara del rey Carlos II y de D. Juan de Austria. En su *Manus medica dextera*, adscrito al galenismo más genuino, comentó el galénico *Sobre la diferencia de las fiebres galénico*⁵³.

El Protomédico de Cámara de Felipe IV Juan Gallego Benítez de la Serna (m. Madrid, 1647) destaca por sus descripciones de la calentura ardiente exquisita⁵⁴ y de las fiebres pútridas en la obra que publicó en 1634⁵⁵. Contribuyó también al estudio de las distintas fiebres Cipriano de Maroja (San Esteban de Gormaz, Soria, 1589 – ¿1666?)⁵⁶ autor de un *Tractatus de febrium naturalium comuni et singulari...* (1641)⁵⁷. Constituye un completo estudio de los distintos procesos febriles a lo largo de los cinco «Libros» que lo integran. Los ordena en cuatro especies, tratando de sus causas, pronósticos y precisando los procedimientos curativos habituales. En su descripción destaca las fiebres intermitentes, en especial las que denomina tercianas exquisitas y dobles⁵⁸. Otros estudios sobre las fiebres figuran en el *Espejo de la Philosophia* de Juan de la Torre y Valcárcel⁵⁹, cuya descripción de la fiebre se atiene asimismo al galenismo tradicional.

Gaspar Bravo Ramírez de Sobremonte (1610-1683) médico de cámara de Felipe IV y Carlos II estudió especialmente la clínica de los procesos febriles. Expuso los resultados de sus observaciones en una amplia teorización titulada «De febribus et earum curatione» incluida en su *Resolutionum medicarum circa vniuersam totius physiologiae doctrinam* (1649)⁶⁰. En su revisión de las manifestaciones febriles defiende la doctrina dogmático-racional, enfrentándose a las opiniones de autores alineados en las escuelas empíricas, paracelsistas y vanhelmontianas⁶¹. Su escrito sobre la naturaleza de la fiebre, expone su posible motivación causal, la fenomenología clínica y el tratamiento de la fiebre *efémera* (sic) o diaria, la fiebre hética y las denominadas fiebres humorales. En este último grupo distingue la fiebre «synocha», la «synocha pútrida», la fiebre ardiente terciaria, la terciaria «exquisita», la terciaria «notha», la fiebre cotidiana y la cuartana.

Este autor vuelve a tratar el tema de las fiebres en el tercer volumen de su *Operum medicinalium*⁶² que dedica a los siguientes problemas, por este orden: las

fiebres intermitentes, la crisis y los días críticos, y una parte final de temas muy variados tocantes a la Medicina. En su exposición analiza las llamadas en la época «fiebres intermitentes perniciosas», fiebres cotidiana, terciana y cuartana. Incluye también la descripción de las fiebres pestilenciales⁶³, sincopal, quintana y septana, la intermitente «colliquante» y otras variedades de fenomenología clínica menos precisa. Se refiere asimismo a las complicaciones que pueden modificar la evolución habitual de las fiebres intermitentes. Finalmente menciona los procesos febriles a los que cabe reconocer origen divino o sobrehumano y cuya curación, por tanto, solo puede lograrse con recursos ajenos a la intervención profesional del médico.

Cada una de las diferentes formas clínicas mencionadas, es expuesta por Bravo de Sobremonte de acuerdo con los mecanismos etiopatogénicos que considera sus causantes. Describe respectivamente la peculiar sintomatología de cada una, su diagnóstico y pronóstico, concluyendo con el abanico de recomendaciones terapéuticas. Dedicó un estudio particular a la exposición de la fiebre terciana y sus variedades y otro, asimismo amplio, a discutir las normas que deberán presidir el tratamiento de cualquier proceso febril. Las ocho secciones del escrito contienen una descripción de los recursos farmacológicos y normas dietéticas a seguir, determinando el uso de sangrías y purgantes. Expone también una serie de consejos para la curación de las más comunes complicaciones o «accidentes» de un proceso febril. Concluye la exposición con una nueva incursión de su autor en el terreno clínico, describiendo algunos tipos de fiebre de aparición no frecuente, como serían la fiebre reumática y las fiebres lenta, sincopal y la que denomina «pútrida lumbrical»⁶⁴.

Otras contribuciones sobre las fiebres hechas en el siglo XVII, son los comentarios a textos piretológicos galénicos, como la *Disputatio de natura febris* (1606) de Diego Rodríguez Guerrero⁶⁵, o los del gallego Benito Matamoros Vázquez, Pedro Camañes, Juan Francisco Rossell y Juan Bautista Navarro.

Matamoros defiende en sus *Selectarum medicinae disputationum...* (1622)⁶⁶ las opiniones de Galeno y Avicena, criticando los criterios que considera contrarios a la tradición del galenismo arabizado representado por autores como Gómez Pereira, Fernel⁶⁷, Vallés⁶⁸, Cristóbal de Vega⁶⁹ y Mercado. La obra expone su argumentación en cuatro «Libros». El primero se centra en establecer la esencia de la fiebre y sus diferencias, mientras que el segundo aborda el abanico de sus posibles etiologías. El tercero está esencialmente dedicado a las fiebres diaria y héctica, mientras que el cuarto se ocupa exclusivamente del estudio de las fiebres pútridas.

Pedro Camañes (1625) hace también defensa de la doctrina sobre las fiebres formulada por Galeno⁷⁰.

Seguidor asimismo de la doctrina galénica es el estudio del médico barcelonés, político y cronista de la Corte de Felipe III, Josep Francesc Rossell (Barcelona, c. 1560-c. 1641) publicado en 1627⁷¹. Aportaciones en la misma línea de pensamiento serán las de Juan Bautista Navarro (1628)⁷² o de Sebastián Soto (1638)⁷³. A mediados de siglo se publica en Valencia el texto de Vicens Garcia Salat *Utilissima disputatio de dignotione et curatione febrium* (1652)⁷⁴ reimpreso en 1656 y 1682. En estas reimpresiones su obra incorpora nuevos capítulos dedicados al tratamiento de la fiebre pestilente y las fiebres terciana y cuartana. En 1663 aparecen las *Febriologiae lectiones pincianae...* de Juan Lázaro Gutiérrez⁷⁵, donde describe la naturaleza y diversidad de las fiebres y sus causas. Para explicar su génesis, revisa los conceptos de los procesos de cocción y putrefacción, fundamentando su opinión en los criterios de autoridad habituales, al tiempo que comenta algunas de sus variedades clínicas. Finaliza su exposición mencionando los criterios terapéuticos que deben seguirse para su tratamiento y curación⁷⁶.

Francisco Duarte Méndez se ocupó del protocolo del tratamiento a seguir en las fiebres pútridas, publicando en 1648 un escrito dedicado a establecer si en esos casos era mejor purgar a los pacientes antes de recurrir a la sangría⁷⁷. Este tipo de fiebres contó también con la destacada descripción dedicada a su tratamiento mediante el uso de sangrías y purgantes, hecha en 1678 por Juan Bautista Orivay de Monreal⁷⁸.

A estas exposiciones incluidas en tratados generales, hay que sumar destacados estudios monográficos centrados en una sola variedad de calentura, concretamente la de las fiebres tercianas. Entre estos últimos destacan el de Pedro Barba⁷⁹, *Vera praxis ad curationem tertianae...* (1642)⁸⁰ y el de Leonardo Salvador de Flores *Desempeño al método racional en la curación de las tercianas notas* (1693)⁸¹. Ambos escritos fueron cuestionados y sus proposiciones objeto de acusadas polémicas y enfrentamientos.

En el primer caso, el texto formó parte de una polémica surgida tras la crítica realizada por cierto médico flamenco llamado Martin Soers al tratamiento de la fiebre terciana mediante corteza de quina por Pedro Barba⁸². A su favor intervino Cristóbal Tristán de Acuña (1642)⁸³. Su prestigio reside en haber sido el primero que escribió sobre el uso de la corteza de quina como febrífugo, en la obra citada, suscitando una polémica entre partidarios y detractores de su aplicación. A favor de su uso como febrífugo se pronunció Diego Salado Garzés (1679)⁸⁴.

Salvador Leonardo de Flores (Sevilla, s. m. s. XVII – ?, p. m. s. XVIII) médico posicionado en las tendencias *novatoras*, se mostró también decididamente a favor de los nuevos recursos farmacológicos llegados de las tierras suramericanas. Concretamente de la quina, que

utilizó para combatir una supuesta epidemia de tercianas padecida en Sevilla en la última década del seiscientos⁸⁵. Sus prescripciones suscitaron una aguda réplica⁸⁶ por parte de Alonso López Comejo⁸⁷ a la que respondió Flores con un texto titulado *Antipología médica*, publicada en 1705⁸⁸. La historia de la introducción de la quina en la Península para el tratamiento de las fiebres intermitentes es narrada en el capítulo final de esta última obra⁸⁹.

El proceso febril calificado de «calentura maligna», considerado no pestilencial, es mencionado por Cipriano de Maroja en su obra ya nombrada⁹⁰. El diagnóstico diferencial que debe establecerse, según la mentalidad clínica de la época, entre fiebres pestilenciales y malignas es formulado por Juan Lázaro Gutiérrez⁹¹. Sobre el pronóstico y tratamiento de la fiebre maligna realizó un destacado estudio el aragonés Tomás Longás titulado *Enchiridion novae et antiquae Medicinae dogmaticae, pro curatione febris malignae* (1698). Su tratado toma las fiebres padecidas por el Duque de Villahermosa como motivo para exponer sus convicciones sobre la iatroquímica, a la cual pretendía incardinar en el sistema médico galénico⁹².

Juan Nieto Valcárcel y Félix Osona realizaron descripciones de brotes epidémicos de fiebres malignas. Nieto de Valcárcel estudió la fiebre pestilente y maligna denominada tabardillo, de carácter endémico, que suele cursar de manera aguda y grave⁹³ y la epidemia de fiebres malignas padecida en Valencia desde 1675. Intervino activamente en ella con el entonces innovador tratamiento mediante los «alexifármacos sudoríficos», cuyo uso defendió encarecidamente⁹⁴. Osona dedicó varios escritos a la epidemia de fiebres malignas padecida en Vich en 1684⁹⁵ y el uso de la sangría en estas patologías de predominio febril⁹⁶. Su libro suscitó una viva polémica, siendo criticado con dureza por algunos otros médicos de dicha ciudad. Entre otros críticos, destacaron el médico y filósofo Ignasi Moreta⁹⁷ y el médico Marcià Homs⁹⁸, entre otros. Félix Osona respondió a esas críticas en su *Appendix tractatus de febre...* (1700)⁹⁹.

El autor: Rafel Rapó i Font

Rafel Rapó i Font (Sineu (Mallorca) 1645- m. Porreres (Mallorca) 26. VIII.1710) era hijo del médico Bartomeu Rapó y de Margalida Font y hermano del también médico Miquel Rapó Font. Formaban parte de una familia de médicos y boticarios de Sineu, en la cual se contaban otros intelectuales.

Obtuvo el grado de Doctor en medicina el 21 de agosto de 1677, por lo que no figura en el listado académico de la entonces aún no activa Facultad de Medicina de Mallorca¹⁰⁰. Es presumible que lo hiciera en otra Facultad de Medicina, acaso la valenciana de la cual menciona

a varios profesores en su texto y a la cual acudían numerosos mallorquines.

Apenas tenemos noticias de su trayectoria profesional, sin duda porque transcurrió en buena parte fuera de la isla, prestando servicio en la Real Armada de Carlos II. A lo largo del mismo debió alcanzar el grado de capitán que figura en su acta de defunción.

Algunos autores le atribuyen haber desempeñado el cargo de *morber* de Ciutat de Mallorca¹⁰¹. Es posible que en realidad se tratara del cargo de Médico de la Morberia, cargo técnico y permanente, asesor de los *morbers*, cuyos cargos por elección se renovaban periódicamente. Las tareas desempeñadas por los que eran nombrados para este último cargo no requerían ningún conocimiento de medicina en especial. Su cometido se limitaba a supervisar el cumplimiento de la legislación sanitaria y a controlar la entrada de mercaderías y llegada de pasajeros o visitantes a la isla.

En el *Stim* o catastro de 1685-86 dos hermanos médicos, llamados Rafel y Miquel Rapó, ambos naturales de Sineu, aparecen residiendo en una gran casa situada en la parroquia de Sant Miquel. El primero de ellos parece tratarse de nuestro autor y el segundo su hermano. Otro miembro de esa familia era un doctor en medicina llamado Miquel Rapó, que figura con ese título en el inventario de bienes post-mortem de su hermano, el boticario Martín Rapó, realizado el 6 de enero de 1657¹⁰². Parece que no se trata del hermano del doctor Rafel Rapó (m. 1710) al que parece referirse el catastro de 1685, sino que se trataría de otro Miquel Rapó, también doctor en medicina y de cuyos bienes se hizo inventario *post mortem* el 7 de octubre de 1669. Entre las propiedades que aparecen en ese listado, figura una casa que tenía alquilada en Sineu, donde probablemente debía residir, al menos temporalmente. En dicho listado, se mencionan *25 llibres de medicina, ço és, les obres de Galeno, Hipocrates, Mesué y altres...* *Aquests llibres ja els tenia el doctor en medicina Rafel Rapó, parent del difunt*¹⁰³.

En 1685 Rafel, autor de la obra que nos ocupa, era el médico de la Morberia, importante institución sanitaria mallorquina, encargada de controlar la epidemiología local y la sanidad exterior. Ambos hermanos serían la generación siguiente a la de los hermanos del mismo apellido, Martí, boticario, y Miquel, médico, fallecidos en 1657 y 1669. Tal vez fueran descendientes de otro médico llamado también Rafel, citado en pasado, probablemente por haber fallecido, en el inventario de los bienes del médico hecho en 1669¹⁰⁴.

Entre sus familiares se contaban otros intelectuales y sanitarios, tales como el teólogo Martí Rapó Garí y el *apotecari* Martí Rapó (m. 1657). Este último en 1634 tenía farmacia abierta en Sineu, donde ejercía además

como *cerer*, como aún era costumbre en la época. Así lo apunta que en el año mencionado consta que vendía velas a ciertos peregrinos. Además en el inventario de sus bienes realizado tras su fallecimiento, donde se incluye el de su obrador de farmacia se mencionan instrumentos propios de esa competencia, tales como *un morter gran, dos petits de coure, un parol gran y un petit per fer cera*¹⁰⁵. Otro pariente fue el teólogo Martí Rapó Garí (15 de febrero de 1642-10 de diciembre de 1713) graduado en Sagrada Teología, rector de Sant Miquel de Palma y posteriormente de Porreres. Falleció con fama de santidad, estando sepultado en la capilla de Ntra. Senyora del Roser de Sineu¹⁰⁶.

Nuestro autor redactó diversas obras literarias, la mayoría aparentemente perdidas. De ellas se conoce una pieza teatral, redactada en catalán (1680) localizada y editada por Reus Belmar (1994). En ella elogia la casa de Austria, para celebrar el matrimonio entre Carlos II y María Luisa de Borbón. Ha sido considerada un texto dramático de estilo barroco¹⁰⁷.

La obra

Apollineum Majoricense bellum contra febres perniciosas (1707) es la única obra médica conocida de Rapó. Va precedida por una dedicatoria, un prólogo destinado al lector (*Ad charissimum lectorem*) y la justificación de la correspondiente censura religiosa.

La ofreció a uno de los personajes mallorquines más distinguidos y prestigiosos de la época. En la dedicatoria nos recuerda sus numerosos títulos: *Al Illvstrissimo Señor Don Ivan Antonio de Pax, y de Orcao, olim de Boxadós, y de Pinós, Conde de Zavellà, ... del Consejo de su Majestad, su ayudante General y su plenipotenciario, como también Virrey, y Capitán General en el Reyno de Mallorca e islas adyacentes*. Rapó, en esa dedicatoria al Conde de Zavellà, identifica el texto como un «Diálogo de Calenturas Malignas y perniciosas, vulgarmente llamadas Tabardillos», en apariencia por estar redactado en forma de preguntas y respuestas. Lo declara el resultado de su *frecuente estudio, y dilatadas experiencias dispusieron para la universal utilidad del linaje humano*¹⁰⁸.

La obra fue debidamente censurada por orden del Obispo de Mallorca Francisco Antonio de la Portilla. Se encargó de ello el P. Fr. Guillem Homar, Maestro en Sacra Theologia en la Diócesis de Mallorca, Examinador Sinodal y Rector del Real Convento de Predicadores de Mallorca, fechándola el 21 de febrero de 1707.

La obra se articula en torno a un único tratado, dedicado exclusivamente a la fiebre llamada terciana perniciosa. Está dividido en cuatro «preguntas» (*quaestio*), manteniendo una estructura al modo de la enseñanza medieval de preguntas y respuestas (*quaestiones et*

responsiones). Estas preguntas se subdividen a su vez en lo que denomina «artículos».

Las cuatro partes de la exposición abordan otras tantas cuestiones (*Quaestio*) concernientes al problema de las fiebres. La primera de ellas trata de la naturaleza y etiología de las fiebres, incluyendo el lugar donde pueden generarse y del modo como se producen. En su opinión, aunque la calentura afecta a todas las partes del cuerpo, está originada en un solo lugar, desde donde se irradia al resto del organismo. Dicha localización la identifica con el órgano afecto por la enfermedad, manteniendo en este sentido, una opinión divergente de la mantenida hasta entonces sobre el origen de las fiebres, que se estimaba causado por enfermedades que afectaban a todo el organismo (*totius substantiae*). La segunda aborda la fiebre perniciosa o maligna, llamada más tarde atáxica y sus clases. En este apartado se incluyen la terciana, los signos premonitorios y de estado, las consecuencias de la misma o "accidentes" y la fiebre pestilencial contagiosa. La tercera se ocupa de la fiebre terciana llamada intermitente y sus clases, terciana benigna, sinoca, sinoca serosa, terciana perniciosa y los respectivos tratamientos que deben aplicarse en cada una de ellas. Una de las opciones terapéuticas que analiza, son las sangrías y la localización anatómica vascular donde deben realizarse¹⁰⁹. La cuarta es un manual de tratamiento de los eventuales accidentes o consecuencias que pueden originar, respectivamente, cada uno de los tipos de fiebres. Un apéndice dedicado a la «calentura héctica», conocida también con el nombre de *fiebre lenta*¹¹⁰ completa el cuadro de las calenturas estudiadas.

La pregunta o *Quaestio* primera se ocupa *De la naturaleza y género de la fiebre*, analizando la modalidad de «calentura pútrida», más adelante conocida como *adinámica*. Principia sus explicaciones sentando las bases de lo que entiende por fiebre y el lugar del cuerpo humano donde se sitúa su causa. Dedicó a este tema tres artículos, el primero de los cuales corresponde a un «Proemio». Destina el segundo a la consideración *Del lugar donde existe un foco de fiebres pútridas*, a partir del cual se *irridia* (sic) invadiendo luego el resto del cuerpo. En el tercero describe la manera en que se genera la variedad de fiebre pútrida denominada *notha*¹⁰¹.

La segunda pregunta se centra en la fiebre terciana perniciosa y maligna¹¹², dicha más adelante *atáxica*, a la cual dedica seis artículos. Comienza por tratar de establecer lo que es y los tipos que existen de fiebre perniciosa, para continuar con los mecanismos de la generación de esas fiebres y su origen. Explica el papel que en su malignidad y perniciosidad tienen los humores, en especial en las causadas por el humor bilioso. Determina los signos antecedentes y concomitantes que permiten diagnosticarla y los «accidentes» que pueden presentarse según el origen de su generación. Finaliza

discutiendo si la fiebre perniciosa es contagiosa y si puede volverse fiebre pestilente.

La tercera parte está dedicada a los tratamientos que se prescribirán para los distintos tipos de fiebres tercianas¹⁰³, a cuya descripción dedica seis artículos. Inicia sus recomendaciones con los tratamientos a seguir en los casos fiebres tercianas benignas y la perniciosa, así como la fiebre ardiente. Seguidamente se ocupa de la variedad de fiebre llamada *synoca*¹¹⁴, así como de su causa, esencia y curación, pasando luego a la variedad de fiebre sinoca llamada *serosa*¹¹⁵, abordando su diagnóstico y tratamiento. Termina este apartado con los tratamientos de la fiebre terciana perniciosa¹¹⁶ mediante lo que denomina *remedios menores*, antes de pasar a recurrir a la sangría y la purga, a las cuales considera *remedios mayores*.

La cuarta y última sección es la más extensa de todas, siendo desarrollada en trece artículos. Está dedicada a tratar de la curación de los accidentes funestos que pueden sobrevenir en la fase de remisión de las calenturas, sobre todo si han sido particularmente graves¹¹⁷. Se centra en el tratamiento de los accidentes que se considera quedan como secuelas de la fiebre perniciosa¹¹⁸. El apartado se inicia discutiendo si las fiebres tercianas benigna y maligna deben tratarse en ambos casos con el mismo método medicinal. El segundo artículo está dedicado a los accidentes que siguen a una fiebre perniciosa (mortal) y si deben ser tratados regularmente con los mismos remedios y observando las mismas indicaciones. Asimismo expone cómo debe administrarse y cuál deberá ser el tratamiento de la fiebre a la que siguen y los origina. Los cinco siguientes se ocupan de la curación de cada uno de los diversos accidentes de este tipo. El primero de este grupo lo hace concretamente del dolor pleurítico, indicador de una pleuritis residual subsiguiente a la fiebre terciana perniciosa, mientras que otro lo hace con el catarro que deja como secuela. Continúa con los tratamientos a aplicar en los casos en que se presenten vómito, náusea e hipos o si se presenta un síncope. También se ocupa de los que se aplicarán a patologías de origen cerebral, que actualmente incluiríamos entre las de tipo psiquiátrico. Entre éstas menciona Letargia (somnia estuporosa), Vigilia (insomnio), Parafrenitis (estado confusional) y Delirio, que se producen en los casos de rebrote o recaídas de la fiebre terciana perniciosa y sus consecuencias. Los siguientes están dedicados a la curación de la fiebre lipiria y si esta fiebre o cualquier otra fiebre maligna o terciana perniciosa, pueden llegar a desaparecer temporalmente o de forma definitiva. Informa asimismo del tratamiento a observar en las diarreas (*excreciones intestinales*) en la [fiebre] colicuativa y del tratamiento o curación que debe seguirse en los casos de inflamación de las parótidas. Culmina este apartado describiendo la naturaleza y métodos de cura que se

aplicarán en los casos de las fiebres pestilentes y las fiebres hécticas.

La obra se cierra con un apartado con el título *Final y conclusión del Opúsculo de las fiebres*. Nuestro autor explica que lo expuesto son las cosas que se ha atrevido a exponer acerca de las fiebres perniciosas. Admite haber deseado *hacerlo más y mejor*, considerando que tal vez podría haberlo logrado si las dimensiones de lo que hubiera podido redactar no hubieran podido acarrearle críticas. Por ello remite a sus lectores a los escritos de autores anteriores, si bien reconociendo que sus compatriotas médicos deseaban que escribiese esos textos. No obstante, recuerda el pasaje del Evangelio de San Lucas (4, 25) donde menciona que ningún profeta es aceptado en su patria. No obstante haberse manifestado *libremente todas las cosas que he dicho en este breve diálogo sobre las fiebres*. Culmina su escrito manifestando que lo somete a la *corrección y patrocinio de la Sacrosanta Iglesia Católica Romana y que lo ha destinado a honor y alabanza de la Santísima Virgen Madre sin mancha, vencedora de todos los males*.

Obras y autores citados

El autor invocado con mayor frecuencia, como era de esperar es la incontestable autoridad de Galeno de Pérgamo, cuyo nombre y obras aparecen en doscientas trece ocasiones. Sus tratados más citados son mencionados en sus páginas como *De ratione victus*¹¹⁹; *Differentis febris*¹²⁰; *Liber de marcore*¹²¹ y el *Methodus medendi*¹²². El segundo de los autores con mayor incidencia en el texto que nos ocupa es Hipócrates, de acuerdo con todas las previsiones esperables en un autor claramente inscrito en la línea del «galenismo hipocratista». Su nombre o menciones a sus doctrinas se aluden en cerca de centenar y medio de ocasiones.

El afamado y prestigioso catedrático vallisoletano Luis Mercado (León, 1525-Valladolid 1611) es el tercero de los autores más nombrados, con veintiséis menciones nominales directas. Formado en Valladolid y catedrático de su Facultad de Medicina desde 1572, fue médico de cámara de Felipe II que le nombró Protomédico General. Defensor riguroso de los principios del galenismo, sus opiniones influyeron de forma significativa en los presupuestos escolásticos contrareformistas. Su reiterada presencia entre los autores invocados por Rapó, la justifica de forma cumplida su destacada obra sobre las fiebres malignas¹²³.

En el grupo de autoridades cuya presencia destaca en la obra que nos ocupa, sigue a los anteriores el catedrático alcalaíno, titular de la silla de Prima, Pedro Miquel de Heredia (Toledo 1580- Madrid 1655). Formado en esa universidad y más adelante médico de Felipe IV, se inscribe entre los galenistas moderados, con notables

influencias del paracelsismo y las corrientes iatroquímicas. Su presencia resulta completamente justificada, ya que el tema de las fiebres fue uno de los que más le interesaron y al cual dedicó todo el primer volumen de sus *Opera Medicinalium* (1673). Su importancia entre las generaciones de médicos posteriores lo demuestran las repetidas reediciones que dichas obras conocieron en los años siguientes de su centuria¹²⁴.

Con importancia menos relevante aparece también en las páginas de Rapó, Gaspar Caldera de Heredia (n. Sevilla 1591, m. post 1688). Formado en la facultad de Salamanca, ejerció como médico en Carmona y desde 1633 en Sevilla, donde fue médico del conde de Niebla. Es una de las figuras más destacadas del galenismo «moderado» en la España de mediados del siglo XVII. Al igual que Gaspar Bravo de Sobremonte, Pedro Miguel de Heredia y otros autores de esta mentalidad, aceptó novedades procedentes de las corrientes modernas como rectificaciones parciales de las vigentes doctrinas galénicas, pero sin abandonar el sistema médico tradicional. Notablemente influido por el paracelsismo, era buen conocedor de la obra de Paracelso y los escritos del «Paracelsian Revival», auspiciados por los quimiatras de la primera mitad del siglo XVII. Lo estuvo también por las ideas de autores eclécticos como Daniel Sennert, a todos los cuales citó repetidas veces en sus obras. Igual que otros galenistas moderados incorporó plenamente los medicamentos químicos e incluso la interpretación iatroquímica de la acción de algunos remedios tradicionales, como el opio. Al mismo tiempo, se resistió a introducir la quimiatria en los saberes patológicos, que continuó exponiendo y explicando de acuerdo con las doctrinas galénicas. Solamente en alguna afección determinada, como la gota, admitió parcialmente la teoría paracelsista de las «enfermedades tartáricas»¹²⁵.

Rapó menciona también, en no menos de nueve ocasiones, al médico y filósofo Daniel Sennert (1572-1637) de modo explícito. Este autor, doctorado en filosofía (1598) en la Universidad de Wittenberg, se centrará posteriormente en el estudio de la medicina, que enseñará en su correspondiente facultad de dicha universidad desde 1602. Destaca por su introducción del estudio de la química y los recursos de la misma con fines terapéuticos, como preconizaban los paracelsistas y iatroquímicos. Su fama como médico lo llevó a ser nombrado médico personal del príncipe Johann Georg I de Sajonia.



Considerado un convencido aristotélico al inicio de su vida intelectual, sus obras más tempranas, como el *Epitome naturalis scientiae* (Wittenberg, 1618 y editado en inglés: Londres, 1661) demuestran su disposición a admitir las ideas de los novatores, siempre que se hallara evidencia “probable” de las mismas frente a la certeza que concedía a las doctrinas aristotélicas. Su referencia en la presente obra parece obligada más que por las aportaciones mencionadas, por el peso de sus escritos sobre las fiebres en el entorno europeo de la centuria del seiscientos. Las numerosas ediciones de su *De febribus, libri IV*¹²⁶, bien en solitario o asociado con su *Epitome institutionum medicinae*¹²⁷, su tratado de disentería¹²⁸, o con un escrito sobre el tratamiento de la peste¹²⁹, justifican sobradamente su presencia. Dicho tratado es considerado una de sus mejores obras y sus no menos de diecisiete ediciones en diferentes ciudades europeas¹³⁰, principalmente en Wittenberg, entre 1619 y 1664, lo convierten en el texto dominante sobre las fiebres durante todo el seiscientos.

Otro autor cuyos escritos sobre fiebres alcanzaron una importante difusión es el médico Giovanni Michaele Savonarola (Padua, 1384-Ferrara, 1464). Ejerció inicialmente en su ciudad natal, donde consolidaría su fama profesional y docente. Hacia 1440 se trasladó a Ferrara dedicándose a la enseñanza de la medicina durante diez años. Allí sería nombrado médico de la corte de los Este, con dedicación exclusiva a la salud del duque Leonello y el duque Borso, a cuyo servicio permaneció hasta su muerte. Su obra principal es *Practica de egritudinibus a capite usque ad pedes* o *Practica maior*, manual de medicina práctica redactado entre 1440 y 1446¹³¹.

Fue un autor prolífico, cuyos intereses abarcaron un amplio abanico de temas. Su presencia entre los autores a quienes recurre Rapó no es casual ya que dedicó a la fiebre una importante monografía con el título de *Practica canonica de febribus* (1487 y 1496)¹³². Su éxito y aceptación se producirá sobre todo en el siglo siguiente, siendo reeditado en numerosas ocasiones. A veces lo fue formando parte de un conjunto variable de obras de Savonarola, como en 1517¹³³ y 1543. En otras su reedición fue en solitario¹³⁴ o unido a varios tratados, a veces sobre fiebres¹³⁵, como en 1560¹³⁶ y en 1561¹³⁷ o incluso junto con importantes obras quirúrgicas¹³⁸.

Giovanni Manardo (Ferrara, 1462-1536) también llamado Manardi

o Mainardi, médico, botánico e importante humanista italiano, es otro de los autores usados por Rapó en apoyo de sus exposiciones. Docente en la Universidad de Ferrara durante diez años, en el curso de los cuales su crédito como médico le promovió a ser archiatra (médico de cámara) de los reyes de Hungría Ladislao II (1513) y Luis II (1516). A su regreso a Ferrara (1518) lo sería de Alfonso I d'Este. Su obra más destacada son sus seis libros de las *Epistolae medicinales* (1521) donde aborda cuestiones de nomenclatura histórica y discute la identificación de enfermedades y fármacos citados por los autores antiguos¹³⁹. El éxito que alcanzaron les propició una edición comentada por François Rabelais (1532) en doce libros. Ampliados en 1535, al ser impresos póstumamente por M. Isengrin en Basilea (1540) alcanzaron los veinte libros, incluyendo 103 cartas. Algunas de éstas tuvieron además una notable difusión por separado, como la dedicada a la peste (*Ep. med.*, V, 3, 1516) impresa en italiano (Ferrara, 1522).

Otro de los autores asiduamente citados, es el médico Alexandro Massaria (Vicenza, 1510-m. 1598) convencido galenista, profesor en la facultad de Medicina de Padua y con ejercicio en Venecia. Su nombre aparece en dieciseis ocasiones, con especial atención a un escrito suyo sobre peste. Parece tratarse del *De peste libri duo* (Venetiis, Apud Altobellum Salicatum, 1579) o bien en apariencia con mayor justificación, del *De abusu medicamentorum vesicantium et theriacae in febribus pestilentibus disputatio* (Patavii, Apud Paulum Meietum, 1591).

Ercole Sassonia (Padua, 1551-1607) aparece citado también como Hércules Saxonia y Hércules Saxonia Patauinus. Fue profesor en Padua y uno de los grandes clínicos italianos del Renacimiento. Su presencia entre los autores a los que Rapó recurre, la debe con toda probabilidad a su *Disputatio de phoenigmorum* (1591) donde se ocupa del tratamiento de las fiebres pestilentes mediante vesicaciones¹⁴⁰ y administración de Triaca¹⁴¹. Más adelante dedicó otro texto también al estudio de las fiebres¹⁴². Más adelante publicó *De febribus tractatus numeris omnibus absolutus* (1620) también dedicado al estudio de las fiebres¹⁴³.

El *Lupeius* que aparece entre los autores en quienes Rapó se apoya, es identificable como Alonso López de Corella (Corella, Navarra, c. 1517- Tarazona, Zaragoza, 1584). Formado en Salamanca y luego como médico en Alcalá de Henares (c. 1542). Ejerció en diversas localidades, afincándose finalmente en Tarazona desde 1560 hasta su muerte. Durante esos años publicó sus más importantes textos médicos, entre los que

nos interesa señalar su monografía sobre el tabardillo *De morbo pustulato* (1574) centrado en la patología identificada actualmente como fiebres tifoideas o tifus exantemático. Sin muchas dudas es la causa de su presencia entre los citados en las páginas del texto que nos ocupa¹⁴⁴. Fue impreso en Zaragoza (1574) como parte de un solo volumen junto al *De placitis Galeni* y *las Medicae animadversiones*, constituyendo la última aportación bibliográfica de su autor. La denominación de la fiebre tifoidea o tifus exantemático como Tabardillo, es mencionada por Rapó en un título en castellano, al parecer alternativo al ostentado por la obra.

Entre los nombrados en el texto de Rapó figura el portugués lisboeta Diego Rodrigues Sacuto (1575-1642) llamado también Zacuto Lusitano. Formado en Salamanca y Coimbra, finalizó sus estudios en Sigüenza. Ejerció provechosamente su profesión médica en Lisboa, hasta que perseguido por judío escapó a España y más tarde a Amsterdam. Es considerado el médico más destacado de Portugal en todo el siglo XVII.

Menciona a cuatro autores de territorios inmediatos. Tres son médicos valencianos y catedráticos de su facultad: Luis Collado, Juan Bautista Orivay y Monreal y Vicente García Salat (1555-1614) y el cuarto es el catalán Jacint Andreu (Hostalrich (Girona)- m. Barcelona, post 1678).



Luis Collado (Valencia, c. 1520-1589) importante maestro de la facultad de medicina valenciana y principal introductor en la Península de la anatomía vesaliana es mencionado a través de su *Isagoge* (introducción) a los textos de Hipócrates y Galeno¹⁴⁵. En ella se refleja su trayectoria hacia el galenismo hipocratista y su oposición a las ideas del galenismo arabizante, así como la importancia que adjudicaba a la *observatio* clínica¹⁴⁶.

El segundo es Vicente García Salat (1555-1614) catedrático de Anatomía y disección de la facultad valenciana, presente sin duda por su *Utilissima disputatio de dignotione et curatione febrium* (1652). La aceptación y divulgación alcanzada por dicha obra durante la etapa de actividad profesional de Rapó, fundamenta su cita como autor acreditado en el tema de las fiebres. La obra fue reimpressa con idéntico título y las correcciones oportunas en 1656 y por tercera vez en 1682. En esta última edición se amplió con la aportación de un estudio sobre el Quarango o Cascarilla, nombre que recibía la Quina, cuya importancia es bien conocida en el tratamiento de las fiebres¹⁴⁷.

El tercer valenciano citado es Juan Bautista Orivay y Monreal (1633-1682) catedrático de Filosofía y Medicina

en las aulas de su ciudad, en las llamadas de Teórica y de Hipócrates. Su presencia en las páginas de Rapó la justifica su comentario a las opiniones de Hipócrates y Galeno sobre las fiebres pútridas y el tratamiento a prescribir en esos casos¹⁴⁸. También pudo decidirlo su informe tras un comisión profesional en Orihuela, durante la epidemia de fiebres (calenturas malignas) de 1678 para establecer cuál era la enfermedad causante e informar sobre la situación. El informe que emitió, fue publicado al año siguiente y su conclusión determinó que la epidemia era de calenturas malignas y no un brote de la temida peste¹⁴⁹.

Jacint Andreu (Gerona, c. 1630 - Barcelona, c. 1694) fue a su vez catedrático de Prima en Barcelona (1653-1677) y maestro de Joan d'Alós. Médico del príncipe Juan José de Austria figura en torno a la cual se produjo la fase inicial de la renovación científica española. Contrario a las doctrinas iatroquímicas, evitó entrar en controversias, centrandose su atención en la observación clínica rigurosa, de forma muy similar a los seguidores del galenismo hipocratista. La obra de este autor a la que alude Rapó es *Practicae Gotholanorum pro curandis humani corporis morbis* (1678), aunque debemos recordar que pocos años antes de aparecer la obra de Rapó había sido nuevamente reeditada (1704)¹⁵⁰.

Solo un par de menciones corresponden a Abū-'Alī al-Ḥusayn ibn-'Abdallāh Ibn-Sīnā /Avicenna (Afshona, Uzbekistán, 970/980-Hamadán, Irán1037). Este autor era el más representativo de la medicina árabe medieval y la traducción latina de su *Canon medicinae* determinó la corriente intelectual del «galenismo arabizado». Una sola cita parece corresponder a Arquígenes de Apamea (ca. 75-129), influyente miembro de la escuela ecléctica.

Conclusiones

La obra del mallorquín Rafel Rapó i Font *Apollineum contra febres perniciosas*, fue publicada en la primera década del siglo XVIII. Aunque es mencionada en los repertorios bibliográficos locales y en algunos diccionarios médicos recientes, es ignorada por la mayoría de los manuales de historia de la medicina. Acaso porque se trata de la única obra de este autor que llegó a publicarse, ya que su también única obra teatral que conocemos, se ha conservado solo en forma manuscrita.

Natural de Sineu, hijo y hermano de médicos, pertenecía a una familia con varios miembros universitarios e intelectuales. Tras cursar medicina, tal vez en Valencia, se alistó como médico de la Real Armada, donde llegó a alcanzar el grado de capitán. Al licenciarse y regresar a Mallorca sabemos que desempeñó el cargo titular de Médico de la Morbería, institución dedicada al control de la entrada de la peste y enfermedades infecciosas

llegadas desde el exterior y susceptibles de causar epidemias en la isla.

Su libro aborda de manera monográfica el tema de las fiebres, el cual era uno de los problemas más arduos a los que se enfrentaron los médicos desde la Antigüedad hasta el Antiguo Régimen. Desde las primeras exposiciones hipocráticas y sobre todo las de Galeno, numerosos autores se plantearán el estudio y clasificación de las fiebres, como paso imprescindible para orientar su tratamiento. Este interés cobra un especial relieve en la medicina de los siglos XVI y sobre todo del XVII. La medicina española de esas dos centurias cuenta con una nutrida bibliografía sobre el tema de las fiebres. Fue un tema que mereció la atención de un grupo de los médicos más prestigiosos de esas centurias. Muchos de estos autores ocupaban puestos distinguidos en la enseñanza universitaria y/o eran médicos reales o de la nobleza, laica o religiosa. Este contexto es el que enfrenta Rafel Rapó cuando decide redactar un tratado sobre las fiebres, con intención tanto clasificatoria como necesariamente terapéutica.

La obra está redactada siguiendo el modelo de enseñanza escolástica medieval, en forma de *quaestiones et responsiones* (preguntas y respuestas) seguido todavía en las aulas universitarias de la época. La primera parte estudia la naturaleza y clasificación de las fiebres, en tanto que la segunda se centra en las fiebres: las tercianas, de las cuales describe su sintomatología, así como una opción de tratamiento. En la siguiente expone su opinión sobre el mecanismo de las fiebres tercianas, seguramente la de origen palúdico y las modalidades a observar para su tratamiento. La última se ocupa de los «accidentes» que pueden producirse como secuelas de la fiebre perniciosa y las alternativas terapéuticas que recomienda.

Es un texto adscrito al «galenismo hipocratista moderado», típico de su época. Entre los autores que maneja abundan principalmente las citas de autores peninsulares, sobre todo castellanos y valencianos. Presenta importantes rasgos de influencia, y acaso inspiración, procedentes de los tratados sobre patología febril redactados por Luis Mercado y Pedro Miquel de Heredia. Entre los autores extranjeros mencionados, destaca en especial el iatroquímico y atomista wittenburgués Daniel Sennert. Probablemente su presencia obedezca más al éxito alcanzado en toda Europa por su tratado sobre las fiebres, más que a una adscripción más o menos rotunda de Rapó a los planteamientos intelectuales del paracelsismo y las doctrinas iatroquímicas. Otros tratados sobre la fiebre que alcanzaron un sensible éxito intelectual en la Europa de la época, como los de Giovanni Michaele Savonarola, Giovanni Manardo y Ercole de Saxonia, son asimismo citados en la obra que nos ocupa. Su mención es atribuible a sus respectivas autorías de sobresalientes textos sobre las fiebres pestilentes y su

correspondiente tratamiento. Otro tanto cabe adjudicar a la presencia de Alonso López de Corella autor de la primera monografía castellana de las fiebres conocidas popularmente como «tabardillo».

Los autores de los cuales se citan sus obras pertenecen a un amplio abanico de épocas. Los que mayor número de menciones alcanzan son Galeno e Hipócrates, orientando la obra de Rapó como integrante de la tendencia conocida como galenismo hipocratista. Las obras del primero sobre las fiebres fueron determinantes para los estudios y clasificaciones que guiaron a los médicos posteriores.

Sigue a estos dos una tríada de autores procedentes de las universidades castellanas, principalmente de la alcaína. Prácticamente todos detentaron cargos de médicos de cámara de los distintos monarcas españoles: Luis Mercado, Pedro Miquel de Heredia y Gaspar Caldera de Heredia. La práctica totalidad de éstos, se alinearon con los denominados galenistas hipocratistas tardíos o moderados.

Entre los extranjeros destaca la figura de Daniel Sennert, destacado y temprano iatroquímico wittenburgués. Su presencia obedece a ser autor de una destacada obra sobre las fiebres, de notable aceptación y divulgación en los entornos médicos europeos del XVII, según muestran las no menos de diecisiete ediciones que alcanzó. Junto a él figuran cuatro médicos italianos. Uno, Joanne Michele Savonarola, es plenamente medieval y adscrito al galenismo escolástico arabizado, pero su autoría de una obra sobre las fiebres profusamente reeditada en los siglos renacentistas, constituye un convincente justificante de su presencia. Los otros tres itálicos son: Giovanni Mainardi, Alejandro Massaria y Ercole de Saxonia. Los dos primeros son autores de sobresalientes textos sobre las fiebres pestilentes y el tercero de un escrito sobre el tratamiento de las mismas.

Con menor peso, según demuestra el modesto número de veces en que Rapó los menciona, son el famoso médico judeoportugués Zacuto Lusitano y el navarro Alonso López de Corella cuya temprana monografía sobre el tabardillo lo hace ver como un autor obligado, en una texto dedicado a las fiebres.

Los “valentinos”, como se conocía a los médicos formados en Valencia, tan frecuentes entre los médicos mallorquines de entonces, proporcionan tres nombres al listado pertenecientes a distintas épocas: Luis Collado, Vicente García Salat y Juan Bautista Orivay y Monreal. Todos fueron catedráticos de la Facultad de Medicina de Valencia. Catedrático de la de Barcelona es el gironés Jacint Andreu, presente acaso por haber sido reeditada su obra pocos años antes de que apareciera el texto de Rapó.

Para apoyar sus opiniones o desmentirlas, nuestro autor recurre a una amplia panoplia de autores de todas las épocas. Por supuesto sus páginas rinden tributo de forma preferente los clásicos y obligados autores de los textos del *Corpus Hipocraticum* o Galeno. Menciona, si bien solo en un par de ocasiones, a Avicenna, decidido adversario del galenismo hipocratista profesado por Rapó de forma convencida.

Cronológicamente les sigue el italiano medieval Giovanni Michele Savonarola, cuya obra sobre las fiebres conoció numerosas ediciones que le proporcionaron una difusión extraordinaria en el quinientos. Un singular tratado sobre un tipo concreto de fiebres, explícitamente referido es el de Alonso Lopez de Corella, autor de una temprana monografía sobre las fiebres tifoideas conocidas entonces como «Tabardillo» o *morbo pustulato lenticulari*. Al mismo tiempo recurre a las obras de un grupo de catedráticos alcaínos y de universidades castellanas de esa misma centuria, junto con algunos otros autores italianos de esa época para formar su base principal. A ella se unen autores decisivos del seiscientos sobre el tema de las fiebres, como el ecléctico Sennert, el valenciano Vicente García Salat o los catalanes Jacint Andreu y Joan Bautista Orivay i Monreal.

Conflicto de intereses

El autor declara no tener conflicto de intereses.

Referencias

1. *Apollineum Majoricense bellum contra febres perniciosas. Authore Raphaelae Rapó Sinuensi, medicinae Doctore, et Caroli II Hispaniarum Regis tempore, in Oceani Regali classe insigni ducis officio Catholicorum Armorum exercitatore. Continet tractatum unicum, quaestiones quatuor, Majoricae propriis Authoris sumphibus in Regali Conventu Sancti Dominici cuditum, 1707.* Vendese en el mismo Convento. Y en Barcelona en Casa de Juan Piferrer Mercadel (sic) de Libros en la Plaça del Angel.
2. El conocido «Juramento Hipócratico» comienza invocándole como dios específico y principal de la Medicina, proclamando: *Juro por Apolo, médico, por Higea y por Panacea, y por todos los dioses y diosas...*
3. Pedro Laín Entralgo (1963) *Historia de la medicina moderna y contemporánea*, Barcelona-Madrid-Lisboa-Rio de Janeiro-Montevideo, págs. 32-33.
4. Luis Sánchez Granjel (1978) *La medicina española del siglo XVII*, Salamanca y (1979) *La medicina española del siglo XVIII*, Salamanca.
5. Joaquín M^a Bover i Rosselló (1842) *Memoria de los mallorquines que se han distinguido en la antigua y moderna literatura*, Imprenta-Nacional Á Cargo De Don Juan Guasp y Pascual, Palma págs. 321-323 y (1868) *Biblioteca de Escritores Baleares*, vol. II, Imprenta de Pedro José Gelabert, Palma de Mallorca, pág. 237.
6. Josep M^a Calbet i Camarasa i Jacint Corbella i Corbella (1982) *Diccionari biogràfic de metges catalans*, Tercer volum: R-Z, Fundació Salvador Vives Casajuana, Seminari Pere Mata, Universitat de Barcelona, Barcelona, pág. 22.
7. José M^a López Piñero (2007) *Medicina e Historia Natural en la sociedad española de los siglos XVI y XVII*, Publicacions de la Universitat de València, Universidad de Valencia, pág. 313.
8. María Jesús Sampietro Solanes (2015) *La comunicación científico-médica en Mallorca (1560-1760)*. *Bibliotecas de médicos, boticarios y cirujanos e introducción de medicamentos chymicos*, Tesis doctoral. Director: Francesc Bujosa Homar. Universitat de les Illes Balears. Palma, pág. 507.
9. Rosa María Moreno Rodríguez (1985-86) «Acerca de la cualidad del calor innato en las fiebres, según Galeno», *Dynamis. Acta Hispanica ad Medicinae Scientiarumque Historiam Illustrandam*, Vol. 5-6, págs. 11-30: 11-12.
10. Luís García Ballester (1972) *Galeno. En la sociedad y en la ciencia de su tiempo (c. 130-c. 200 d. de C.)*, Madrid, págs. 259-264.
11. Fiebre elevada, acompañada de síntomas generales intensos y ausencia de síntomas locales. Debe su nombre a que tan solo acostumbraba a durar un día y acababa por crisis.
12. La Fiebre Héctica, llamada también Colicuativa o Lenta estaba caracterizada por una temperatura alta y comúnmente continua, con exacerbaciones nocturnas, acompañada de enflaquecimiento progresivo, debilidad y alteración de la frecuencia del pulso, calor en la piel y sobre todo en las palmas de las manos y plantas de los pies, sudores y diarrea. Era la que ahora se identifica como característica de la tuberculosis pulmonar y a la que seguramente correspondía. Una opinión posterior sobre este tipo de fiebre la expone el *Suplemento al Diccionario de Medicina y Cirugía* del profesor D. Antonio Ballano, por los Doctores D. Manuel Hurtado de Mendoza y por D. Celedonio Martínez Caballero (Madrid, 1821). En dicha obra la voz sobre la «Fiebre Colicuativa» es considerada como impropia para indicar una patología que asociaba fiebre y marasmo.
13. La fiebre pútrida es la que Pinel identificará como fiebre adinámica y Brown como fiebre asténica. Su principal característica clínica es que cursa con notable postración muscular.
14. Se calificaba como Fiebre intermitente toda calentura que presentase los síntomas comunes a todas las demás calenturas, con la diferencia de que estos síntomas cesan y se reproducen á intervalos más o menos largos.
15. Gerrit Bos y Y. Tzvi Langemann (2015) *The Alexandrian Summaries of Galen's On Critical Days. Editions and Translations of the Two Versions of the Jawami?*, with an Introduction and Notes, Islamic philosophy, Theology and science. Text and studies, 92. E. J. Brill. Leiden.
16. Juan Riera Palmero y Guadalupe Albi Romero (2004) «El avicenisismo renacentista en la Universidad de Salamanca», *Lull* vol. 27, págs. 700-745: 708.
17. Rosa María Moreno Rodríguez (1985-86) págs. 20-21. In-Sok Yeo (2004) *La théorie des fièvres chez Galien: introduction, traduction et commentaire du traité sur "La différence des fièvres"*, Thèse de doctorat en Histoire de la Médecine. Sous la direction de Amelle Debru. Soutenue en 2004 à Paris 7.
18. Luis García Ballester (2001) *La búsqueda de salud. Sanadores en la España medieval*, Barcelona, pág. 446.
19. Bynum, W. F., & Nutton, V. (1981) «Theories of fever from Antiquity to the enlightenment: Introduction». *Medical History. Supplement*, (1), VII-IX. Hamlin Christopher (2015) *More Than Hot: A Short History of Fever* (Más que caliente: una breve historia de la fiebre), Baltimore, MD: Johns Hopkins University Press.
20. A. Gomez Pereira (1558) *Novae veraeque Medicinae, experimentis et evidentibus rationibus comprobatae, prima pars/per Gometium Pereiram... nunc primum in lucem edita*, Methymhae Dvelli: Franciscus a Canto.
21. Pedro Laín Entralgo (1963) *Historia de la medicina moderna y contemporánea*, Barcelona-Madrid-Lisboa-Rio de Janeiro-Montevideo, págs. 32-33.
22. Fernando de Mena (Socuéllamos (Ciudad Real), c. 1510 – Madrid, c. 1568) Licenciado en Medicina (1543) y doctor (1544) por Alcalá, donde fue catedrático de Vísperas desde 1545 a 1553, momento en que sucedió a Diego de León en la Cátedra de Prima. Su carrera culminó con el nombramiento de médico de Cámara de Felipe II en 1560. Adscrito al más riguroso galenismo hipocratista, fue ante todo un convencido seguidor de Galeno, cuyas obras sobre el pulso, orina, flebotomía, purgas y fiebre comentó. <https://dbe.rah.es/biografias/19604/fernando-de-mena>
23. *Methodus februm omnium, et earum symptomatum curatoria, Antuerpiae, ex officina Christophori Plantini, 1568.*
24. Pedro Mercado (p. s. XVI – ?, f. s. XVI) era natural de Granada, probablemente estudió en su Universidad y regentando una de las cátedras, <https://dbe.rah.es/biografias/19632/pedro-mercado>
25. *De februm differentiis, earumque causis, signis, medela: tam in universali quam in particulari ex antiquorum et iuniorum: tum graecorum tum Arabum auctoritate [...] eiusdem auctoris scholii*, Granatam, in aedibus Antonii Nebrissensis, 1583. Reeditado en: Madrid, J. Vázquez de Mármol, 1582 y Granada, apud viudam Ioannis Galindi, 1592.
26. Las que aparecen en el llamado «marasmo», identificable como una situación de deterioro físico y psíquico extremo del sujeto, propio de fases terminales de enfermedades prolongadas. Una de las que lo producía entonces con más frecuencia, era la última etapa de la sífilis (PGP).

27. Dedicó al problema de las fiebres su: *Libellus de essentia, causis, signis et curatione febris malignae, in qua maculae rubentes similes morsibus pulicum per cutem erumpunt*, Valladolid, D. Fernández de Córdoba, 1574. *De februm essentia, differetiis, causis, dignotione & curatione Libri sex Quorum primus essentiam, Secundus differentias februi expedit. Tertius causas. Quartus febres ephemeram exsequitur, & curare docet. Quintus hecticas. Sextus vero pulidas omnes. Quibus accessit de februi pestilenti ac de maligna & contagiosa. Liber septimus*, Vallisoleti, apud haeredes Bernardini á Sancto Dominico, 1586. Otra edición en Basilea con el título de la edición de 1574: *De essentia cavsis signis [...], pero con el contenido del texto de 1586. Libellus de essentia, causis, signis & curatione febris maligna, in qua maculae rubentes similes morsibus pulicum per cutem erumpunt. Cui accessit consilium continens summa totius praedictionis & curationis in eodem affectu*, Basilea, apud conradum Waldkirch, 1594.
28. Luis Mercado se formó en Valladolid, donde se doctoró en 1560 y obtuvo la Cátedra de Prima de Medicina en 1572. jubilandose, tras veinte años de docencia como catedrático en esa facultad de medicina. Médico de cámara de Felipe II y Protomédico general de los Reinos de España, continuó ejerciendo esos cargos durante los primeros años del reinado de Felipe III. <https://dbe.rah.es/biografias/13669/luis-de-mercado>
29. Alvar Martínez Vidal y José Pardo Tomás (2003) «Un siglo de controversias: la medicina española de los Novatores a la Ilustración», en: J. L. Barona, J. Moscoso, J. Pimentel, eds.: *La ilustración y las ciencias: para una historia de la objetividad*, Universidad de Valencia, Valencia, págs. 107-136: 110-111.
30. Por fiebre intermitente se entendía toda calentura que presentase los síntomas comunes a todas las demás, aunque con la diferencia de que estos síntomas cesaban ocasionalmente, para reproducirse a intervalos más o menos largos.
31. Las fiebres tercianas y cuartanas deben su nombre a que sus accesos se producían periódica y respectivamente cada tres o cuatro días, con intervalos de uno o dos días de apirexia completa. El ejemplo más típico son las fiebres llamadas palúdicas por ser consideradas típicas del paludismo, causado por el *plasmodium malariae*.
32. Jerónimo Rubio (post. 1638) *Alegación, hecha en favor de la verdad, de los sucessos de enfermedades que hubo en la Villa de Epila, el año 1638*, siendo su Apotecario Bernardo de Alarcón..., Zaragoza, s. i..
33. Damián de Mayorga y Guzmán (1674) *Manifiesto sobre el conocimiento individual de la calentura maligna*, Zaragoza.
34. Juan Bernés (1674) *Papel... en que responde a un manifiesto que escribió el doctor Damián de Mayorga y Guzmán... sobre el conocimiento individual de la calentura maligna*, Madrid, por Andrés García.
35. Pedro García Carrero (1611) *Disputationes medicae super fen primam libri primi Auicennae etiam philosophis valde utiles / opus doctoris Petri Garcia Carrero... ; cum indice completissimo rerum memorabilium*, Compluti: ex officina Ioannis Gratiani, apud Viduam, 1611.
36. Accidente: síntoma indicador de la alteración de la sustancia corporal considerada como consecuencia y manifestación causada por la enfermedad.
37. Justo Hernández (2002) «La sangría en el *Liber de Arte Medendi* (1564) de Cristóbal de Vega (1510-1573)», *Asclepio*, vol. LIV-2, 2002, págs. 231-252: 244, nota 41: C. de Vega (1564) pág. 327.
38. Las fiebres llamadas especiales o complicadas eran las que sin presentar en sus accesos síntoma alguno alarmante o peligroso, se calificaban de *simples*. En cambio, cuando de forma concomitante presentaban un estado adinámico, atáxico, soporoso, delirante o cefalálgico, se apellidaban de acuerdo con el síntoma dominante. Es decir, las fiebres intermitentes, perniciosas, adinámicas, atáxicas, soporosas, cefalálgicas, sincopales, delirantes, pleuríticas, etc., respondían a procesos patológicos de curso febril con sintomatología predominante de adinamia, ataxia, sopor, cefalalgia, síncope, delirio, pleuresia etc..
39. La fiebre singultosa ó hiposa es una calentura intensa, entre cuyos síntomas sobresale o predomina el hipo.
40. Fiebre vertiginosa era la que se acompañaba de intensos vértigos e inestabilidad ambulatoria.
41. Por fiebre ardiente se entendía una hipertermia asociada a una alteración del sistema vascular sanguíneo, que cursaba con aceleración del pulso (taquicardia).
42. La fiebre sanguínea era sinónimo de la fiebre inflamatoria, llamada posteriormente fiebre angioténica. por Pinel. Se identificaba con la alteración del sistema vascular sanguíneo.
43. Fiebre sincopal: variedad de la fiebre intermitente perniciosa, durante cada acceso de la cual el enfermo experimenta síncope más o menos frecuentes y completos.
44. La fiebre epiala es sinónimo de fiebre álgida. En el galénico *De inaequalis intemperies* es considerada un exceso simultáneo de los humores pituitoso y bilioso y se expanden a todas las partes orgánicas sensibles. Su clínica cursa con una elevación de la temperatura del sujeto a veces continua y las más veces intermitente, acompañada de un frío (escalofríos) excesivo y continuo.
45. La fiebre llamada lipiria ó lipírica era una variedad en la cual el enfermo presentaba sensación de fuego interior y frialdad periférica en extremidades.
46. Jean Fenel (Clermont-en-Beauvoisis, 1497. París, 1558) llamado "El Galeno moderno" por su importante redacción de escritos médicos. Decididamente adscrito al galenismo, su vertiente práctica y aguda observación le permitieron realizar una síntesis de la medicina tradicional de su época. Característico hombre del mejor renacimiento humanista, hizo recuperar el estudio de las fuentes clásicas de la antigua medicina griega. Fue médico de corte de Enrique II de Francia.
47. Luis Sánchez Granjel (1978) «Fiebres, epidemias y contagios», en: *La medicina española del siglo XVII, Historia General de la Medicina Española*, Universidad de Salamanca, págs.170-175: 172.
48. Pedro Miguel de Heredia (1665) *Operum medicinalium tomus primus: in quo iuxta Hippocratis, Galeni & Auicennae mentem: de febribus...* / D. Petri Michaelis de Heredia... Nunc primum cum indicibus necessariis in lucem prodit, Lugduni: Sumptib. Philippi Borde, Laurentii Anaud, Petri Borde, et Guill Barbier. Reeditado en (1689) bajo el título de: *Cl. Viri D. Petri Michaelis de Heredia... Opus medicinalium tomus primus: in quo juxta Hippocratis, Galeni et Auicennae mentem perfecté & absolute tractatur de febribus*. Editio altera perquam accurate recognita ac emendata curá & diligentiá D. Petri Barra de Astorga, Lugduni: sumptib. Petri Borde, Ioan & Petri Anaud y en (1690) con el título de: *Opera medica: in quatuor tomos divisa: tomus primus in quo iuxta Hippocratis, Galeni et Avicennae mentem perfecte & absolute tractatur de febribus*, Editio ultima perquam accurate recognita ac emendata cura & diligentia Petri Barea Astorga, Antuerpiae: apud Ioannem Baptista Verdussen.
49. Recibe el nombre de fiebre intermitente la que cursa con intervalos de días apiréticos irregularmente distribuidos y más o menos numerosos.
50. Se consideraba fiebre perniciosa a toda calentura intermitente ó remitente, cuyos accesos en las primeras o segundas exacerbaciones presentasen síntomas alarmantes y una evolución insidiosa, considerada de mal pronóstico. A menudo se calificaban así las de origen palúdico, que cursaran con síntomas graves, en accesos de evolución rápida y elevada, estimados susceptibles de causar la muerte en los primeros episodios febriles.

51. Francisco Henríquez de Villacorta (1670) *Francisci Henríquez de Villacorta ..., Laureae doctoralis medicae complutensis: tomus primus quo continentur summe necessaria pro Laurea Doctorali Academiae Complutensis consequenda, eo certamine quod vocatur*. Lugduni: sumptibus Laurentii Anisson, tres vols.. La reedición de 1688 se tituló: *Francisci Henríquez de Villacorta..., Laureae doctoralis medicae complutensis tomus primus: quo continentur summe necessaria pro Laurea doctorali*, Editio nova cui accessit consultatio medica, Lugduni: apud Anissonios, Posuel & Rigaud.

52. El tercero de sus volúmenes de la reedición de 1680 lleva por título: *Tomus tertius. Quo continentur: Tractatus de Methodo medendi. De Alimentorum facultatibus. De Alimentorum facultatibus in particulare. De victus ratione in morbis acutis. De Balneorum natura et usu. De prognosticis et de Arte praenoscendi. De Crisibus et diebus decretoriis. De facultatibus. De venenis. De Locis affectis Resolutiones Theoricae. Disputatio Apologetica de sanguinis missione in talo*. Pro eo certamine quod vocatur Alphonsina. Cum indicibus necessariis. Lugduni, Sumptibus Anissoniorum et Joan Posuel.

53. Matías de Llera (1666) *Manus medica dextera quinque digitos continens: quorum primus disputationem in duos Galeni libros de febrium differentis: secundus... de curandi ratione per sanguinis missionem: tertius controversias de purgatione...: quartus tractatum de crisibus et diebus decretoriis : quintus... consultandi rationem proponit, excutit ac dirimit / authore Doctore Mathia de Llera, Caesar-Augustae: apud Ioannem de Ybar y (1674) Clavis totius medicinae: dentibus octo acutissimis fabrefacta...per octo videlicet libros Methodi Medendi Galeni a septimo duntaxat usque ad decimum-quartum: accedit denuo manus medica dextera*, Lugduni, sumptibus elaudii Bourgeat, 1674.
http://www.encyclopedia-aragonesa.com/voz.asp?voz_id=8084

54. La calentura ardiente exquisita, llamada también causón, es una fiebre violenta, continua, causada por cólera podrida en el interior de las venas. Los autores árabes la atribuían a la flema salada.

55. Juan Gallego de la Serna (1634) *Ioannis Gallego de la Serna... Opera physica, medica, ethica:quinque tractatibus comprehensa*. Lugduni: sumptibus Iacobi & Petri Prost fr.

56. Estudió Artes en Alcalá (1606) y Medicina no se sabe bien dónde. Obtuvo los grados de licenciado y doctor en dicha facultad en Santa Catalina de Osma (1612). Médico de Arévalo hasta 1629, en 1630 se incorporó a la Universidad de Valladolid, renovando en ella los títulos de licenciado (1632) y doctor (1634), al tiempo que se integraba en la docencia. Catedrático de Método (1630), de Vísperas (1634) y de Prima de Hipócrates (1646), regentó esta última hasta su nombramiento como médico de la Cámara de Felipe IV (1650). La fecha de su muerte es incierta.

57. Cipriano de Maroja Latorre (1641) *Tractatus de febrium natura communi et singulari, earundemque causis, signi ac curatione. In quo plurima difficillima conspicua, et scitu digna traduntur ad Philosophiam et Medicinam attentiam. Cui accessit Brevis tractatus de Morbi Gallici natura, et curatione. Item et celebris Quaestio e Philosophiae visceribus extracta, De partium materialium diversitate in mixtis*, Vallisoleti, apud Hieronymum Murillo, Typographum Regium. et Universitatis.

58. Fiebras tercianas exquisitas y dobles son fiebres intermitentes hechas por cólera sola que se pudre en las venas. No eran consideradas una variedad peligrosa por Hipócrates y Galeno. Sus dos variedades son la única y la doble. La única es aquella en que el acceso se produce de tercer a tercer día. La doble se presenta dos veces cada tercer día o una vez cada día. Pueden causarla aires calientes, alimentos mordaces, cómo las especies pimienta y mostaza o trabajos excesivos durante el verano, ya que engendran cólera flava. Esta denominación del «humor colérico», «bilis amarilla» o «cólera» se denominaba así por tener color entre amarillo y rojo, semejante al de la miel o al del oro. Se consideraba a este humor como correspondiente al elemento «fuego» y con las características de ser caliente y seca. Le correspondían los tres meses estivales.

59. Iuan de la Torre y Balcarçel (1688) *Espejo de la philosophia y compendio de toda la medicina theorica y practica / por....*, Impresso en Amberes: en la Imprenta Plantiniana de Baltasar Moreto. Se reeditará en (1705) con el mismo título y el *Añadido y enmendado en esta impression el Tratado de Morbo Galico*. En Madrid: Por Juan Garcia Infançon... : A costa de Francisco Sazedon.

60. Gaspar Bravo de Sobremonte Ramírez (1649) *Doctor Gaspar Bravo Ramirez de Sobremonte Sanctae Inquisitionis familiaris et medicus primarius ... edit tomum primum Resolutionum medicarum circa vniuersam totius physiologiae doctrinam*, Vallis-Oleti: ex typographia Antonij Vazquez à Sparça. Luís Sánchez Granjel (1978) pág. 172.

61. Expuestas por Johannes Bapista van Helmont (Bruselas, 1578-1644) defensor de Paracelso y las doctrinas iatroquímicas. Autor de: *Ortus medicinae, Id est, initia ptyysicae inaudita. Progresses medicinae novus, in morborum ultionem, advitam longam*, Amsterdam: Ludovicus Elsevir, (1648) publicada póstumamente por su hijo. Alcanzó notable éxito en los siglos XVII y XVIII, de modo que en 1707 se había reimpresso 12 veces y traducido a cinco idiomas. Más que un tratado de medicina es todo un nuevo sistema filosófico y religioso, con una propuesta para reformar de forma completa la filosofía natural.

62. Gaspar Bravo de Sobremonte Ramírez, (1674) *Doctoris Medici D. Gasp. Bravo de Sobremonte Ramirez ... Operum Medicinalium tomus tertius: tres Tractatus complectens In quorum primo de Theoria & praxi febrium intermittientium lethaliu agitur. Secundus disputationem unicam continet de crisibus, diebus decretoriis, de illorum causis; & de lotio ac sedimentis. Tertius tandem promptuaria varia miscellanea, multis neccesaria, & utilia exhibet, Nunc primum in lucem prodit*, Lugduni: Sumptibus Laurenti Anaud; & Petri Borde.

63. El diagnóstico de fiebre pestilencial era utilizado como eufemismo para no utilizar el nombre de peste que a menudo encubría. Esta conducta de evitación es denominada *peur du mot* (miedo al nombre) por los historiadores franceses y fue bastante común en la época de las grandes epidemias de peste. Era representativa de una actitud derivada del absoluto terror que causaba la simple mención del entonces considerado terrible nombre de esa epidemia. En esos momentos seguía siendo considerada como en tiempos clásicos o medievales resultante de un envenenamiento atmosférico. Su curso iba asociado a inflamaciones extensas, tanto cutáneas como glandulares. Más adelante Pinel la etiquetará como fiebre adeno-nerviosa.

64. Luís Sánchez Granjel (1978) pág. 173.

65. Diego Rodrigo Guerrero (1606) *Disputatio de natura febris...*, Hispali, Apud Illefonsum Rodericum Gamarra.

66. Benito Matamoros Vázquez (1622) *Selectarum medicinae disputationum : tomus I in quo praeter ea quae de febrium theoria, coctione & putredine & alijs ex professo disputantur ; plura etiam alia difficillima ad vtranque medicinae partem spectantia obiter disquiruntur / authore Benedicto Matamoros Vazquez Gallego...*; cum indice rerum praecipuarum locupletissimo; ad serenissimum infantem Ferdinandum ab Austria, magni Philippi III, Vrsae: apud Ioannem Serrano de Vargas & Vreña, Vniuersitatis typographum.

67. Jean Fernel (Clermont-en-Beauvoisis, 1497. París, 1558) llamado "El Galeno moderno" por su importante redacción de escritos médicos. Decididamente adscrito al galenismo, su vertiente práctica y aguda observación le permitieron realizar una síntesis de la medicina tradicional de su época. Característico hombre del mejor renacimiento humanista, hizo recuperar el estudio de las fuentes clásicas de la antigua medicina griega. Fue médico de corte de Enrique II de Francia.

68. Francisco Vallés de Covarrubias (Covarrubias (Burgos) 1524 – Burgos, 1592.) llamado «El divino Vallés» y «El Galeno español». Su formación y actividad docente se desarrolló en la Universidad de Alcalá, donde tras licenciarse en Artes (1547) y Medicina (1553) y doctorarse (1554), ocupó la Cátedra de Prima de Medicina desde

- 1557 hasta 1572. En esta última fecha pasó a ser médico de cámara de Felipe II, quien lo nombró "Protomédico general de todos los Reinos y Señoríos de Castilla". Autor de un breve tratado semiológico sobre la orina, el pulso y la fiebre, titulado *Commentarii de urinis, pulsibus 6 febribus longe eruditissimi*, Compluti, In officina Ioannis de Villanova & Petri Robles, 1565 y un comentario al galénico *Methodus medendi* [...], Madriti, Apud Querinum Gerardum expensis Blasii a Robles, 1588. <https://dbe.rah.es/biografias/4920/francisco-valles-de-covarrubias>
69. Cristóbal de Vega (Alcalá de Henares (Madrid), 1510 – ?, 1573) Catedrático de la Facultad de Medicina de la Universidad de Alcalá y médico de cámara del príncipe Carlos. A comienzos de 1548, se encargó durante un período breve de la cátedra de Avicena en la Facultad de Medicina de la Universidad de Salamanca. Autor de diversas obras de medicina entre las que por lo que al tema de las fiebres se refiere, cabe destacar su *Comentaria in librum Galeni de differentia febrium*, Alcalá, Juan Mey, 1554. <https://dbe.rah.es/biografias/20116/cristobal-de-vega>
70. Pedro Camañes (1625) *In duos libros artis curativae Galeni ad Glaucanem commentaria; in quibus omnes fere materiae, quae ad praxin medicam et chirurgicam occurrunt, dilucide explanantur...* Opus nunc primum in lucem editum, Valentiae, Michael Sorolla.
71. José Francisco Rossell (1627) *In sex libros Galeni de differentiis et causis febrium. Accesserunt epistolae duae: una ad Andream Laurentium in Monspelicense academia, altera ad Joannem de Carvajal in liceo Hispalensi, publicos medicine professores, Barcelona, Sebastián Mathevat.*
72. Juan Bautista Navarro (1693) *Comentarii ad Libros Galeni de Differentiis Febrium, de Pulsibus ad Tyrones, et Spurium de urinis... In hac ultima editione addita es Anacephalaeosis Librorum Galeni de crisiibus*, Valentiae, Vicentius Cabrera.
73. Sebastian de Soto (1638) *Exercitationes medicae, de curandis febrium differentiis*, Matriti, Ex Officina Joannis Sancii Typographi.
74. Vicente García Salat (1652) *Utilissima disputatio de dignotione et curatione febrium*. Auctore Vincentio Garcia, Valentiae: Ex typographia Fuster, juxta Templum S. Martini. Expensis Joannis Laurentii Cabrera. Reeditada en Chiva (1656).
75. Juan Lázaro Gutiérrez (1668) *Febriologiae Lectiones Pincianae. Theoripracticum Opus Acroamaticum ad Hippocratis mentem, ac Galeni sensum; ad Avicennae iudicium nunc primum prodit*, Lugduni, Sumptibus Laurentii Anisson.
76. Luís Sánchez Granjel (1978) pág. 174.
77. Francisco Duarte Méndez (1648) *Questión medica, si en la cura de las enfermedades, y principalmente de las calenturas podridas, es conveniente purgar los enfermos en algunos casos antes que se sangre*, Madrid, por Domingo García y Morras.
78. Juan Bautista Orivay i Montreal (1679) *Theatro de la verdad y claro manifesto del conocimiento de las enfermedades de la ciudad de Orihuela del año 1678*, Zaragoza.
79. Pedro Antón Barba (Astudillo (Palencia, s.m.s. XVI - ?, s.m.s. XVII). Formado en la Facultad de Medicina de Valladolid. Obtuvo el grado de Bachiller (21 de abril de 1595) la licencia de ejercicio por el Protomedicato (10 de marzo de 1598), la licenciatura (28 de mayo de 1615) y el doctorado (11 de octubre de 1620). Médico de Cámara de Felipe IV desde 1663. <https://dbe.rah.es/biografias/7754/pedro-anton-barba>
80. Pedro Barba (16420) *Vera Praxis de curatione tertianae stabilitur, falsa impugnatur: liberantur Hispani Medici a calumniis*, Bruselas, Typis Mommartianis.
81. Salvador Leonardo de Flores (1698) *Desempeño a el metodo racional, en la curacion de las calenturas tercianas, que llaman notas*, Sevilla, por Juan Francisco de Blas.
82. José Luis Barrio Moya (2006) «Don Pedro Barba, médico valentino del rey Felipe IV. Aportación documental», Publicaciones de la Institución Tello Téllez de Meneses, ISSN 0210-7317, nº. 77, págs. 385-406.
83. Cristóbal Tristán de Acuña (1642) *Antithesim ad repetitionem de tertiana pro-medicina iberorum*, Lovainii.
84. Diego Salado Garzes (1679) *Estaciones médicas, en las quales para mayor confirmacion de la doctrina del Apologetico Discurso, con que se prueba que los Polvos de Quarango se deben usar por Febri-fugio de Tercianas, y Quartanas*. Sevilla: Tomás López de Haro.
85. Noble David Cook - José Hernández Palomo (1992) «Epidemias en Triana (Sevilla, 1660-1865)», *Annali della Facolta de Economia e Commercio della Universita Di Bari*, vol. XXXI, págs. 53-81: 61, señala tan solo una epidemia de fiebres tercianas en Sevilla (1785-1786) y una de fiebres catarrales durante 1689-1690.
86. Alonso Lopez Corneio [1699?] *Galeno ilustrado, Auicena explicado, y doctores seuillanos defendidos: refutase la nueua con la antigua medicina...: dalo a la luz publica con el motiuo de vn tratado que salio con el nombre de Desempeño al methodo razional... / Alonso Lopez Corneio ...*, En Sevilla :, por luan de la Puerta.
87. Formado en la Universidad de Sevilla, donde más adelante fue catedrático de Prima. Ya retirado de la docencia defendió el galenismo tradicional frente a los novatores de la Regia Sociedad de Medicina de Sevilla. J. Esteva de Sagrera (1978) «Una polémica sobre la eficacia de los medicamentos espágricos, en el "Galeno ilustrado...", de Alonso López Cornejo» *Bol Soc Esp Hist Farm.*, Mar. 113, págs. 21-30.
88. *Antipología médica á el libro apologetico aunque con nombre del doctor D. Alonso López Cornejo, etc., que salió á luz con título de Galeno ilustrado, contra el tratado: Desempeño á el método racional en la cura de las tercianas notas [...]*, Madrid, Diego Martínez Abad, 1705
89. Luís Sánchez Granjel (1978) pág. 175.
90. Cipriano de Maroja Latorre (1641) *Tractatus de febrium natura communi et singulari...*, op. cit.
91. Juan Lázaro Gutiérrez (1688) *Febriologiae Lectiones Pincianae*, op. cit.
92. Tomás Longás (Borja (Zaragoza), c. 1625 – Tarazona (Zaragoza), 1690) Formado en Artes y Filosofía en la universidad de Huesca y luego en Medicina en la de Valencia. Ejerció la medicina en Borja y más tarde en Tarazona, donde fue médico titular del Cabildo de la catedral. No debe ser confundido con su hijo llamado Tomás Longás y Pascual, que fue titular de la cátedra de Anatomía en la Universidad de Valencia desde 1698 y uno de los defensores de la renovación científica en dicho centro en las primeras décadas del siglo XVIII. Redactó: *Enchiridion novae et antiquae Medicinae dogmaticae, pro curatione febris malignae. continens historiam febris Excellentissimi Dominici Ducis de Villa-Hermosa et tractatus valde utiles pro curatione in universum, Caesar Augustae, apud Paschasium Bueno*, 1698. <https://dbe.rah.es/biografias/19556/tomas-longas>
93. Juan Nieto de Valcárcel (1681) *Manual y pronta resolución para precaverse y curarse de la peste, o cuestion única de la fiebre pestilente y maligna que llaman punticular o tabardillo*, Madrid.
94. Juan Nieto de Valcárcel (1685) *Disputa epidemica. Teatro racional, donde desnuda la verdad se presenta al examen de los Ingenios. Thesis en que se ventila el uso de los Alexifármacos Sudoríficos en el principio de las malignas del año de 84...*, Valencia, s. i., 1685.

95. Felix Osona (1698) *Tractatus de febre maligna Vicensi famosa ad alios etiam affectus accommodus, a doctore Felice Osona ... : euidem famosa merito inscribitur haec nostra febris, siquidem clamosa circa illam suscitata oppositio per totum resonuit principatum, etiam quia dextera eius curatio, tamquam fama, leges à medicinae principibus stabilitas promulgat, ne in illa, neque in alijs praeter naturam affectibus talis artis cultores delinquant, lege & hoc invenies & procellosis nubibus discussis, veritatem clariùs orientem*, Barcinone: ex typographia Raphaelis Figveró (1699) *Anathomes novi tractatus de febre maligna Vicensi famosa...* Barcinone, apud Figueró.
96. Felix Osona (1699) *Dilucidatio veritatis solidioris circa sanguinis missionem in privatis febribus malignis*, Barcinone.
97. Era doctor en Filosofía y en Medicina. Impugnó el texto de Osona en: Ignasi Moreta (1699) *Mercurius compitalitius verioris medicinae viam commonstrans philotheoro medico peregrino apud rationale tribunal ducto* / a Ignatio Moreta, Barcin[onae] apud Figueró.
98. Marcia Homs (1699) *Anathomes novi tractatus de febre maligna vicensi famosa / a doctore Felice osona in lucem editi; Dilucidatio veritatis solidioris circa sanguinis missionem in praefatis febrivus malignis, non frivolis et chimericis fundamentis stabilita sed Herculis hyppocraticis et galenicis columnis fundata / a doctore Martiano Homs*, Barcin[onae] apud Figueró.
99. Felix Osona (1700) *Appendix tractatus de febre maligna Vicensi famosa...*, Gerundae, apud Hyeronimum Palol.
100. Bernat Bestard (1992) *La Facultad de Medicina de la Real y Pontificia universidad Literaria del Reino de Mallorca. Primer análisis crítico histórico*. Tesis Doctoral. Universidad de Barcelona,
101. Bartomeu Mulet, Ramón Rosselló Vaquer, Josep. M. Salom, (2001) *Ja està fet Sineu, segle XVII*, Ajuntament de Sineu, Sineu, pàg. 103.
102. ARM, P-829, fol. 280 y ss.
103. ARM, Prot. Not. Antoni Estela, E-137, fol. 358 y ss.
104. María Jesús Sampietro Solanes (2015) pág. 78.
105. Bartomeu Mulet, Ramón Rosselló Josep M. Salom (2001) pág. 331. Su testamento donde figura el inventario de sus bienes se encuentra en: A. R. M., Prot. Not. Antoni Estela, E-157, f. 41 v.
106. Bartomeu Mulet, Ramón Rosselló, Josep M. Salom (2001) pág. 602.
107. Rafael Rapó (1680) «Diálogo per celebrar les festes del Rey D. Carlos segon ab Done Maria Lluïssa de Borbon, fille del Duque de Orleáns, compost per lo Doctor Raphel Rapó, metje, per celebrar las festas en la vila de Sineu, fet als 22 de abril de 1680», en: *Manuscritos autógrafos sobre Mallorca*, fols. 18-22, volumen manuscrito de la Biblioteca Gabriel Llabrés de Palma de Mallorca. S. Reus i Belmar (1994) «Un col·loqui del metge Rafel Rapó (1645-1710)», *Randa/Miscel·lània Josep Maria Llompart*, I, 35, págs. 17-43; Albert Rossich (2001) «El teatro barroco (siglo XVII)», en Albert Rossich, (coord.) *El teatro català dels orígens al segle XVIII, Actes del II Col·loqui Problemes i Mètodes de Literatura Catalana Antiga: "Teatre català antic"*, Girona, 6 al 9 de juliol 1998, Kassel, Edition Reichenberger, págs. 57-79.
108. Raphael Rapo (1707) s. p.
109. A esta cuestión había dedicado en años anteriores un tratado el médico mallorquín Pere Onofre Esteve, titulado *Tratado breve y Antorcha luminosa que con sus luces bellas nacidas de los mayores autores y de la experiencia se descubren atomos los mas retirados a las tinieblas de la practica donde se ven claramente los muchos asieros y prodigiosos efectos de las sangrias del tubillo minorativas y dieta*, Pedro Frau, Impresor de la Inquisición, Ciutat de Mallorca, 1681. Cf. A. Contreras Mas, (2006) «La polèmica sobre la sagnia a Mallorca en el segle XVII: Pere Onofre Estevan (1681)», *Actes de la VIII Trobada d'Història de la Ciència i de la Tècnica: Mallorca-Barcelona, Societat Catalana d'Història de la Ciència i de la Tècnica* (2006), 163-178.
110. Sinónimo corriente entonces de las fiebres Colicuativa y Héctica.
111. «Fiebres nothas» son fiebres intermitentes causadas por cólera flava y flema o pituita, aunque en menor cantidad de la segunda. Su causa habitual son alimentos susceptibles de engendrar exceso de cólera y flema, como ajos, cebollas, mostazas, carne de puerco, vino nuevo y otros semejantes.
112. La fiebre calificada de maligna, llamada también nerviosa cursaba con gastroenteritis asociada a síntomas nerviosos. Corresponde a la que Pinel denominó posteriormente Fiebre atáxica.
113. Las fiebres tercianas eran las más frecuentes de la época. Habitualmente se las identifica con las fiebres palúdicas características del paludismo, pero podían presentarse también en casos de otras patologías infecciosas.
114. La «fiebre sinoca», escrito a veces synocha, se trata de lo que posteriormente se conocerá como «calentura inflamatoria». Corresponde a una alteración del sistema vascular sanguíneo debida sobre todo a causas locales.
115. La fiebre sinoca serosa era originada por tener su supuesto foco lesivo en un tejido seroso, presentándose acompañada de enflaquecimiento y disminución de fuerzas.
116. La fiebre terciana en su variedad pernicioso correspondía a una posible infección por paludismo, especialmente cuando entraba en las fases finales de la evolución de esa patología.
117. *Apollineum Majoricense* (1707) pàg. 322, col. 2.
118. La fiebre llamada pernicioso era toda calentura intermitente o remitente, cuyos accesos en las primeras exacerbaciones o en las segundas, ofrecían síntomas alarmantes y una evolución insidiosa con riesgo de poder acabar funestamente. La fiebre intermitente era la calentura que presentase los síntomas comunes a todas las demás, pero con la diferencia de que estos síntomas remitían por completo y se reproducían a intervalos más o menos largos. Se la denominó también fiebre crónica. Por fiebre remitente se entendía toda calentura continua que presenta en su curso o marcha paroxismos o exacerbaciones que principian con frío á intervalos más o menos iguales.
119. Es una obra de Hipócrates de carácter dietético, comentada por Galeno. Fue estudiada por numerosos autores de prestigio en siglos siguientes, que como buen número de estos textos conoció un importante número de ediciones.
120. *De differentiis febrium* (*Sobre las diferencias de las fiebres*).
121. *De marcure* (*De marasmo; Sobre la consunción*) es un escrito de carácter principalmente terapéutico traducido por Niccolo da Reggio y por Pietro de Abano, de manera independiente. Cf. Anna Maria Urso (2015) «Pietro d'Abano e Niccolò da Reggio traduttori di Galeno: il caso del "De Marcure", Galenos 8, págs. 53-77. <https://www.jstor.org/stable/26930801>. Una de sus ediciones llevó el título siguiente: *Galeri De marcure libellus*, Hermanno Cruseiro campensi interprete, Parisiis: vaeneunt apud Christianum Wechielum, [ca 1533]
122. *Methodus medendi* (*Sobre el método terapéutico*). No debe ser confundido con el también galénico *Ad Glauconem de medendi método* (*Sobre la terapéutica a Glaucón*).
123. *Libellus de essentia, causis, signis et curatione febris malignae, in qua maculae rubentes similes morsibus pulicum per cutem erumpunt*, Valladolid, D. Fernández de Córdoba, 1574.

124. *Viri Petri Michaelis de Heredia... Operum Medicinalium Tomus Primus / Secundus / Tertius / Quartus*, Lyon 1655. Reediciones en 1673, 1688-89 i 1690.
125. José María López Piñero y Francisco Calero (1992) «*De Pulvere Febrifugo Occidentalis Indiae*» (1663), de Gaspar Caldera de Heredia y la introducción de la Quina en Europa, Instituto de Estudios Documentales e Históricos sobre la Ciencia, Universidad de Valencia-C.S.I.C. Valencia, págs. 12-13.
126. *De febribus libri IV ...*, Wittebergae: Apud Zachariam Schurerum [impressum typis haeredum Johannis Richteri], 1619.
127. *Epitome institutionum medicinae, et librorum de febribus*, Wittebergae, 1634.
128. *De Febribus libri IV, auctore Daniele Sennerto, ... Accessit ad calcem ejusdem de Dysenteria tractatus*, Lugduni: sumptibus J. Lautret, 1627
129. *De febribus libri IV. Authore Daniele Sennerto, ... Editio tertia auctior, cui accessit fasciculus medicamentorum contra pestem, Parisiis*, apud Societatem, 1633
130. Lyon, Paris, Amsterdam, Padua.
131. *Practica medicinae*, Venetiis: Bonetus Locatellus; impens. Octaviani Scoti, 27 junio, 1497.
132. De forma singular en: *Practica canonica de febribus*, Bononiae: Dionysius Bertochus, 8 marzo, 1487 y como *Canonica de febribus*, Pensis, Venecia, 1496. Asociado con otros tratados: *Practica canonica de febribus, de pulsibus, de urinis, de egestionibus, de Balneis omnibus Italiae, de vermibus*, Venetiis, 1498, 1503, 1552, 1563, Lyon 1560.
133. *Practica Savonarole de febribus. Canonica... De febribus. De pulsibus. De urinis. De egestionibus. De omnibus Italiae balneis. Tractatus sublimis de vermibus ...*, Venetiis per Lucantonium de Gionta Florentinum.
134. *Practica Savonarolae de febribus*. Venetiis, apud Ivntas, 1543.
135. *Practica Savonarolae De Febribus; Canonica Michaelis Savonarolae De febribus; De Egestionibus; De Pulsibus; De omnibus Italiae Balneis; De Vrinis; Tractatus sublimis de Vermibus. [...] Caesaris Optati Neapolitani artium & medicinae doctoris de hectica febre opus absolutum & nouum*, Venetiis: Apvd Ivntas, 1543.
136. *Practica canonica Ioannis Michaelis Sauonarolae, De febribus, De pulsibus, De vrinis, De egestionibus, De vermibus, De balneis omnibus Italiae. Huic accessit De hectica febre Caesaris Optati opusculum, vnaque Iacobi Syluij De omni februm genere Commentarius, & de eiusdem Gulielmi Verignanei duo Tractatus sanitati recuperandae commodissimi*, Lugduni: apud Sebastianum Honoratum y en la misma ciudad «excudebat Iacobus Faurus», ambas de 1560.
137. *Practica canonica de febribus Io. Michaelis Sauonarolae. Item de pulsibus. urinis. egestionibus. uermibus. balneis omnibus Italiae. Quae opera nunc emendatiora in lucem edimus, quam antea fuerunt. Caesaris Optati medici neapolitani, De hectica febre, opus absolutum. Index tum capitum, tum rerum omnium*, Venetijs: apud Vincentium Valgrisius, 1561.
138. *Practica Savonarolae de febribus: argelatae cum albuginis cirugia*, Venetiis: Juntas, 1543.
139. *Epistolae medicinales in quibus multa recentiorum errata et antiquorum decreta reserantes. Epistola Huberti Barlandi ad medicinae, apud Lovainenses studiosam iuventutem*, Ferrara, B. Odonino, 1521. Fue reeditado en París, 1528, Strasbourg, 1529, Bâle, 1540, Lyon 1549, Venecia, 1557, Hannover, 1611.
140. Consiste en la provocación de vesículas en la piel mediante sustancias irritantes. Era una variante de las sangrias o las ventosas, mediante la cual se trataba de derivar hacia otro lugar del cuerpo los humores causantes de determinada patología.
141. *Disputatio de phoenigmorum, quae vulgo vesicantia appellantur y de theriacae usu in febribus pestilentibus. In qua etiam de natura pestis, et pestilentium februm nonnulla tractantur*, Padua, Paulum Meietum, 1591. Fue ampliada y reeditada en 1593.
142. *De febribus tractatus numeris omnibus absolutus... Adjectus est capitum index & aquam cordialem componendi ratio, commentario illustrata ...*, Venetiis, Apud Alexandrum Polum, & Franciscum Bolzettam, 1620.
143. *De febribus tractatus numeris omnibus absolutus... Adjectus est capitum index & aquam cordialem componendi ratio, commentario illustrata ...*, Venetiis, Apud Alexandrum Polum, & Franciscum Bolzettam, 1620.
144. *De morbo pustulato sive lenticulari, quem nostrates Tavardillo apellant, liber unus, atque de Galeni placitis liber alter*, Zaragoza, Michaelis a Huessa, 1574. Hay edición moderna, con traducción, estudio introductorio y notas de J. R. Gurpegui, Bilbao, Museo Vasco de Historia de la Medicina y de las Ciencias "José Luis Goti" Medikuntza eta Zientzia Historiaren Euskal Museoa, 2003.
145. *Ex Hippocratis et Galeni monumentis Isagoge summa diligentia decerpta, ad faciendam medicinam non minus vtilis, quam necessaria / authore Ludouico Collado medico valentino*, Valentiae: ex typ. Joannis Mey, 1561. Seguramente la edición a la cual Rapó se refiere es la de igual título hecha también en Valencia por: Benedicti Mace..., 1674.
146. L. García Ballester (1971) «Las obras médicas de Luis Collado», *Asclepio*, vol. XXIII, págs. 263-270
147. *Vtilissima disputatio de dignotione et curatione februm, Auctore Vincentio Garcia, secunda editio locupletior, & emendatior*. Valentiae: Ex typographia Fuster, juxta Templum S. Martini. Expensis Joannis Laurentii Cabrera, 1652. Oportunamente corregido, fue reimpreso en 1656: *secunda editio locupletior, & emendatior*. Expensis Joannis Valentiae: ex Typographia Ioannis Laurentij Cabrera Bibliopoli[ae]... y 1682: *Tertia editio locupletior, et emendatior cum additione uniceae qu[ae]stiunculae in qua examinatur pulvis de Quarango, vulgo Cascarilla, in curatione tertianae & quartanae*, Valentiae: ex typographia Ioannis Laurentij Cabrera Bibliopolae: A costa de Francisco Duarte ... vendese en su casa.
148. Juan Bautista Orivay y de Monreal (1678) *D. Joan. Baptistae Orivai, sive Orivari et de Monreal ... Propugnaculum Hippocraticae ac Galenicæ doctrinae de februm putridarum in principijs per purgationem & sanguinis-missionem curatione : commentaria duo complectens quorum : I. De purgatione ... II. De sanguinis missione...*: accessit III. *Disputatio De antipodopnebotomia ...*, Lugduni: curâ & sumptibus Joan. Brugieres, M.DC.LXXVIX [i.e. 1678].
149. Juan Bautista Orivay y de Monreal (1679) *Theatro de la verdad, y claro manifesto del conocimiento de las enfermedades de la ciudad de Orihuela, del año 1678: pruebase no aver sido peste, ni su contagio, sino calenturas malignas con forma vulgar, nacidas de pobreza, hambre, malos alimentos, y destemplança del tiempo / defiendese la declaracion hecha en la Visita de Orihuela por Iuan Bautista Orivay y de Monreal*. En Zaragoza: por los herederos de Diego Dorner.
150. *Practicae Gotholanorum pro curandis humani corporis morbis, descriptae juxta medicinae rationalis leges, quas posteris commendatas reliquerunt lucidiora antiquitatis luminaria Hippocrates et Galenus*, Tomus primus, Barcelona, F. Cornellas, 1678. Reeditada en el mismo lugar por V. Surià en 1704).

Bizarre parosteal osteochondromatous proliferation (Nora's lesion): A case with acute and painful presentation

*Proliferación osteocondromática parosteal extraña (lesión de Nora):
Un caso de presentación aguda y dolorosa*

Seyed Hussein Saeed-Banadaky 

Department of Orthopedics, Trauma research Center, Shahid Sadoughi University of Medical sciences, Yazd, Iran

Corresponding author

Seyed Hussein Saeed-Banadaky

E-mail: h.saeed.b@gmail.com, horcyazd@gmail.com

Received: 28 - I - 2023

Accepted: 2 - III - 2023

doi: 10.3306/AJHS.2023.38.03.168

Abstract

Bizarre parosteal osteochondromatous proliferation, also known as Nora's lesion, is relatively rare benign lesions that develop in small bones of hands and feet. In this study, one case of this disease in the proximal phalanx of the right index of a 42-year-old man has been reported. Physical exam and clinical characteristics, clinical, radio graphical and pathologic findings suggested the presence of this lesion. There was not any history of trauma and injury and in the exam, we find pain and swelling, mild local tenderness, extra osseous calcification in x-ray, and mass with high signal in T2 was observed. The mass was removed by surgery and observation showed no malignant manifestations. The patient did not show recurrence or complications after surgery.

Key words: Osteochondromatous, Nora's lesion, Trauma, Injury.

Resumen

La proliferación osteocondromatosa parosteal extraña, también conocida como lesión de Nora, es una lesión benigna relativamente rara que se desarrolla en los huesos pequeños de las manos y los pies. En este estudio se reporta un caso de esta enfermedad en la falange proximal del índice derecho de un hombre de 42 años. El examen físico y las características clínicas, los hallazgos clínicos, radiográficos y patológicos sugirieron la presencia de esta lesión. No había antecedentes de traumatismos y lesiones y en el examen se encuentra dolor e inflamación, leve hipersensibilidad local, calcificación extraósea en la radiografía y se observa masa con alta señal en T2. La masa fue extirpada mediante cirugía y la observación no mostró manifestaciones malignas. El paciente no presentó recidiva ni complicaciones tras la cirugía.

Palabras clave: Osteocondromatoso, Lesión de Nora, Trauma, Lesión.

Background

Bizarre parosteal osteochondromatous proliferation (BPOP) was reported by Nora et al. for first time¹. It is also nomenclatures as Nora's lesion. This disease is a rare discomfort that occurs in small bones. However, large bone involvement has also been reported in some studies^{2,3}. This complication is benign and in most cases, the rate of growth and relapse is low⁴; however, in rare cases, it's possible that it is mistakenly considered as malignancy due to the high rate of recurrence, rapid growth and histological findings and observations. In 20-50 percent of reported cases, this is a diagnosis of malignancy due to atypical diagnostic findings and histopathologic appearance⁴. In this study, a case of this disease with symptoms of rapid growth and pain in proximal phalanx of the right index finger in a 42-year-old man was reported. The diagnostic findings and treatment of this patient were also mentioned.

Case presentation

The patient was a 42-year-old man with a complaint of pain and swelling in the proximal phalanx of the right index finger (**Figure 1**). In the early studies, there was no history of trauma and ulcers in this phalanx. There was also no history of diabetes and metabolic disease in this patient. Local swelling and its related tenderness were observed in the proximal phalanx. On palpation, a mildly tender mass with a fairly hard consistency was touched on the finger. The neurovascular exam and movements of the finger were intact.

Investigations if relevant

In x-ray, soft tissue swelling accompanied by extra-bone calcification and the adjacent proximal lining was evident (**Figure 2**). Also in MRI, a mass with a high

signal at T2 was evident (**Figure 3**). Other radiographic studies including x-ray of chest and lung were normal. Laboratory tests were also in normal range. According to the rapid growing history of mass and painfulness of the lesion, an incisional sampling was considered for further investigation. The patient was followed up for one year and no recurrence or other complication has ever been established.

Treatment

The surgery was planned by an oblique incision directly on the volar aspect of the proximal phalanx. We found a hard mass that was completely detachable from the proximal region. There was no atypical soft tissue around the mass. This mass had no clinical manifestations of malignancy and it was completely eliminated. So the lesion totally excised for microscopic examination. And the result was BPOP.

The patient was followed up for one year and no recurrence or other complication has ever been established

Figure 1: Anterior and posterior view, patient Rt hand.

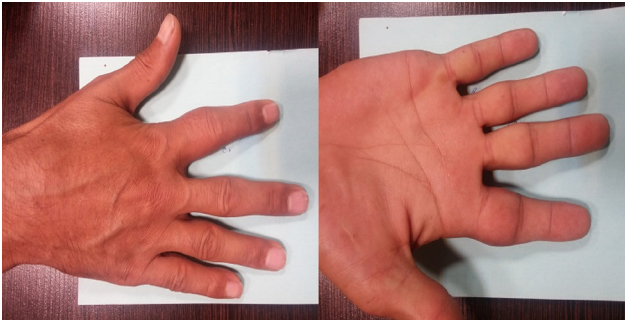

Figure 2: Plain X-ray ,patient Rt hand ,AP and Lateral.



Discussion

BPOP or Nora is a rare condition that occurs in the form of mass in small bones. But, it is also reported in some other bones, such as the humerus, radius, etc^{5,6}. The distribution of this type of disease is almost identical between men and women and there is no gender preference. The age distribution of this disease is greater in the range of 20-30 years old, although it can occur at different ages². In our study, the patient's age was 42 years. The observed masses exhibit Histopathologically and radiographically distinctive features. In most cases, the history of trauma and infection has not been reported. The history of trauma has not also been mentioned in the reports of the patient in this study. In most cases, the lesion has been reported in the bones of the hand, and few cases have reported the disease in the bones of the leg¹. The location of the lesion in the patient in this study, as in most cases reported in the hands, was in the proximal phalanx of the right index finger. The initial treatment of this disease is surgery, and since the lesion is benign, treatment is well-suited⁷. Removal of adjacent abnormal tissues is also recommended during surgery. Excessive resection is also not permitted, as it may result in loss of function especially in the hands and feet³. In our study, we also easily removed the mass and abnormal adjuvant tissue. In some cases, recurrence of the disease has been reported. These lesions tend

Figure 3: MRI ,T1 and T2 sequences and in different sections.

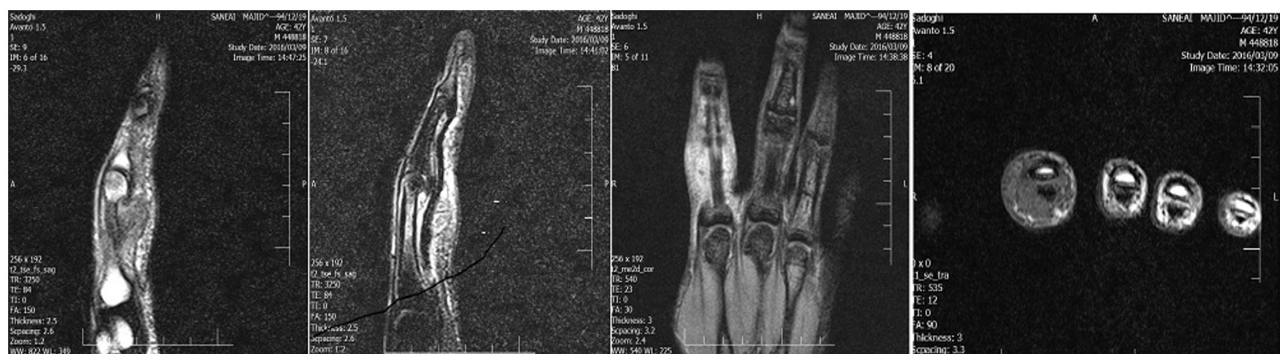

to be significantly reversible: relapse rates have been reported between 29-55% for a 2-year period, with almost half of these patients have been experienced the second recurrence. In terms of metastasis and mortality, no cases have ever been reported. The present study confirms this issue. The BPOP radiographic and microscopic features are reported in all reported cases as key points for the diagnosis and characterization of this disorder. These characteristics have led to confusion with other cases such as osteochondroma, osteosarcoma, chondrosarcoma and so on⁸. The best way to detect this lesion from osteochondroma is histopathologic findings. The distinction between BPOP and osteochondroma is important so that BPOP is more likely to require invasive surgery than osteochondroma and it has a higher rate of relapse⁹. In our study, the definitive diagnosis of this complication was determined by examination of histology and pathology. The first stage of BPOP appears as swelling of the soft tissue with or without quantitative calcification³. In this study, radiographic studies confirmed that there was a soft tissue swelling associated with extra osseous calcification, and the two-month disease history and painfulness of the lesion showed a possibility of mass malignancy. But during surgery, the result was a lack of malignancy in the mass. Gerald Gruber et al reported three cases of BPOP disease with symptoms of increased volume, pain without any history of trauma. In their report, the radiographic features of the calcified masses were involved in tissues around the bone. In MRI studies, there was also a mass with a high signal at T2. Yuichiro Matsui et al recorded calcification of the surrounding tissue and high signal in T2 in their

case¹⁰. Typically, the mass has a low signal in T1 and a moderate to high signal in T2⁹. The radiographic characteristics of our studied case were similar to those of the above studies so that the mass with calcification and the high signal was observed Nora et al., Dhont et al., and Meneses et al. Reported local relapse of 51%, 29%, and 55%, respectively². In this study, the patient did not show any recurrence or other complications after the one-year post-surgical follow-up. In some cases, the time between the first resection and recurrence was two months. Our patient did not show any recurrence in the follow-up. According to the observations of this study and comparison with other reported cases, due to the similarities between the disease and the osteochondroma (although it is rare)⁸, it is difficult to detect this tumor precisely during the diagnosis process and it may be misdiagnosed. Painfulness of the lesion and quick clinical course are two important difference of our case with other reported cases.

- The use of hybrid diagnostic methods including radiographic, microscopic and histopathologic techniques for diagnosis of this disease is suggested
- Surgical procedure along with the removal of adjacent abnormal tissue is recommended as an effective treatment.

Follow-up of the patient for the possibility of recurrence and complication is recommended.

Competing interests

Author has declared that he have no competing interests.

References

1. Nora FE, Dahlin DC, Beabout JW. Bizarre parosteal osteochondromatous proliferations of the hands and feet. *Am J Surg Pathol.* 1983; 7(3): 245-50.
2. Meneses MF, Unni KK, Swee RG. Bizarre parosteal osteochondromatous proliferation of bone (Nora's lesion). *Am J Surg Pathol.* 1993; 17(7): 691-7.
3. Dhondt E, Oudenhoven L, Khan S, et al. Nora's lesion, a distinct radiological entity? *Skeletal Radiol.* 2006; 35(7): 497-502
4. Barrera-Ochoa S, Lluca A, Gargallo-Margarit A, Pérez M, Vélez R. Bizarre Parosteal Osteochondromatous Proliferation (Nora's Lesion) of the Hand: A Report of Two Atypical Cases. *Case Reports in Medicine.* 2012; 2012:1-9.
5. Abramovici L, Steiner GC. Bizarre parosteal osteochondromatous proliferation (Nora's lesion): a retrospective study of 12 cases, 2 arising in long bones. *Hum Pathol.* 2002; 33(12): 1205-10.
6. Bush JB, Reith JD, Meyer MS. Bizarre parosteal osteochondromatous proliferation of the proximal humerus: case report. *Skeletal Radiol.* 2007; 36(6): 535-40.
7. Gruber G, Giessauf Ch, Leithner A, et al. Bizarre parosteal osteochondromatous proliferation (Nora lesion): a report of 3 cases and a review of the literature. *Can J Surg.* 2008; 51(6): 486-9.
8. Michelsen H, Abramovici L, Steiner G, Posner MA. Bizarre parosteal osteochondromatous proliferation (Nora's lesion) in the hand. *J Hand Surg Am.* 2004; 29(3): 520-5.
9. Chamberlain AM, Anderson KL, Hoch B, Trumble TE, Weissstein JS. Benign Parosteal Osteochondromatous Proliferation of the Hand Originally Diagnosed as Osteochondroma: A Report of Two Cases and Review. *Hand (N.Y).* 2010; 5(1): 106-110.
10. Matsui Y, Funakoshi T, Kobayashi H, Mitsuhashi T, Kamishima T, Iwasaki N. Bizarre parosteal osteochondromatous proliferation (Nora's lesion) affecting the distal end of the ulna: a case report. *BMC Musculoskeletal Disorders.* 2016; 17: 130.

CASE REPORT

Timely diagnosis of thyroid carcinoma in a young woman presenting to primary care during COVID-19 pandemic lockdown: from ultrasound to pathology

Diagnóstico oportuno de carcinoma de tiroides en una mujer joven que acudió a atención primaria durante el confinamiento por la pandemia de COVID-19: de la ecografía a la patología

Laura Hrehová¹ , Kamal Mezian² 

1. Institute of General Practice, First Faculty of Medicine, Charles University, Prague, Czech Republic 2. Department of Rehabilitation Medicine, Charles University, First Faculty of Medicine and General University Hospital in Prague, Czech Republic

Corresponding author

Laura Hrehová, MD, MBA
E-mail: laura.hrehova@gmail.com

Received: 30 - I - 2023

Accepted: 8 - III - 2022

doi: 10.3306/AJHS.2023.38.03.171

Abstract

Papillary thyroid carcinomas (PTC) are the most common type of thyroid malignancy that usually presents as a palpable or non-palpable nodule. Some of these nodules may cause hoarseness, swallowing, and breathing problems.

In this paper, we present a case of PTC with fatigue as the leading symptom. The suspicion for thyroid disease was made upon palpation of the thyroid nodule during a periodic preventive care visit by a general practitioner during the peak of the COVID-19 pandemic in April 2020. Further management consisted of fine-needle aspiration, total thyroidectomy, radioactive iodine, and life-long medication of levothyroxine.

Presenting this case, we would like to emphasize the paramount role of periodic preventive care visits even during such a challenging time as the COVID-19 pandemic definitely is.

Key words: ultrasonography, endocrinology, coronavirus, tumor, periodic visit.

Resumen

Los carcinomas papilares de tiroides (CPT) son el tipo más común de neoplasia tiroidea que suele presentarse como un nódulo palpable o no palpable. Algunos de estos nódulos pueden causar ronquera, problemas para tragar y respirar. En este trabajo presentamos un caso de PTC con fatiga como síntoma principal. La sospecha de enfermedad tiroidea se hizo al palpar el nódulo tiroideo durante una visita periódica de atención preventiva realizada por un médico general durante el pico de la pandemia de COVID-19 en abril de 2020. El tratamiento posterior consistió en una aspiración con aguja fina, tiroidectomía total, yodo radiactivo y medicación de por vida con levotiroxina.

Al presentar este caso, nos gustaría enfatizar el papel primordial de las visitas periódicas de atención preventiva, incluso durante una época tan desafiante como es definitivamente la pandemia de COVID-19.

Palabras clave: ecografía, endocrinología, coronavirus, tumor, visita periódica.

Introduction

In March 2020, the coronavirus disease (COVID-19) pandemic appeared 'out of the blue', and the health care system worldwide faced unexpected challenges. This unprecedented strain resulted in prioritization towards the management of COVID-19 cases. Hence, periodic preventive care visits performed by general practitioners, including cancer screening, have plummeted during the COVID-19 pandemic lockdown. Concurrently,

people avoided attending health care facilities because of concerns about being infected with COVID-19. As such, there was a rapid transfer from face-to-face examination to telehealth in primary care since March 2020. On the other hand, our center (as many others) encouraged patients to attend periodic preventive care visits as scheduled.

Herein, we report a case of a young woman who was diagnosed with papillary thyroid carcinoma (PTC) upon a periodic preventive care visit during COVID-19 pandemic lockdown.

Case report

At the end of April 2020, a 32-yrs woman, an office worker of Vietnamese origin living in the Czech Republic, presented to our primary care center for a scheduled periodic preventive care visit. She reported fatigue, which she linked with an increased workload. She denied any other symptoms possibly related to hyper or hypofunction of the thyroid gland. Her medical history included breast augmentation surgery for esthetic reasons. She was otherwise healthy and did not seek any regular medical treatment. She reported no history of radiation exposure or a family history of thyroid disorders. Her current physical examination revealed a palpable, immobile, nonpainful mass in her thyroid gland's right lobe. No cervical nodes were palpable. Upon focused questioning about this region, she admitted an anterior neck discomfort/'foreign-body' sensation in the last month. She denied hoarseness, any swallowing, and breathing problems.

Subsequent laboratory testing (including serum thyrotropin (TSH) and free T4) showed no abnormalities (TSH – 0.24 mIU/L and fT4 – 18.0 pmol/L, respectively). The ultrasound (US) examination revealed an isoechoic, non-homogenous, oval-shaped, well-margined node in the right lobe of the thyroid gland, measuring 22 mm by 18 mm by 16 mm (volume, 35 mm³) (Figure 1A,B). Upon power Doppler evaluation, the node showed no hypervascularisation. In the lateral part of the left lobe,

three small cystic structures measuring 3 mm by 3 mm by 5 mm were present (Figure 1C,D). CA: carotid artery

Isthmus of the thyroid did not show any US abnormalities. The thyroid gland was not enlarged, and its morphology was otherwise homogenous. There was no cervical adenopathy in both the central and lateral neck compartments. A US-guided fine-needle aspiration (FNA) with cytologic evaluation was performed from the node, which showed hypercellularity, nuclear enlargement, and a few nuclear pseudoinclusions. The finding was interpreted as consistent with the diagnosis Bethesda VI (97-99 % risk of malignancy)², with predominant characteristics of papillary carcinoma. Considering the cytopathologic and US characteristics of the node, a total thyroidectomy was performed at the end of August 2020. Endotracheal intubation during general anesthesia was difficult, thus requiring videolaryngoscopy assistance. After the surgery, no signs of damage to the recurrent laryngeal nerve or other complications occurred. Grossly, the excision material of the right lobe of the thyroid gland contained an irregular shaped greyish white tumor, measuring 15 mm by 15 mm by 10 mm. Subsequently, microscopic examination showed solid, follicular, and particularly papillary proliferations - consistent with the diagnosis of the follicular variant of PTC pT1b (Figure 2).

Postsurgically, the patient was prescribed life-long medication of levothyroxine. She recently finished an adjuvant treatment with radioactive iodine (¹³¹I). On follow-up in our primary care center in the middle of December 2020, the patient was free of symptoms, with no functional limitations. The timeline of this case management is shown in figure 3.

Figure 1: The horizontal (A) and vertical (B) ultrasound (US) images of the thyroid gland show an isoechoic, non-homogenous, oval-shaped, well-margined node (white arrowheads) in the right lobe, measuring 22 mm by 18 mm by 16 mm (volume, 35 mm³). In the lateral part of the left lobe, three small cystic structures (white arrow) measuring 3 mm by 3 mm by 5 mm were apparent in the horizontal (C) and vertical planes (D).

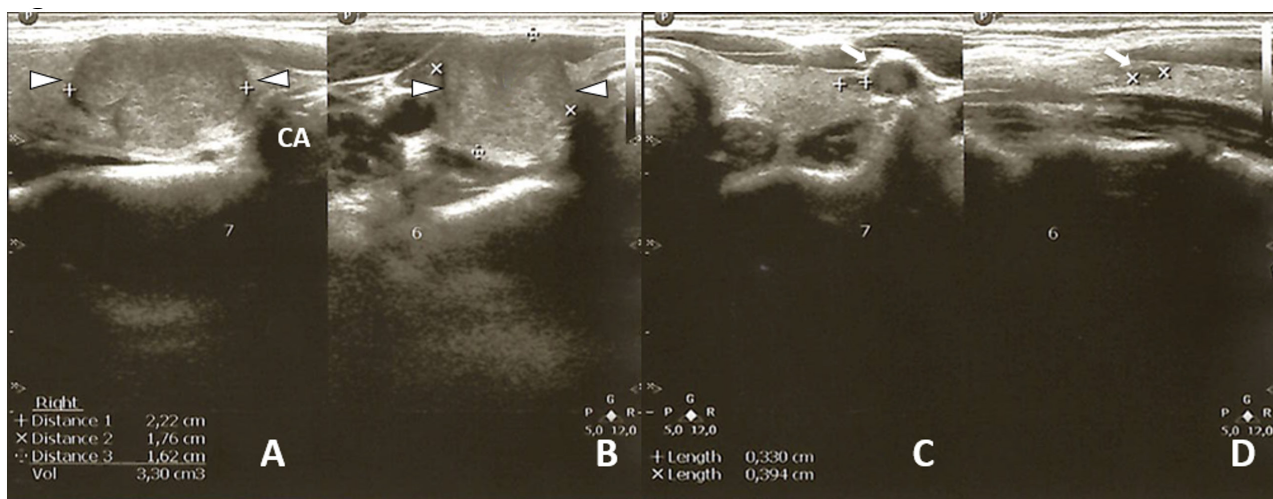

Figure 2: Histopathological evaluations were performed from formalin-fixed, paraffin-embedded tissue blocks stained with hematoxylin-eosin. Microscopic examination of the excision material from the right lobe of the thyroid gland showed a malignant proliferation (white arrow) with fibrous tissue areas (magnification 40x) (A). A magnification 400x showed solid, follicular, and typical papillary proliferations (asterisk) surrounded by ground-glass nuclei (white arrowheads) - consistent with the diagnosis of the follicular variant of PTC with areas of fibrous tissue (B).

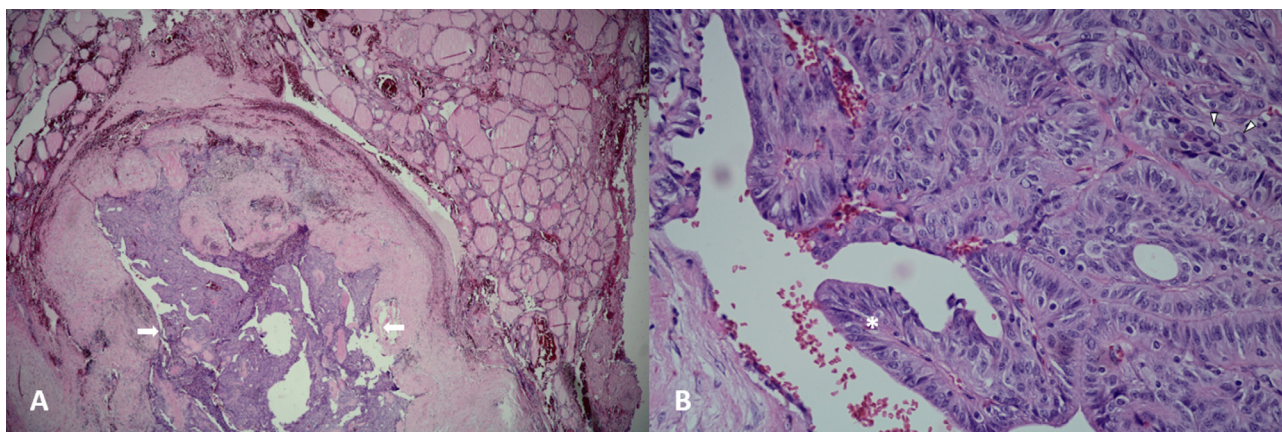
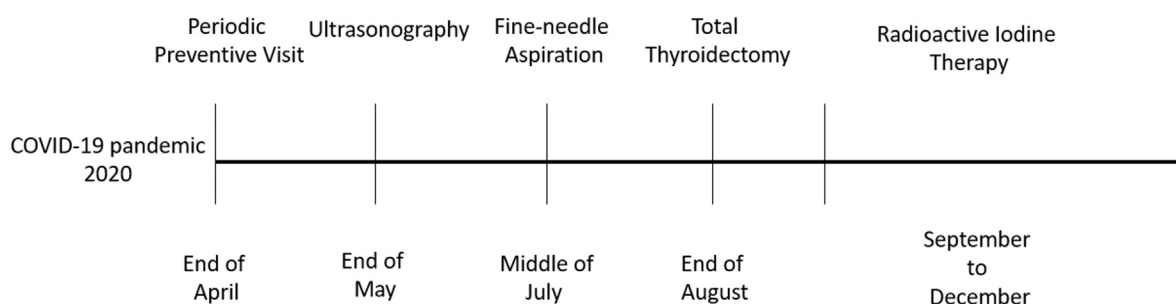

Figure 3: The timeline illustrates the management of the patient diagnosed with papillary thyroid carcinoma during COVID-19 pandemic lockdown.



Discussion

PubMed, Web of Science, and Scopus databases were searched for COVID-19 pandemic and thyroid cancer relevant articles to December 2020. We restricted our search only to articles written in English. We have used the following keywords for the literature search: Thyroid Gland, Thyroid Nodule, Thyroid Cancer, Thyroid Neoplasms, COVID-19, General Practice, Thyroid Ultrasound.

Differentiated thyroid tumors (DTT) arising from follicular cells are classified as papillary (comprising 80% of all cases) and follicular (10-20% of all cases); and those that grow up from parafollicular cells are neuroendocrine medullary thyroid tumors (6-8% of all cases). Some cases of DTT can dedifferentiate into aggressive anaplastic thyroid cancer³.

In this case report, we describe a timely diagnosis and further management of PTC in a young woman during the peak of the COVID-19 pandemic. Since March 2020, telemedicine was considered the mainstay of some primary care centers¹. However, as Tsang and coworkers state in their recent review, assessment for thyroid

nodules is inappropriate without physical examination and ultrasound. Furthermore, the availability of FNA for thyroid nodules was reported to be limited during the COVID-19 pandemic⁴. As documented by Williams and colleagues, COVID-19-related health care restrictions resulted in delayed diagnosis in 16% of patients⁵. As such, the delay of diagnosis and surgery in patients with cancer might increase the likelihood of disease progression with a concomitant long-term survival decrease⁶.

Our approach was in contrast with the published clinical practice expert consensus by Vrachimis and colleagues, who recommended postponement of different aspects of thyroid disease management (e.g., scheduled US evaluations of thyroid nodules, biochemical examinations, diagnostic appointments for all patients with un-/newly diagnosed thyroid cancer, non-urgent surgery, even those with cytologically confirmed differentiated thyroid cancer)⁷.

A PTC is the most common endocrine malignancy⁸, and when timely and appropriately treated, a good prognosis with ten years of survival in more than 90%

of patients is likely⁹. A leading symptom in the case we present here in this report was fatigue. As this symptom is nonspecific, and the sensitivity of palpation in detecting thyroid nodules is generally low¹⁰, a timely diagnosis of malignant thyroid disease with nodules can be challenging in some cases. Fortunately, clinicians increasingly use US examination in their routine practice (i.e., as an extension of physical examination), and they can efficiently catch thyroid nodules. US can provide preliminary evaluation regarding their cancerous US features (e.g., nodules ≥ 1 cm, blurred margins, nonrounded shape, microcalcifications, echogenicity, vascularity)^{11,12}, and is also a convenient tool for image-guided FNA^{13,14}. In addition, cervical lymphadenopathy should also be ruled out by using US¹². To this end, high-resolution US imaging can significantly facilitate the diagnostic and therapeutic algorithms in patients with suspected thyroid disease. Of note, US imaging is inexpensive, noninvasive, repeatable, well accepted by both patients and physicians, and does not expose patients to ionizing radiation. It also allows immediate correlation between imaging, laboratory, and clinical findings. Yet, the US probe is becoming the 'stethoscope' or 6th finger of clinicians across different specialties¹⁵.

Conclusion

Presenting this otherwise trivial case of malignant thyroid tumor, we would like to emphasize the paramount role of periodic preventive care visits even during such a challenging time as the COVID-19 pandemic definitely is. In this case of a timely diagnosis of PTC in a young woman, we want to illustrate how the primary health care system is essential to avoid a negative impact on oncologic patients' long-term survival. In other words, by this positive example, we stress that avoiding periodic preventive care visits for different reasons (e.g., for concern about catching infectious disease) might also have the other side of the coin.

The patient consented to be presented in this case report.

Competing interests

None.

Funding or grants or equipment provided for the project from any source

None.

Financial benefits to the authors

Supported by MH CZ DRO-VFN 64165

References

- Greenhalgh T, Koh GCH, Car J. Covid-19: a remote assessment in primary care. *BMJ*. 2020; 368: m1182.
- Cibas ES, Ali SZ; NCI Thyroid FNA State of the Science Conference. The Bethesda System For Reporting Thyroid Cytopathology. *Am J Clin Pathol*. 2009; 132: 658-65.
- Schneider DF, Chen H. New developments in the diagnosis and treatment of thyroid cancer. *CA Cancer J Clin*. 2013; 63: 374-94.
- Tsang VHM, Gild M, Glover A, Clifton-Bligh R, Robinson BG. Thyroid cancer in the age of COVID-19. *Endocr Relat Cancer*. 2020; 27: R407-R416.
- Williams R, Jenkins DA, Ashcroft DM, Brown B, Campbell S, Carr MJ, et al. Diagnosis of physical and mental health conditions in primary care during the COVID-19 pandemic: a retrospective cohort study. *Lancet Public Health*. 2020 Oct;5(10):e543-e550. doi: 10.1016/S2468-2667(20)30201-2.
- Sud A, Jones ME, Broggio J, Loveday C, Torr B, Garrett A, et al. Collateral damage: the impact on outcomes from cancer surgery of the COVID-19 pandemic. *Ann Oncol*. 2020 Aug;31(8):1065-1074. doi: 10.1016/j.annonc.2020.05.009. Epub 2020 May 19.
- Vrachimis A, Iakovou I, Giannoula E, Giovanella L. ENDOCRINOLOGY IN THE TIME OF COVID-19: Management of thyroid nodules and cancer. *Eur J Endocrinol*. 2020; 183: G41-G48.
- Ito Y, Kihara M, Takamura Y, Kobayashi K, Miya A, Hirokawa M, et al. Prognosis and prognostic factors of papillary thyroid carcinoma in patients under 20 years. *Endocr J*. 2012; 59: 539-45.
- Cisco RM, Shen WT, Gosnell JE. Extent of surgery for papillary thyroid cancer: preoperative imaging and role of prophylactic and therapeutic neck dissection. *Curr Treat Options Oncol*. 2012; 13: 1-10.
- Tan GH, Gharib H. Thyroid incidentalomas: management approaches to nonpalpable nodules discovered incidentally on thyroid imaging. *Ann Intern Med*. 1997; 126: 226-31.
- Grant EG, Tessler FN, Hoang JK, Langer JE, Beland MD, Berland LL, et al. Thyroid Ultrasound Reporting Lexicon: White Paper of the ACR Thyroid Imaging, Reporting and Data System (TIRADS) Committee. *J Am Coll Radiol*. 2015 Dec;12(12 Pt A):1272-9. doi: 10.1016/j.jacr.2015.07.011.
- Burman KD, Wartofsky L. CLINICAL PRACTICE. Thyroid Nodules. *N Engl J Med*. 2015; 373 : 2347-56.
- Rosen JE, Stone MD. Contemporary diagnostic approach to the thyroid nodule. *J Surg Oncol*. 2006; 94: 649-61.
- Wong KT, Ahuja AT. Ultrasound of thyroid cancer. *Cancer Imaging*. 2005; 5: 157-66.
- Özçakar L, De Muyneck M, editors. *Musculoskeletal Ultrasound in Physical and Rehabilitation Medicine*. Milano: Edi-Ermes; 2014.

CASE REPORT

Una mordedura inusual

*An unusual bite***Juan Martínez-Andrés¹** , **Irene Ferrando-Fabra²**, **Patricia Martínez-Andrés³**

1. Servicio de Medicina Interna, Hospital Can Misses, Ibiza (Islas Baleares), España

2. Atención Primaria, Centro de Salud Es Viver, Ibiza (Islas Baleares), España

3. Cirugía Plástica, Hospital Virgen del Consuelo, Valencia (Comunidad Valenciana), España

Corresponding author

Juan Martínez-Andrés

E-mail: juan.martinezand@gmail.com

Received: 31 - I - 2023**Accepted:** 10 - III - 2023**doi:** 10.3306/AJHS.2023.38.03.175**Resumen**

Varón de 19 años galés sin antecedentes que presencia la mordedura de un arácnido marronáceo en la mano derecha en una zona rocosa cercana al mar en horario vespertino. Debut con dolor difuso, eritema, edema, datos sugestivos de baja perfusión tisular de forma centrífuga y gravitacional que evolucionan a necrosis tisular además de formación de flictenas. Sin hallazgos significativos en pruebas complementarias. Se consigue identificar la etiología: *Loxosceles rufescens*, por lo que se trata de un caso de loxocelismo cutáneo necrótico grave. Dada la ausencia de tratamiento específico recibe terapia analgésica, antibioterapia empírica con Piperacilina-Tazobactam y Linezolid, anticoagulación con Enoxaparina, Metilprednisolona, Alprostadil y empleo de cámara hiperbárica. Las lesiones se delimitan y se descarta abordaje quirúrgico con amputación espontánea de falanges media y distal de segundo y tercer dedo y distal del quinto con preservación sensorial de los territorios.

Palabras clave: mordedura, *loxosceles rufescens*, loxocelismo.

Abstract

19-year-old Welsh male with no medical history who witnessed a brownish arachnid bite on his right hand in a rocky area in a seaside area in the evening. Debuts with diffuse pain, erythema, edema, suggestive low tissue perfusion in a centrifugal and gravitational distribution that evolves to tissue necrosis in addition to the formation of blisters. No significant findings in complementary tests. Etiology is identified: *Loxosceles rufescens*, so it is a case of severe necrotic cutaneous loxocelism. Given the absence of specific treatment, he receives analgesic therapy, empirical antibiotic therapy with Piperacillin-Tazobactam and Linezolid, anticoagulation with Enoxaparin, Methylprednisolone, Alprostadil and use of a hyperbaric chamber. The lesions are progressively delimited and a surgical approach was ruled out, producing spontaneous amputation of the middle and distal phalanges of the second and third fingers and distal of the fifth with sensory preservation of the territories.

Key words: bite, *loxosceles rufescens*, loxocelism.

Caso

Varón de origen galés de 19 años sin alergias ni antecedentes de interés, así como tampoco tratamiento habitual que se encuentra desde hace un mes de vacaciones en la isla de Ibiza por motivos de ocio.

El paciente refiere que en la tarde de ayer se encontraba viendo la puesta de sol desde una zona rocosa a unos 10 metros de la orilla del mar, cuando, tras introducir

su mano derecha entre dos rocas refiere sensación de discreto pinchazo a nivel del segundo dedo, así como la presencia de un arácnido marronáceo del que no sabe especificar más información.

Tras este acontecimiento, el paciente decide volver a su domicilio donde comienza a presentar astenia. Se despierta a las 6 horas del acontecimiento con

percepción de dolor tipo quemazón de distribución difusa en la mano derecha que se acompaña de edematización (**Figura 1**), así como fiebre termometrada de 38°C y malestar generalizado. Por este motivo consulta en una clínica privada, donde se le prescribe Amoxicilina-Clavulánico 875/125mg cada 8 horas, así como Metilprednisolona 40mg intramuscular. Tras la vuelta a su domicilio y ante persistencia del malestar, así como el cambio de coloración de algunos de sus dedos, acude al departamento de Urgencias.

Asu llegada el paciente se encuentra hemodinámicamente estable (Tensión arterial: 133/89mmHg, frecuencia cardíaca: 100 latidos por minuto) y febril (temperatura axilar: 38.7°C). A la exploración los únicos hallazgos son a nivel del miembro afecto, donde se aprecia un eritema y edematización hasta el tercio proximal con presencia de flictenas no purulentas de 10 x 8 cm en la región palmar, así como cianosis establecida en 2°, 3° y 5° dedos ipsilaterales.

Se extrae analítica sanguínea en la que se aprecia marcada leucocitosis con 27010 unidades con desviación izquierda (Neutrófilos: 26300), Proteína C Reactiva de 263.5mg/L y Creatina quinasa de 308U/L.

Se realiza radiografía de tórax y electrocardiograma sin hallazgos relevantes y Tomografía Computerizada del miembro superior derecho que describe extenso edema y engrosamiento de la piel y tejido celular subcutáneo del antebrazo, mano y en menor medida del brazo derecho, afectando principalmente a su vertiente dorsal; sin afectarse la musculatura profunda ni haber colecciones.

Figura 1



Por este motivo se inicia de forma empírica Piperacilina-Tazobactam y Linezolid, sueroterapia, anticoagulación profiláctica y analgesia de primer y segundo escalón y queda ingresado a Medicina Interna, donde a las 32 horas de evolución presenta la siguiente afectación (**Figura 2**).

En el proceso de diagnóstico diferencial se contemplan:

- Infeccioso:
 - Bacterias
 - Streptococcus pyogenes*
 - Staphylococo aureus*
 - Enfermedad de Lyme
 - Anthrax*
 - Rickettsia*
 - Tularemia
 - Embolismo séptico
 - Ectima gangrenoso
 - Virus (Virus Herpes Simple / Virus Varicela Zoster)
- Inflamatorio:
 - Síndrome antifosfolípido
 - Vasculopatía livedoide
 - Enfermedad vasoclusiva
 - Crioglobulinemia
 - Vasculitis necrotizante
 - PAN
- Neoplásico:
 - Leucemia cutis
 - Neoplasia primaria cutánea
 - Papulosis linfomatoide
- Exógeno
 - Quemadura
 - Artrópodos

Se solicitaron los exámenes complementarios para descartar dichas posibilidades y finalmente se decanta por la etiología exógena, en concreto por la mordedura de una araña visualizada por el paciente.

Figura 2



En nuestro entorno tan solo se consideran dos especies con significancia médica:

- *Latrodectus tredecimguttatus* o viuda negra Mediterránea
- *Loxosceles rufescens* o araña rinconera o violinista

Dado que no se ha descrito la presencia de la *Latrodectus tredecimguttatus* en la isla de Ibiza así como tampoco se corresponde a la descripción del paciente y sí de la *Loxosceles rufescens*¹, se decanta por esta segunda opción. Por este motivo, se estableció contacto con la Dirección Insular de Sanidad quienes investigaron la zona de los hechos y se objetivaron diversos nidos de *Loxosceles rufescens* con abundantes ejemplares de los que fueron recogidos un par para ser verificados posteriormente.

Dada la orientación diagnóstica expuesta, el paciente recibe la explicación de la inexistencia de un tratamiento específico con evidencia científica sólida que lo respalde, pero dada la progresión de las lesiones, tanto él como su padre presente aceptan los tratamientos propuestos siguientes:

1. Analgesia que requiere escala hasta de tercer escalón a la hora de las curas de las lesiones.
2. Antibioterapia empírica durante 2 semanas con Piperacilina-Tazobactam y Linezolid.
3. Inicialmente se anticoaguló profilácticamente con Enoxaparina 40mg subcutánea, que se amplió hasta dosis terapéuticas (1mg/kg/día) dada la supuesta presencia de microtrombosis a nivel más distal.
4. Metilprednisolona 80mg endovenoso durante los cinco primeros días con desescalada posterior.
5. Alprostadil 40mg cada 12 horas endovenoso durante 7 días
6. 8 sesiones de cámara hiperbárica

La evolución de las lesiones es la siguiente:

- 3 días de evolución: necrosis en zona dorsal de primer dedo y casi en la totalidad de 2 y 3 dedo de manera circunferencial así como el quinto dedo. Asimismo, flictenas ya desbridadas sin otros signos de infección.
- 5 días de evolución: la necrosis antes mencionada es franca y aparece zona de sufrimiento cutáneo en zona hipotenar así como edematización de la misma.
- 8 días de evolución (**Figura 3**): tras la cura abrasiva, se desprende zonas cutáneas necrosadas que muestran zonas parciales de lecho con cierta viabilidad tisular en segundo y tercer dedo. La edematización y necrosis previamente observadas evolucionan estableciéndose el carácter distal de las lesiones

- 14 días de ingreso: el servicio de Traumatología plantea la amputación de segundo, tercer y quinto dedo, pero ante la no delimitación actual de las heridas la estabilidad actual del paciente y ante un proceso que iba a demorar varias semanas, se recomienda al paciente la vuelta a su país de origen para continuar con las curas y el seguimiento, así como quedar pendiente de posible intervención quirúrgica.
- 21 días: necrosis franca de falanges distales de segundo, tercer y quinto dedo, así como la granulación de las zonas más proximales de dichos dedos.
- 2 meses: Proceso de maduración de las lesiones
- 3 meses: Caída de falange distal. Cura por segunda intención del quinto dedo con buena recuperación del pulgar
- 5 meses y dos semanas: se observa la amputación espontánea de última falange y media de segundo y tercer dedo, así como de última del quinto y recuperación de la integridad cutánea del resto.
- Tras 7 meses, este es el estado actual de la mano del paciente (**Figura 4**). Se decidió la autodelimitación del tejido viable perdiéndose la falange distal del segundo y tercer dedo. Importante destacar que el paciente ha preservado la sensibilidad del territorio que ha mantenido, lo que, a pesar de lo molesto de la duración del tratamiento, ha hecho preservar mucha mayor funcionalidad a su mano dominante que en el caso de haberse amputado.

Figura 3



Figura 4

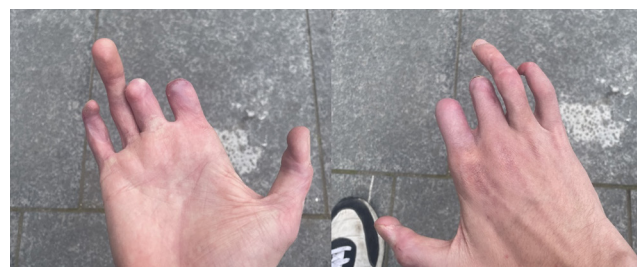

Discusión

Loxosceles rufescens se ha encontrado en países de la cuenca mediterránea confirmándose repetidamente su presencia a través de varias publicaciones², que subrayan su importancia médica. Nuestro caso se suma a estos crecientes informes de loxoscelismo en nuestra área.

El caso presentado ilustra algunas de las dificultades en el diagnóstico y tratamiento del loxoscelismo³. La no inclusión de esta entidad en el diagnóstico diferencial ha sido motivo de prescripción antibiótica ante la sospecha de celulitis con resultados fútiles, dada la evidencia de la ausencia de vectorización bacteriana a través de dichos arácnidos.

Coincidimos en que ante la sospecha de un caso de loxoscelismo cutáneo hay que descartar primero infecciones cutáneas que han sido atribuidas erróneamente a mordeduras de araña en algunas comunicaciones. Sin embargo, en áreas endémicas se debe considerar el loxoscelismo cuando los pacientes presentan antecedentes y hallazgos físicos compatibles, especialmente si los tratamientos ante la sospecha de celulitis parecen ineficaces⁴.

El bajo número de casos descritos en la literatura científica también se relaciona con que para la descripción de un caso verificado se requieren los siguientes requisitos:

1. Observar a la araña mordiendo al paciente
2. Capturarla durante o en momentos posteriores
3. Identificación del ejemplar
4. Sintomatología típicamente asociada a esta especie

Dado que no existen datos patognomónicos, la clínica únicamente se emplea como orientativa, pero no como diagnóstica. Por otra parte, no existe como tal ninguna prueba de laboratorio específica, así como sí lo hay para la *Loxosceles reclusa*, para la que se ha desarrollado un test de ELISA con elevada sensibilidad y especificidad que se desarrolla a través de una pequeña muestra del área afecta y cuya principal ventaja es que se puede realizar hasta 21 días después de la misma.

Por todo esto, es fácil comprender que la tasa de picadura verificadas sea baja en comparación con otras especies. Tal es así que tan solo se han verificado 12 casos de los 112 publicados a nivel global.

En contraste con la mayoría de las arañas venenosas cuyos compuestos son neurotoxinas, el principio activo del veneno de la *Loxosceles rufescens* es la fosfolipasa D, también conocida como esfingomielinasa D. Ésta se encarga de hidrolizar la esfingomielina de la membrana externa celular, resultando en la formación de colina y ceramida-1-fosfato. Esta reacción genera inflamación a través de las IL-1 y 6 así como la

activación del complemento. Todo esto resulta en dermonecrosis, hemólisis, trombocitopenia y fracaso renal en mamíferos.

La evolución de la mordedura de nuestro paciente se trata de una progresión grave dentro de las mismas dada la aparición de necrosis extensa en la zona afecta con predominio gravídico, siendo consistente con la descripción en la literatura de estos casos. No podemos hablar de un cuadro sistémico o visceral dada la ausencia de anemia hemolítica, trombocitopenia fallo renal y CID.

No existe un perfil determinado de paciente en cuanto a edad ni sexo, pero suele coincidir en la descripción de la enfermedad actual el desarrollo de la misma en el ámbito doméstico como resultado de estar vistiéndose o calzándose, dada la tendencia de estos arácnidos de refugiarse en pequeños rincones y de únicamente atacar como última línea de defensa. Por lo anterior se entiende que las regiones más afectas con las extremidades y la cara.

El lugar de la misma puede ser identificado como dos pequeños puntos cutáneos con un eritema perilesional, que no se describe como muy doloroso de forma inicial, de hecho, en algunos casos pasa inadvertido hasta 12 horas más tarde, cuando da comienzo un dolor de tipo quemazón así como en ocasiones prurito que se intensifica hasta las primeras 72 horas. La mordedura, por lo general, se aprecia como una pápula eritematosa que característicamente desarrolla una palidez central y en ocasiones vesículas perilesionales.

En la mayoría de los casos esta lesión se autolimita sin mayores complicaciones con una resolución a las 2-3 semanas. En los casos más graves, como el nuestro, se presentan áreas isquémicas y un importante eritema con edema asociado, usualmente con una extensión centrífuga y gravitacional, que a partir del tercer día tiende a delimitarse, y suele desarrollarse una necrosis del mismo. Todo lo anterior dependiendo de la cantidad de veneno inoculado.

En cuanto al manejo, en primer lugar, se inicia el tratamiento analgésico, requiriéndose en gran parte de los mismos opioides para el control del dolor. A continuación, en todos estos casos se emplearon antibióticos de amplio espectro a pesar de la carencia de evidencia de la vectorización bacteriana a través de los arácnidos⁵. En el 75% de los casos se administraron corticoides con disparidad en cuanto a dosis y vía de administración. En cuanto a la curas, se recomienda limpieza de la misma con jabón y agua templada, así como aplicación de compresas frías para intentar disminuir la inflamación. Vacunación antitetánica si estuviera indicada.

Además de lo anterior, en la literatura encontramos un amplio abanico de posibilidades terapéuticas sin una evidencia que le respalde⁶⁻⁷, entre los que encontramos:

- Vasodilatadores
- Empleo de heparina
- Nitroglicerina
- Cámara de oxígeno hiperbárico, que dispone de ligera evidencia
- Electroshock
- Antihistamínicos
- Corticoesteroides

Estos dos últimos se han empleado con seguridad, y se ha observado una discreta efectividad en cuanto al control sintomatológico, sin haber retrasado la evolución ni acelerado el proceso de curación.

En cuanto a los tratamientos que se han demostrado inefectivos encontramos:

- La Dapsona, a que evitar dado el sustancial riesgo al desarrollo de anemia aplásica y metahemoglobinemia en estos pacientes.
- La inyección intralesional de CE
- La excisión de las lesiones dado el riesgo de extensión de la demonecrosis.

Dado lo anterior, podemos concluir que no exista un tratamiento óptimo ni siquiera generalmente aceptado.

En cuanto al tratamiento quirúrgico, se ha de evitar la excisión temprana o el curetaje de las lesiones necróticas en desarrollo, dado que pueden conllevar un empeoramiento y una limitación funcional del lugar afecto. Sin embargo, una vez la lesión se encuentra demarcada y estable desde el punto de vista clínico, el desbridamiento y las curas de las lesiones pueden conseguir una mejor cicatrización.

Se ha descrito en una muestra de ocho pacientes el empleo de la VAC, es decir, el empleo del cierre de heridas asistido por vacío podría mejorar la cura de estas lesiones necróticas.

En cuanto al pronóstico, sólo se han descrito dos eventos fatales por dicha picadura, un recientemente en Italia en el 2016 y otro en Tailandia. Ambos probables casos, sin haberse demostrado fidedignamente la etiología.

Juicio clínico

Loxocelismo cutáneo necrótico grave por *Loxosceles rufescens*

Conflicto de intereses

Ninguno.

Bibliografía

1. Vadell M. Fauna invertebrada de las cavidades del barranc de Sa Coma del Mal Pas. *Endins* 2003; 25:107-16.
2. Planas E et al. Ecological niche and phylogeography elucidate complex biogeographic patterns in *Loxosceles rufescens* (Araneae, Sicariidae) in the Mediterranean Basin. *BMC Evol Biol.* 2014 Oct 9; 14:195
3. Morales-Moreno HJ et al. Cutaneous loxoscelism due to *Loxosceles rufescens*. *J Eur Acad Dermatol Venereol.* 2016 Aug;30(8):1431-2.
4. Planas E et al. Not as docile as it looks? *Loxosceles* venom variation and loxoscelism in the Mediterranean Basin and the Canary Islands. *Toxicon* 2015; 93: 11-9.
5. Ribuffo D et al. Upper eyelid necrosis and reconstruction after spider bite: case report and review of the literature. *Eur Rev Med Pharmacol Sci* 2012; 16: 414-7.
6. Bajin MS et al. Necrotic arachnidism of the eyelid due to *Loxosceles rufescens* spider bite. *Cutan Ocul Toxicol* 2011; 30: 302-5.
7. Borkan J et al. An outbreak of venomous spiderbites in a citrus grove. *Am J Trop Med Hyg* 1995; 52: 228-30.



www.ramib.org

Junta Directiva de la Reial Acadèmia de Medicina de les Illes Balears

President Excm. Sr. Joan Besalduch Vidal
Vicepresident Àngel Arturo López González
Secretari General Javier Cortés Bordoy
Vicesecretari Sebastian Crespí Rotger
Tresorer Joan Benejam Gual
Bibliotecària Antonia Barceló Bennassar

Acadèmics d'honor

2007 - Excm. Sr. Ciril Rozman, Premi Jaime I
2021 - Excm. Sr. Oriol Bonnín Gubianas, Doctor Honoris Causa per la UIB

Acadèmics numeraris

M. I. Sra. Juana M. Román Piñana
M. I. Sr. Josep Tomàs Monserrat
M. I. Sr. Bartomeu Anguera Sansó
M. I. Sr. Alfonso Ballesteros Fernández
M. I. Sr. Ferran Tolosa i Cabaní
M. I. Sr. Macià Tomàs Salvà
M. I. Sra. Joana M. Sureda Trujillo
M. I. Sr. Joan Buades Reinés
M. I. Sr. José L. Olea Vallejo
M. I. Sr. Pere Riutord Sbert
Excm. Sr. Joan Besalduch Vidal
M. I. Sr. Fèlix Grases Freixedas
M. I. Sr. Antoni Cañellas Trobat
M. I. Sr. Josep Francesc Forteza Albertí
M. I. Sr. Jordi Ibáñez Juvé
M. I. Sr. Joan March Noguera
M. I. Sr. Àngel Arturo López González
M. I. Sra. Pilar Roca Salom
M. I. Sr. Javier Cortés Bordoy
M. I. Sr. Lluís Masmiquel Comas
M. I. Sr. Sebastià Crespí Rotger
M. I. Sra. Antònia Barceló Bennassar
M. I. Sr. Javier Garau Alemany
M. I. Sr. Jordi Reina Prieto
M. I. Sr. Joan M. Benejam Gual
M. I. Sr. Claudio Rubén Mirasso Santos
M. I. Sr. Josep M^a Vicens Gómez
M. I. Sr. Rafael Morales Soriano

Acadèmics supernumeraris

M.I. Sr. Àlvar Agustí García-Navarro
M.I. Sra. Marta Emma Couce Matovelle

Acadèmics emèrits

M.I. Sr. Arnau Casellas Bernat



www.ramib.org

Protectors de la Reial Acadèmia

Banca March
Conselleria de Presidència
ASISA
Conselleria de Salut
Col·legi Oficial de Metges de les Illes Balears
Fundació Patronat Científic del Col·legi de Metges de les Illes Balears

Benefactors de la Reial Acadèmia

Salut i Força

Patrocinadors de la Reial Acadèmia

Clínica Rotger
Metges Rosselló
Grup Hospitalari Quirónsalud
Col·legi Oficial d'Infermeria de les Illes Balears
Associació Espanyola contra el Càncer a les Illes Balears
Col·legi Oficial de Farmacèutics de Balears
Escola Universitària ADEMA

ACADEMIC JOURNAL
OF HEALTH SCIENCES

MEDICINA BALEAR

www.medicinabaleaer.org